

Development of Cryogen-free Conduction-Cooled 5-Tesla Wavelength Shifter Utilizing HTS Technology

19. June. 2025, AFAD2025

Garam Hahn (Pohang Accelerator Laboratory/POSTECH)

Jeonghwan Park & Seungyong Hahn (Seoul National University)



- Pohang Accelerator Laboratory

- PLS2 - 3 GeV, 400 mA, 3rd Gen. Storage ring
- PAL-XFEL - 10 GeV, XFEL

- Korea-4GSR Project

- 4 GeV, 400 mA, 4th Gen. Storage ring (~2029)

- Both of facilities use warm permanent magnet based ID



Korea-4GSR



PLS II
(Pohang Light Source)

- (2020) HTS-U Proto. → (2022-) HTS-3PW5T → (2025-) HTS-MPW 4T-3λ → (2026?-) HTS-MPW 4T-30λ → (2027?-) HTS-U

- Purpose : To develop an ID technology for future light sources

- Warm iron dominated accelerator magnet → Permanent magnet ID → Cryogenic PMU || LTS wiggler || HTS wiggler

- R&D Target : HTS-3PW

- Magnetic field strength > 5 tesla = making higher energy photon > 100 keV
- LHe-free cryogenic system by adopting a conduction cooling Tech. for saving operational cost
- Enabling the above by using ReBCO conductor + NI technology
Operation temperature ~ 20 K
Maximize reliability (almost quench free)

- Current Status

- Dedicated cryostat and beam pipe were assembled with the HTS magnet core
- 30 days non-stop operation experiment & field measurement

Cryogen-free Conduction-cooled REBCO Undulator (2020-2021)

$$\lambda = 14 \text{ mm}, n(\lambda) = 1.5, B_0 = 0.8 \text{ T}$$

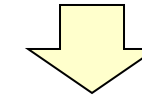

Cryogen-free Conduction-cooled REBCO Wavelength Shifter (2022 -)

$$L_{magnet} = 0.42 \text{ m}, B_0 > 5 \text{ T}$$

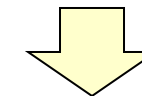

Cryogen-free Conduction Cooled REBCO Multipole Wiggler (2022 - 2026)

$$\lambda = 60 \text{ mm}, n(\lambda) > 5, B_0 > 4 \text{ T}$$

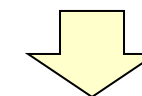

HTS-MPW 4T-30λ

HTS-U

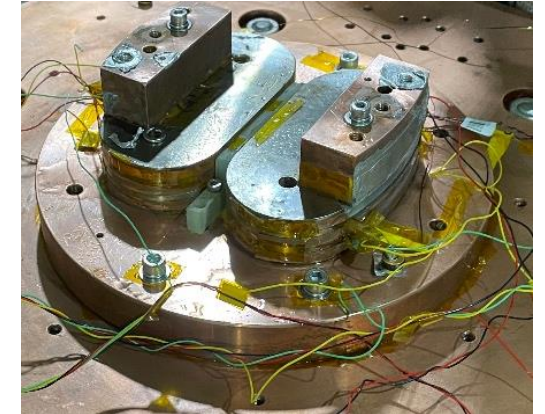

■ (2020) HTS-U Proto. → (2022-) HTS-3PW 5 T → (2025-) HTS-MPW 4T-3λ → (2026?-) HTS-MPW 4T-30λ → (2027?-) HTS-U

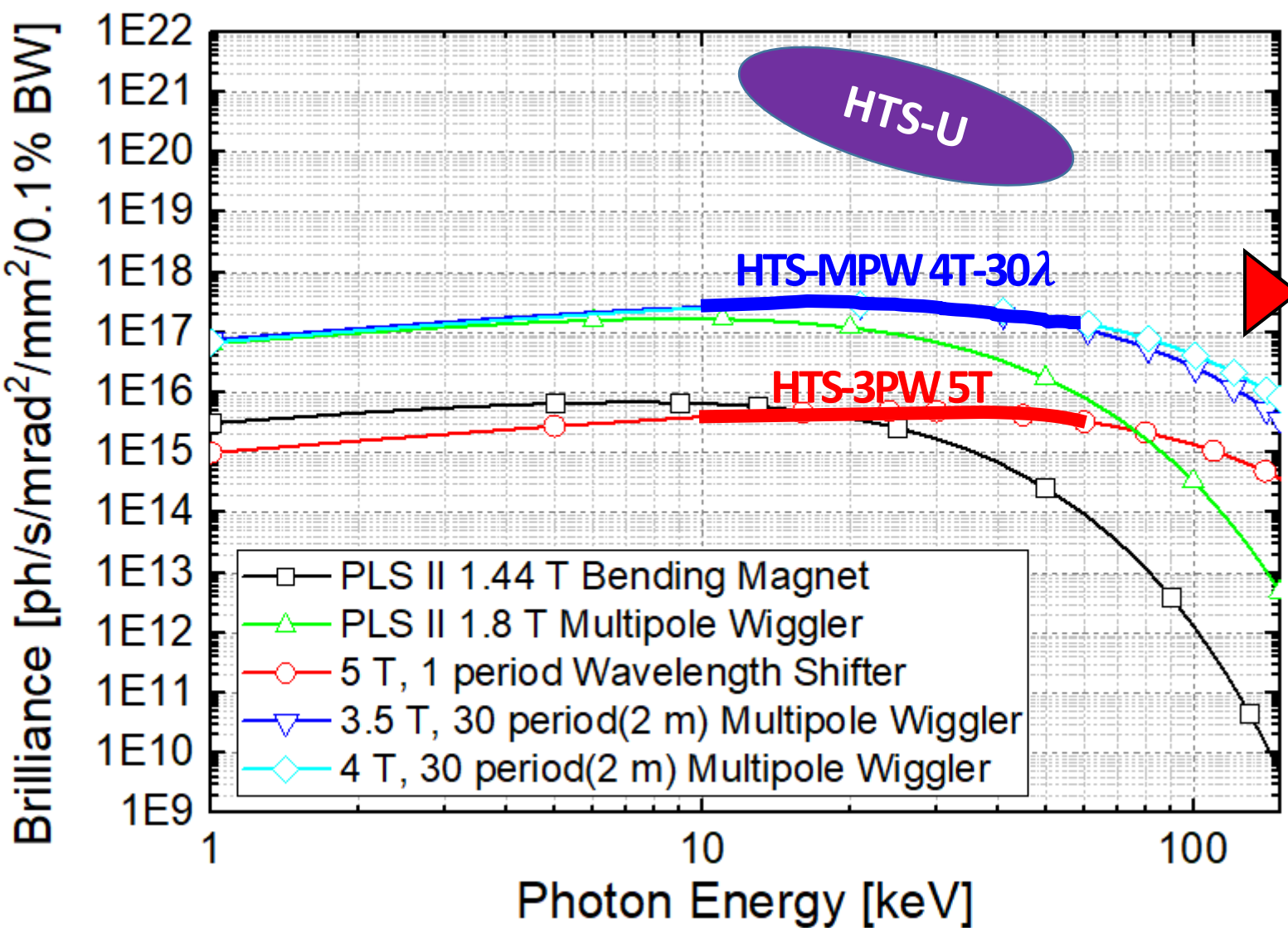

Cryogen-free Conduction-cooled REBCO Undulator (2020-2021)

$$\lambda = 14 \text{ mm}, n(\lambda) = 1.5, B_0 = 0.8 \text{ T}$$

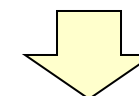

Cryogen-free Conduction-cooled REBCO Wavelength Shifter (2022 -)

$$L_{magnet} = 0.42 \text{ m}, B_0 > 5 \text{ T}$$

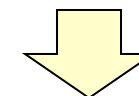

Cryogen-free Conduction Cooled REBCO Multipole Wiggler (2022 - 2026)

$$\lambda = 60 \text{ mm}, n(\lambda) > 5, B_0 > 4 \text{ T}$$

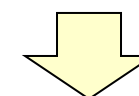

HTS-MPW 4T-30λ

HTS-U

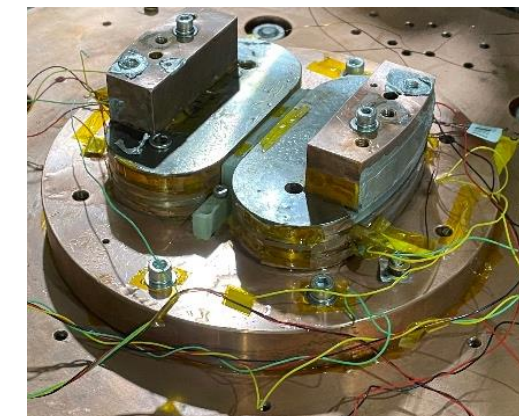

- Current status of HTS ID development of the leading groups
 - Various research is conducted by KIT, ANL, CAS, PSI, and CERN (Col. with KIT) by using LTS & HTS technology
 - Regarding HTS, a few attempts have been reported but R&D for production is mostly concentrated to LTS + LHe.

Karlsruher Institut of Technology, Germany

Argonne National University, USA

Chines Academy of Sciences, China

CERN, Karlsruher Institut of Technology, Europe

Paul Scherrer Institute

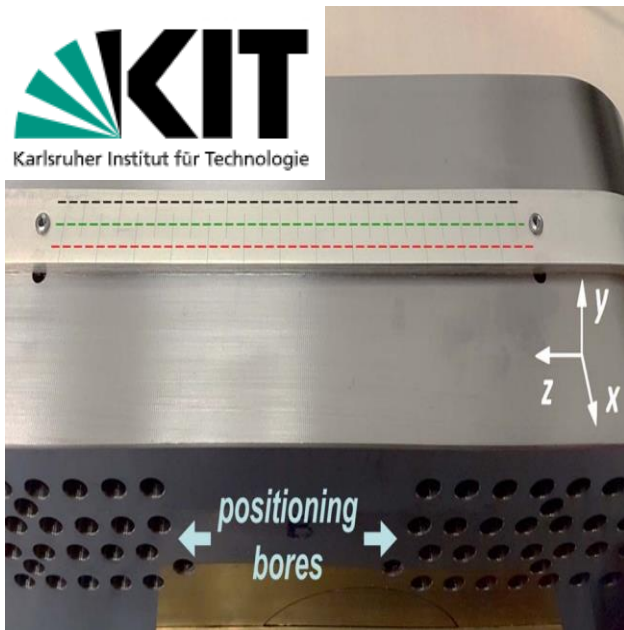

T Holubek *et al.*, "A novel concept of high temperature superconductor undulator," *Supercond. Sci. Technol.*, vol 30, no.11, 115002 (2017)

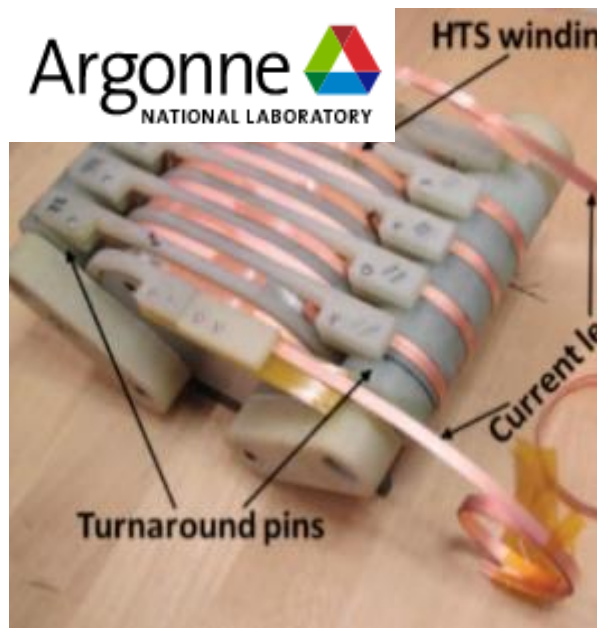

Y. Ivanyushenkov and *et al.*, "Status of the Development of Superconducting Undulators at the Advanced Photon Source," *Synchrotron Radiation News*, (2018)

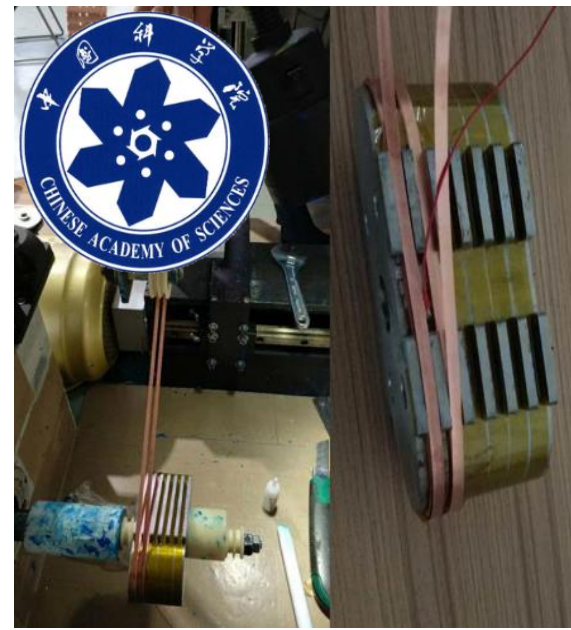

Schichang Liu *et al.*, "Development of a Short REBCO Undulator Magnet With Resistive Joints," vol 29, no. 6, 4100204, *IEEE. Trans. Appl. Supercond.* (2019)

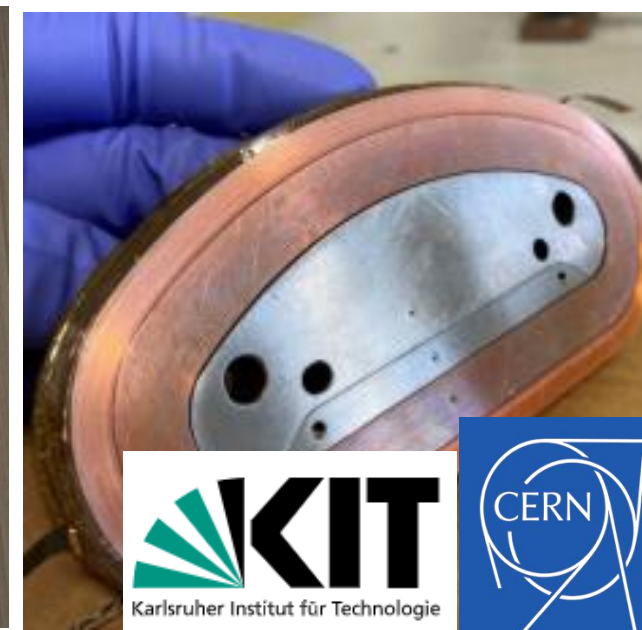

S.C. Richter *et al.*, "Progress on HTS undulator prototype coils for compact FEL designs," vol 32, no. 4, 4100305, *IEEE. Trans. Appl. Supercond.* (2022)

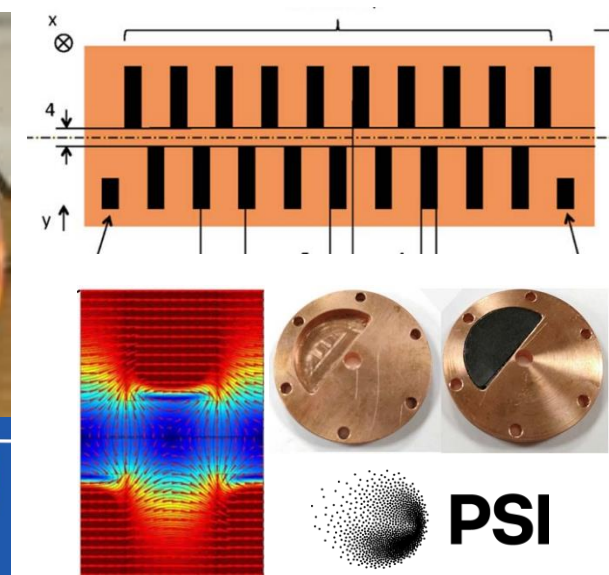

M Calvi *et al.*, "A GdBCO bulk staggered array undulator" vol 33, 014004, *Supercond. Sci. Technol.* (2020)

■ HTS Wavelength Shifter

□ Key Design Concepts: (1) multi-width; (2) conduction cooling; (3) metal insulation

- Multi-width: combination of 4 mm and 5 mm width REBCO conductor
- Conduction cooling: **critical current margin of >20%** considering conduction cooling operation

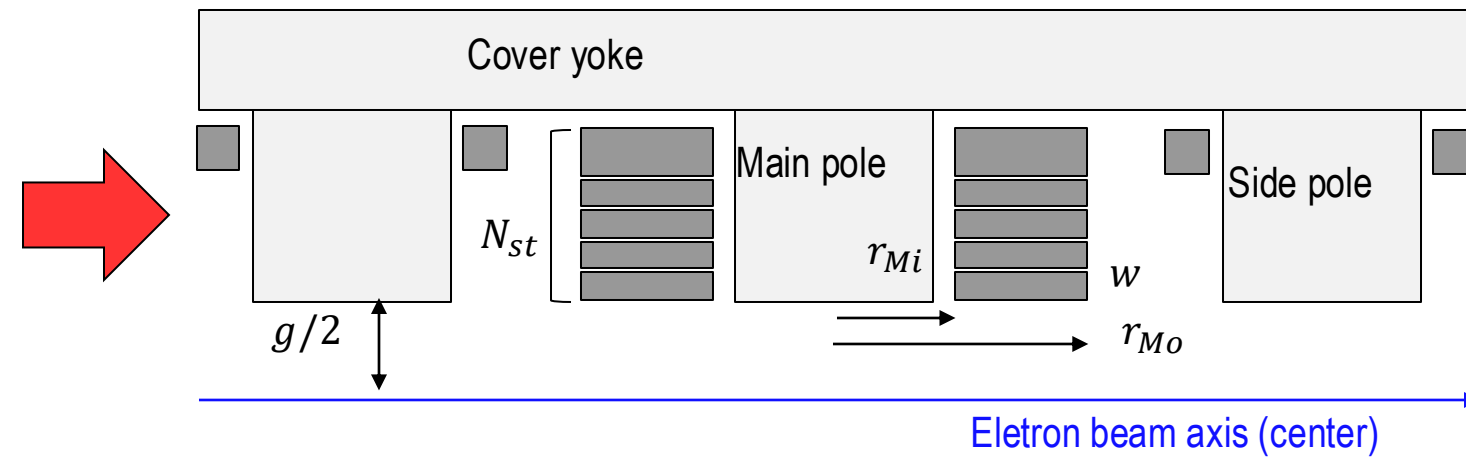
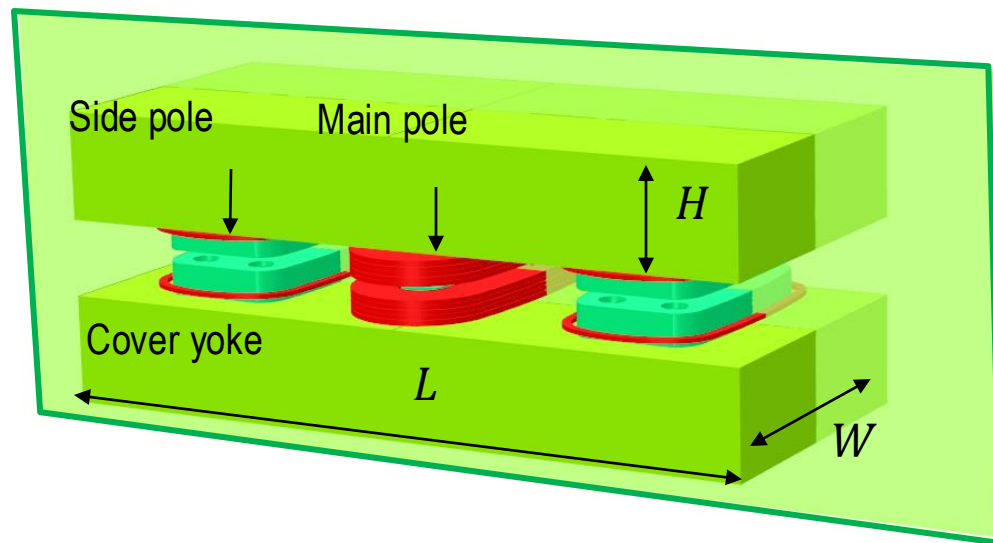

Max. $F(x) = (f_1(x), f_2(x))$

$f_1(x) = B_M; f_2(x) = l_{REBCO}; x = (N_{stack}, N_M, H)$

Swept Parameters			
	Min	Max	Interval
N_{stack}	4	10	1
N_M [turns]	100	300	25
H [mm]	50	150	50

g : magnetic gap (=12 mm) N_M : Number of mainpole turns H : Yoke thickness
 L : Yoke length (=670mm) W : Yoke width (=300 mm) N_{st} : number of stacks
 r_{Mi} : Inner radius of mainpole t_{cd} : conductor thickness (=0.2 mm)
 r_{Mo} : Outer radius of mainpole ($=r_{Mi} + t_{cd}N_M$) w_i : i th stack width (4.1, 5.1 mm)

■ Parameter Sweep Results

- Final design is selected considering HTS conductor in stock (~ 1.8 km) $\sim 43,200$ KRW (24 k KRW/meter)

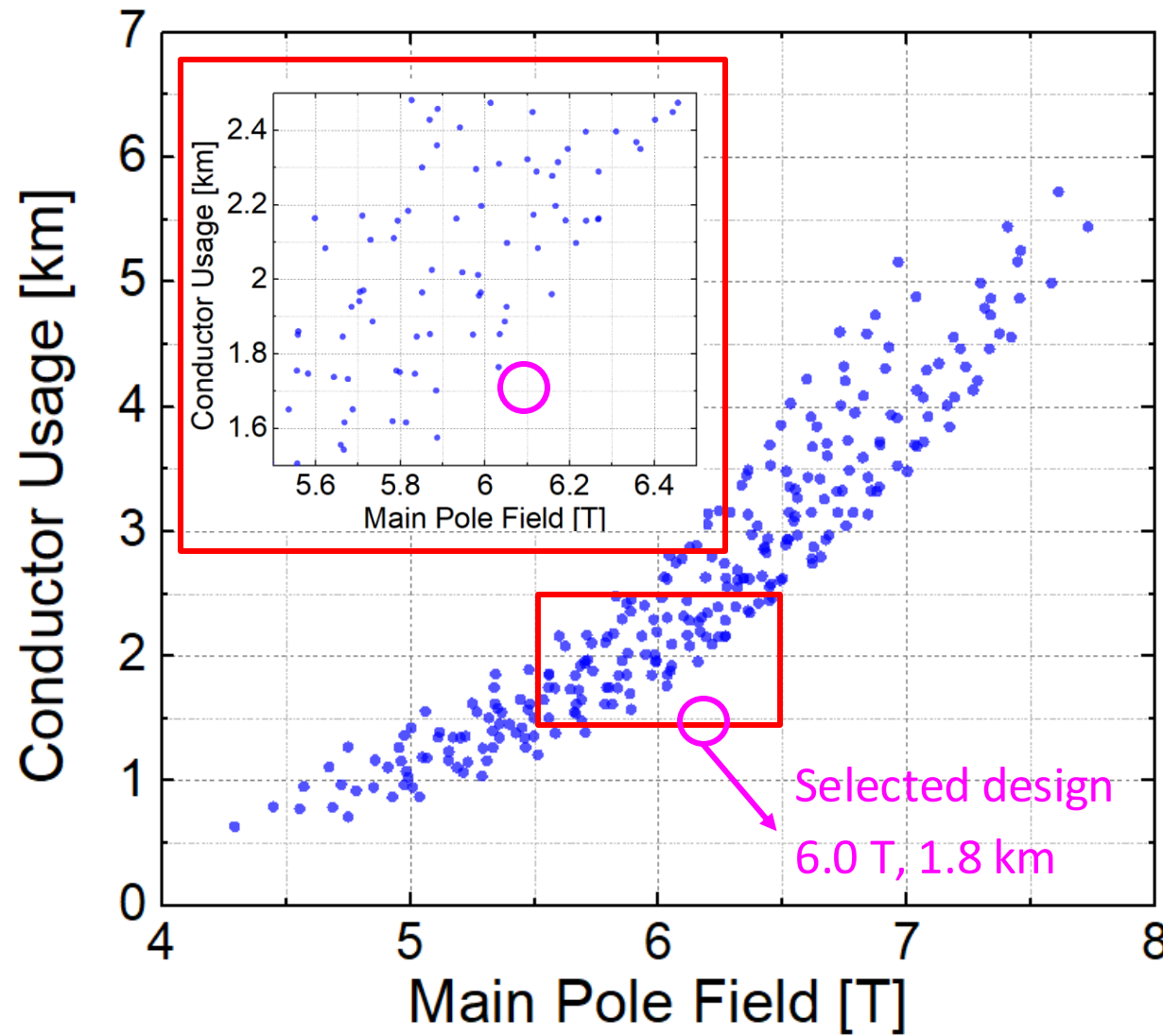

$$(N_{stack}, N_M, H) = (5, 200, 100 \text{ mm})$$

$$l_{REBCO} = 1.8 \text{ km}$$

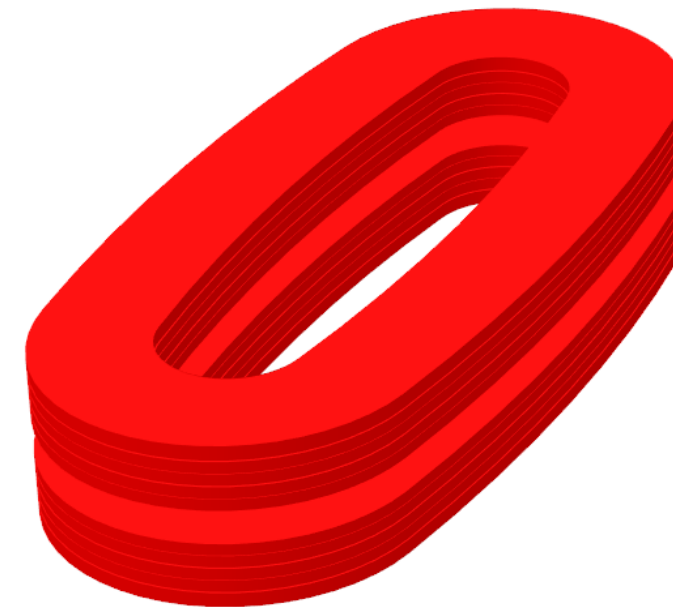

Multi-width combinations of
[4 mm; 4 mm; 4 mm; 4mm; 5 mm]

- Field Uniformity Requirements for Beam Operation
 - (1) zero field integral ($\int B_y dz$); (2) field integral uniformity at $x=15$ mm: <100 G·cm

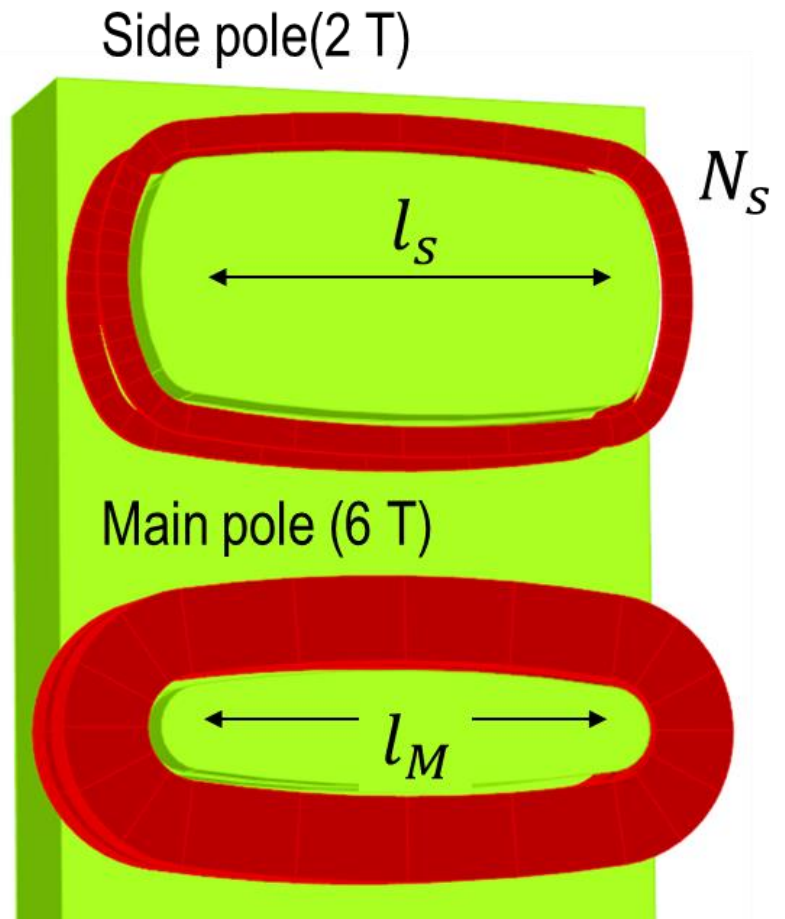

N_S : side pole turns [null]
 l_M : main pole length [mm]
 l_S : side pole length [mm]

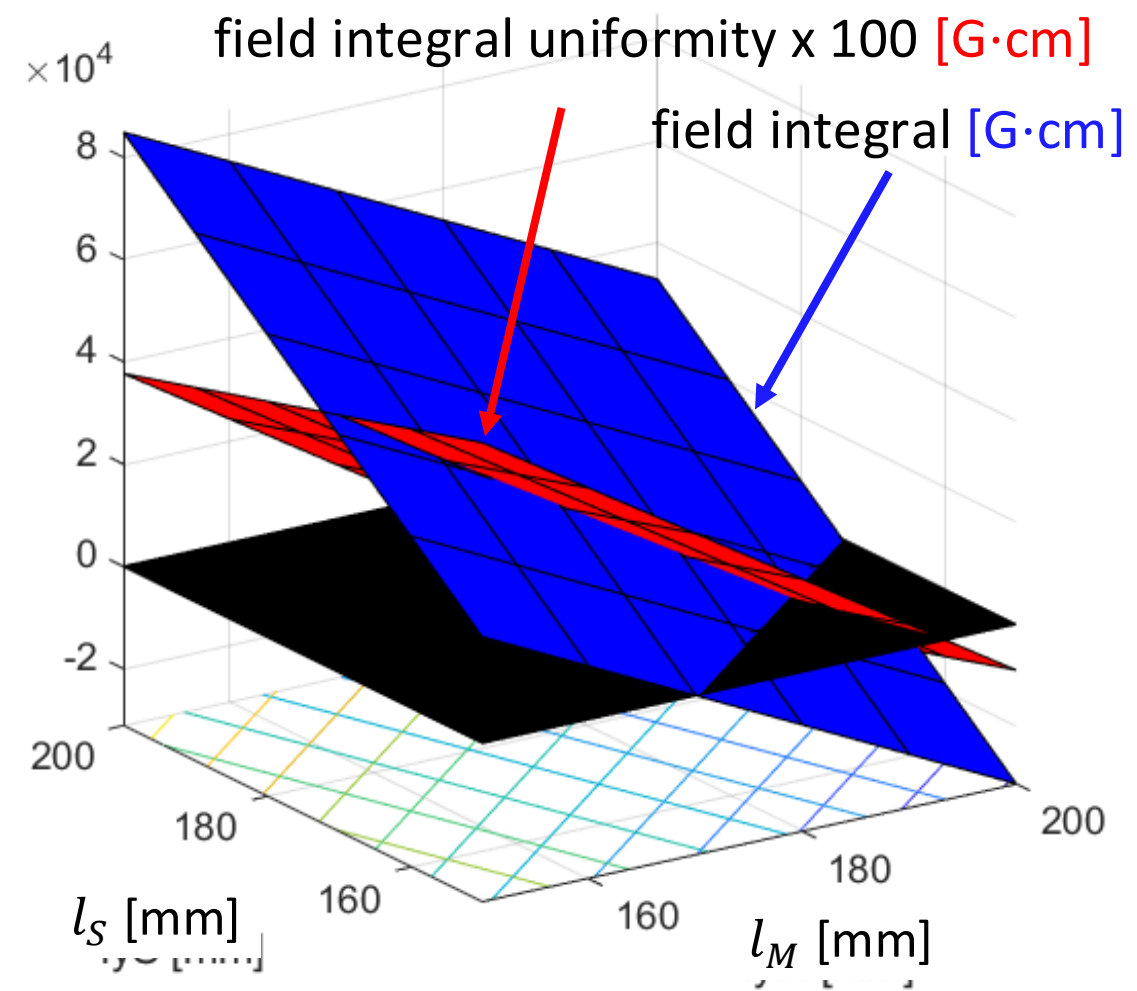

Selected dimension to minimize field integral
 $l_M=188$ mm; $l_S=166$ mm; $N_S=40$

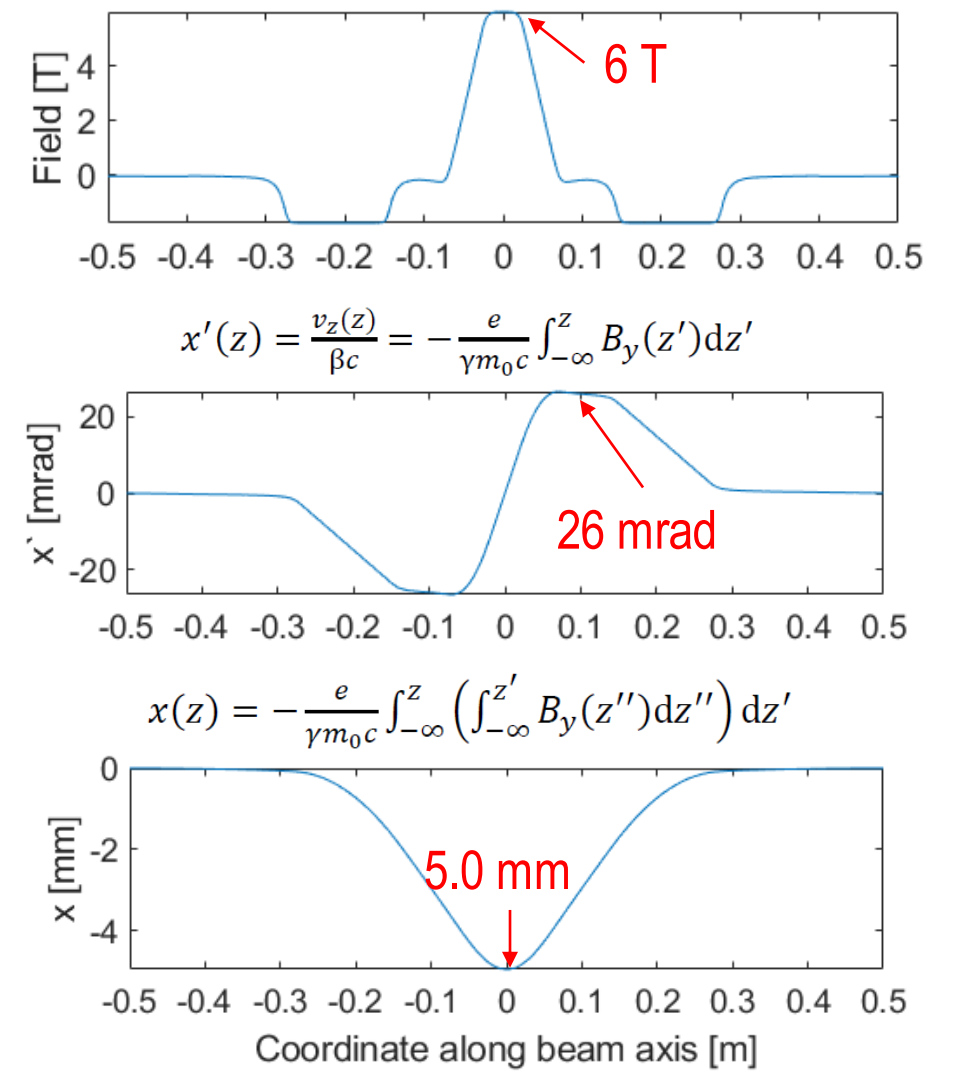

- Stress Analysis of Racetrack Shaped Mainpole Coil[11]
 - Modeling: (1) roller; (2) contact pair; (3) spring foundation
 - Maximum hoop stress of 97 MPa

Governing Equation

Force balance: $\nabla \sigma + \vec{f}_v = 0$

Roller condition: $\vec{u} \cdot \hat{n} = 0$

Spring foundation: $\vec{f} = -ku$

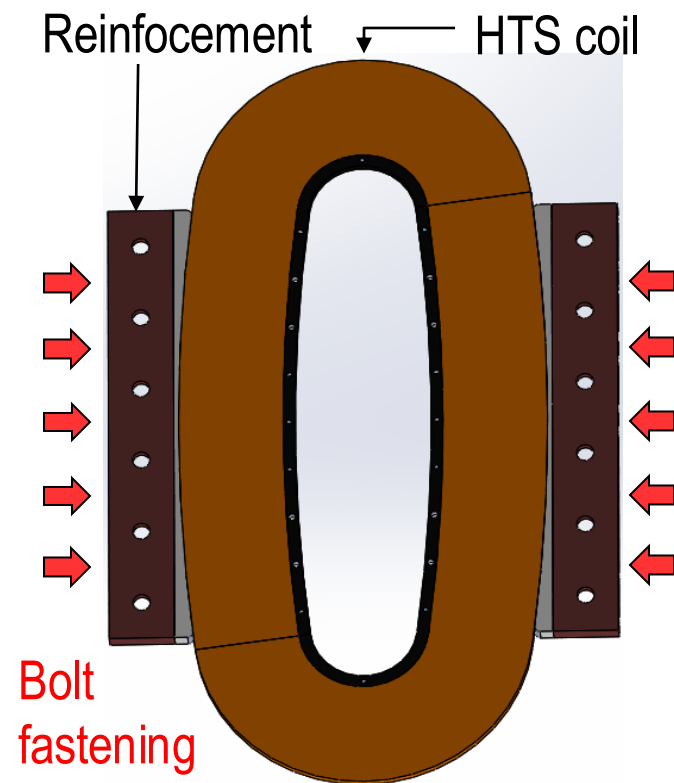

<Racetrack coil structure>

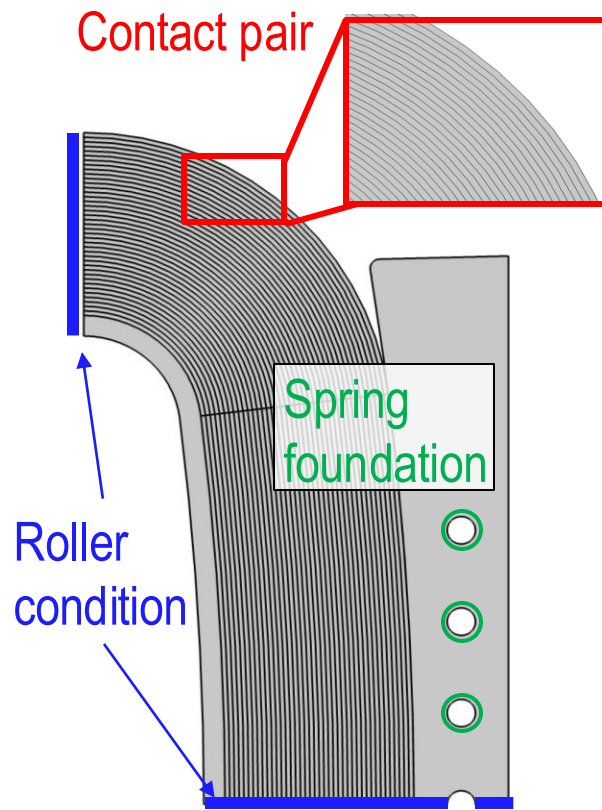

<Modeling>

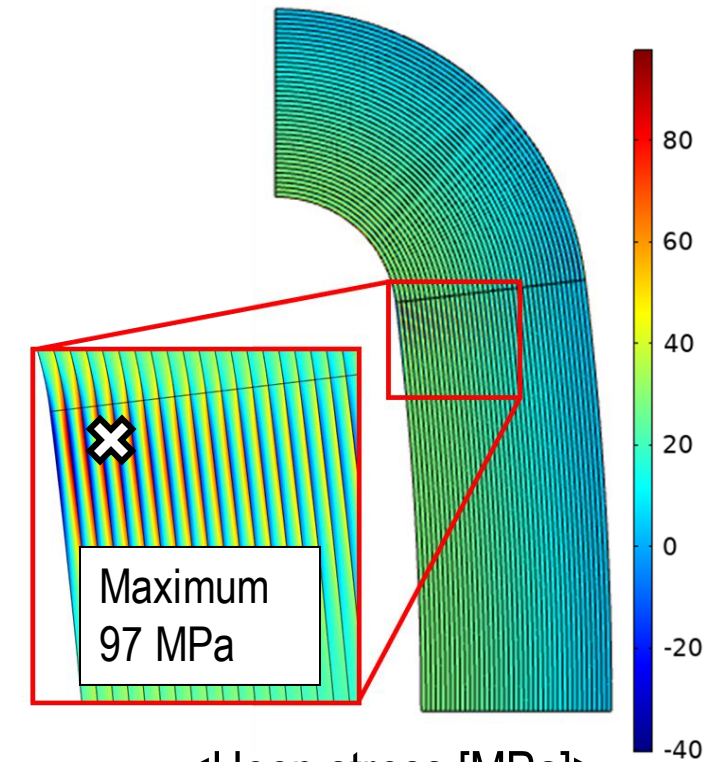

<Hoop stress [MPa]>

U bong *et al.*, "Numerical Studies on mechanical behavior of dry wound HTS racetrack coil," *IEEE. Trans. Appl. Supercond.*, 30.4, 2020

- Heat load and Local Temperature Analysis Results: maximum T of 13 K
 - Heat source: conduction; radiation; resistance; beam induced heat loads
 - Cooling source: cryocooler (PT815)

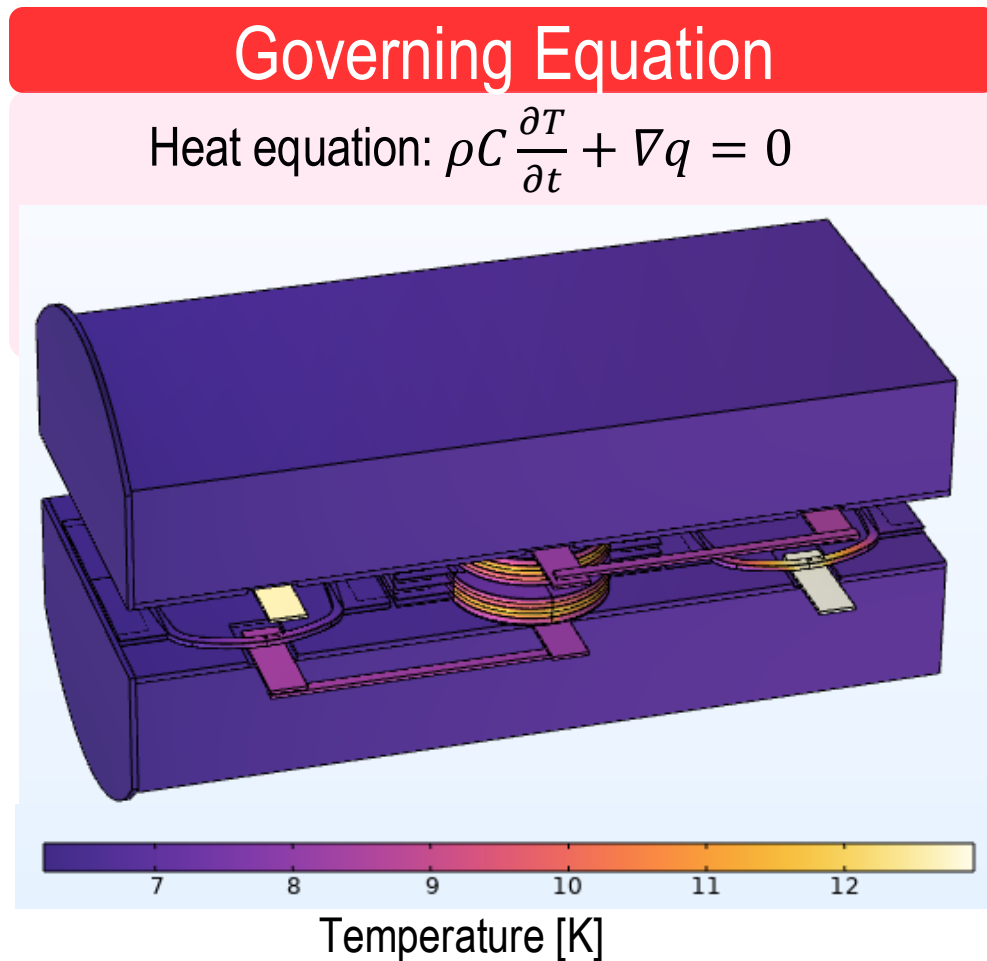

Heat source [W]		2 nd stage	1 st stage
Conduction	Magnet support	<1	<1
	Beamduct support	<0.1	<1
	Beamduct conduction	1.8	9.4
Radiation	Radiation	0.1	16.1
Resistance	Resistive joint	0.16	0
	NI leakage current	<1	0
	Current lead	0.3	33.6
Beam	Image current + Wake impedance	3.3	
	Synchrotron radiation	<1	<1
Total [W]		<10	<65.5
Cooling margin [W]		18	75

■ Key Design parameters

Parameters	Unit	Main pole	Side pole
REBCO tape width	[mm]	4.1; 5.1	
Tape thickness	[um]	140 (REBCO); 60 (SUS)	
Magnetic Gap, g	[mm]	12	
Overall dimension	[mm]	270 x 300 x 670	
Turn per pancake	[Turns]	200	40
Number of Stacks		5	1
Total tape length	[km]	1.8 (4 mm equivalent)	
Magnet Weight	[kg]	360	
Inductance	[H]	5.5-0.7	
Operating current	[A]	173	
Center field at Iop	[T]	6.0	1.8
Temperature, T_{op}	[K]	< 20	

■ Engineering Design Results

- Total of 37 parts

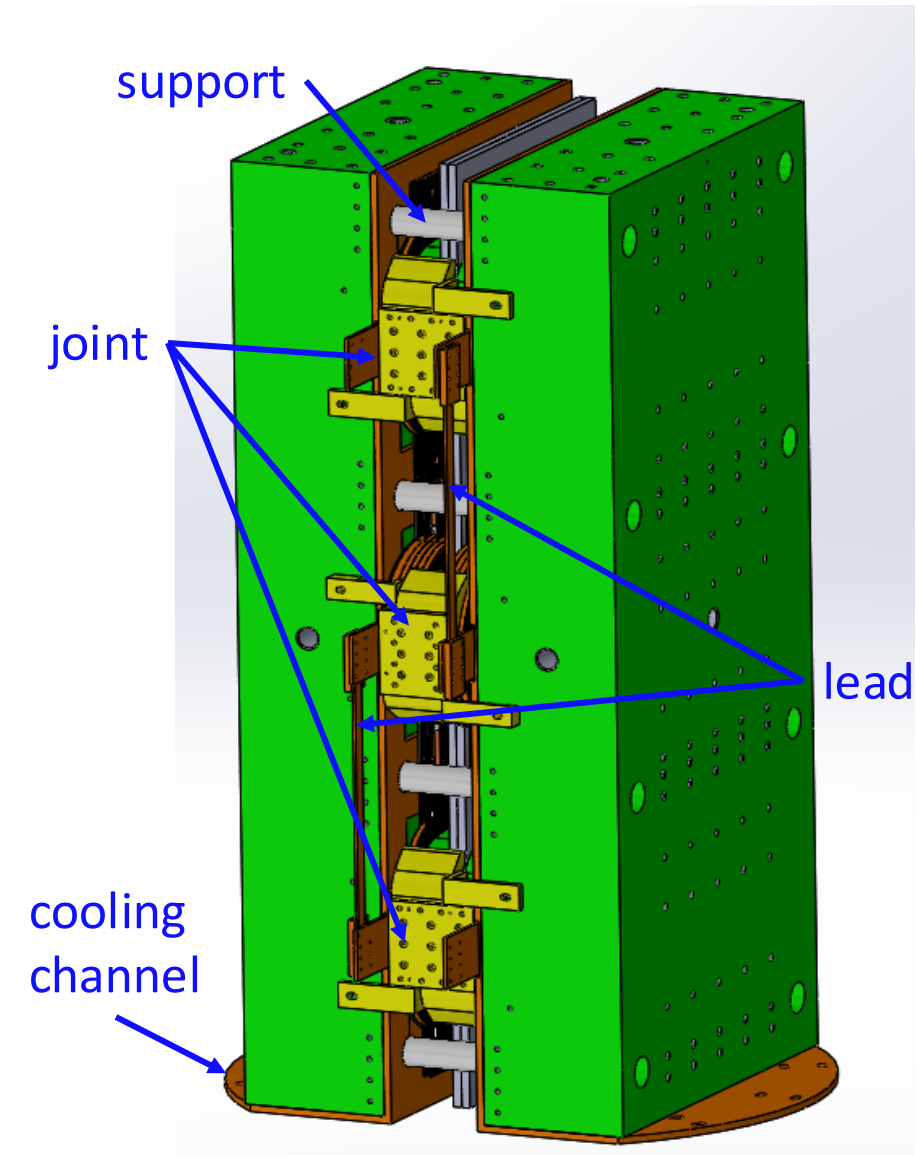

1. Winding



2. LN2 test



3. Cooling channel



4. Stacking



5. Preload

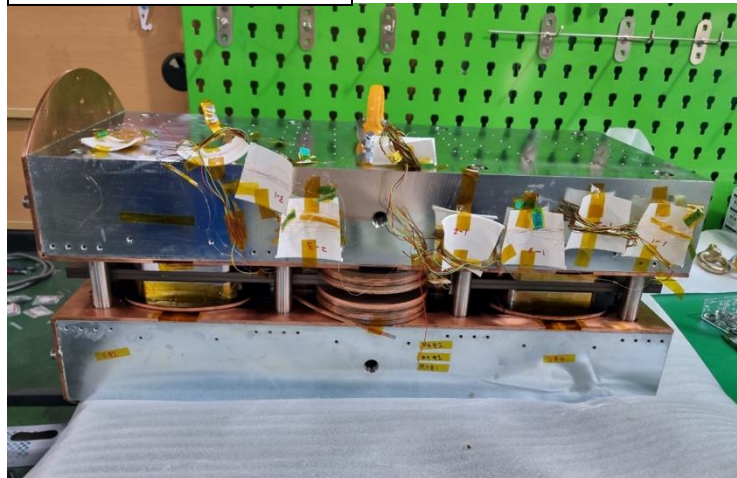

6. Joint & lead



7. Assemble

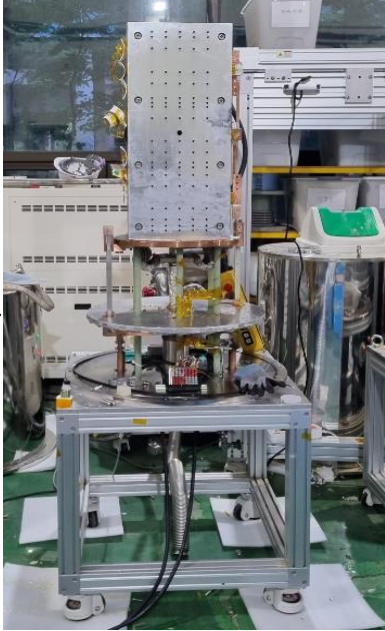

8. Operation



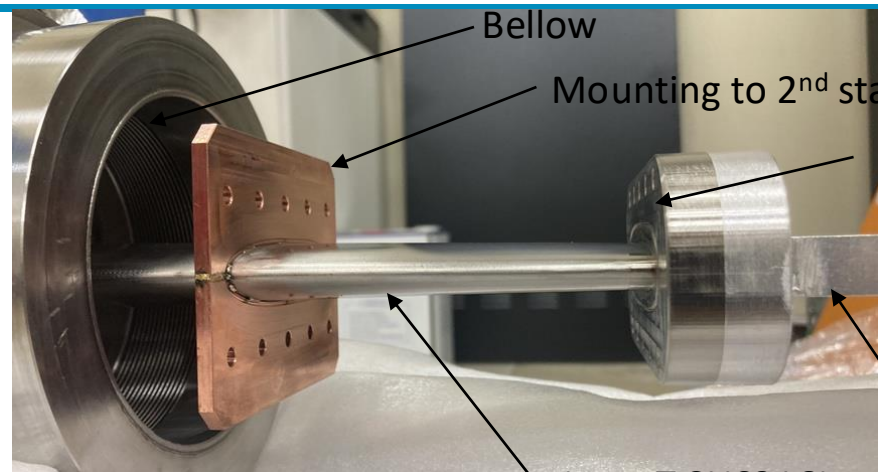
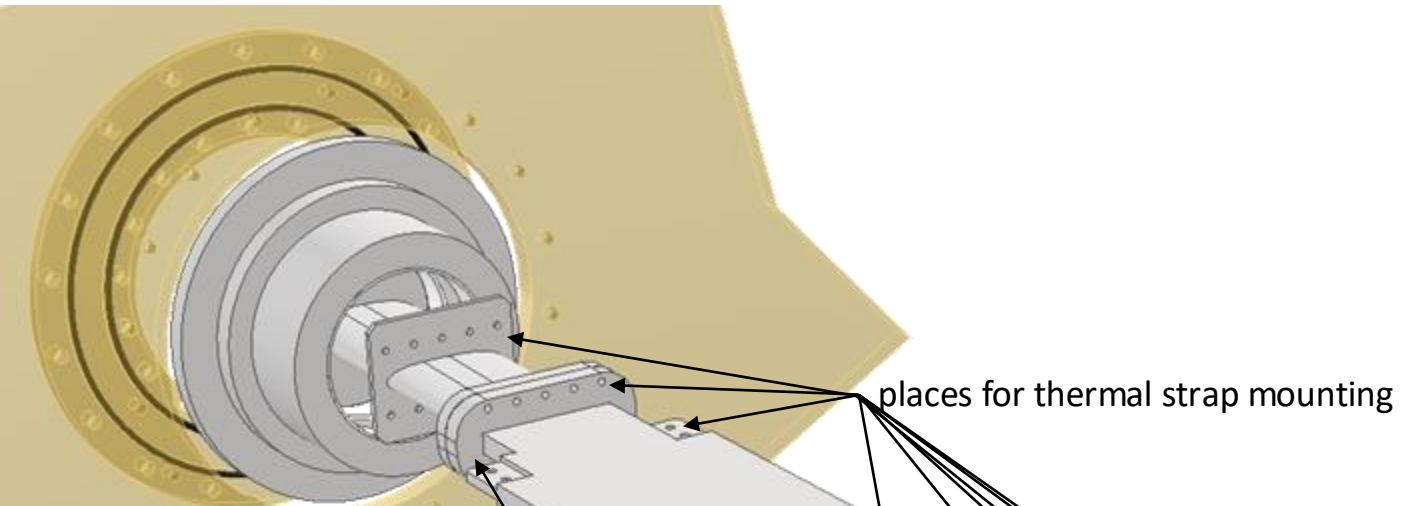

Mechanical deformation check,
AL chamber with thickness of 1 mm

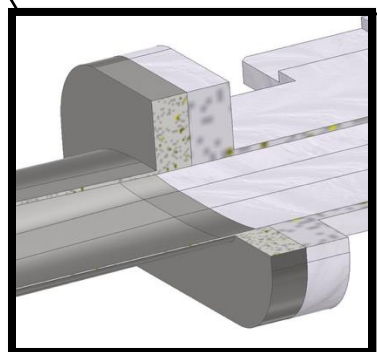
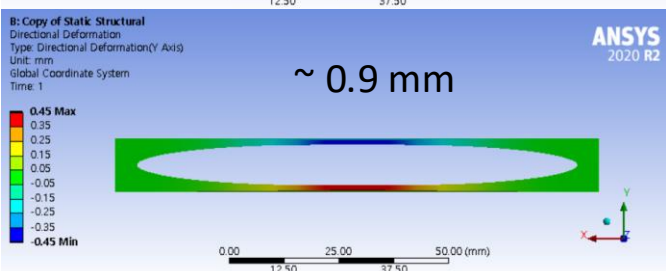
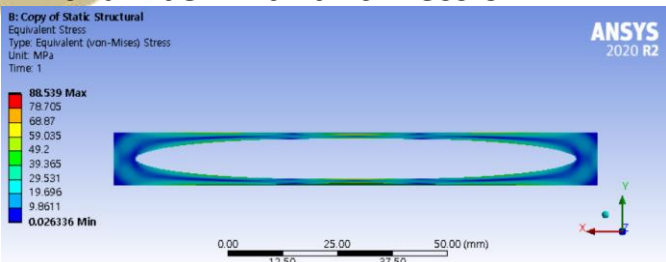

<weldment/HIP: SUS316L-AL5083>

He Leak Rate : 3.0×10^{-9} mbar .l/sec

Op. temperature : 20 k, 60 k

A,B : SUS316L (Thermal transition section),

C : AL5083/AL6061 (Low temperature section),

Wake Impedance (PLS-II, 400 mA operation)

Loss factor : 7.027 mV/pC

P_d per bunch : 12.43 mW

P_d in total : 3.73 W

$$P = - \frac{\text{loss}(V/pC) * (1.33 \text{ nC})^2}{10^{-6} \text{ sec}}$$

<CAD Drawing>

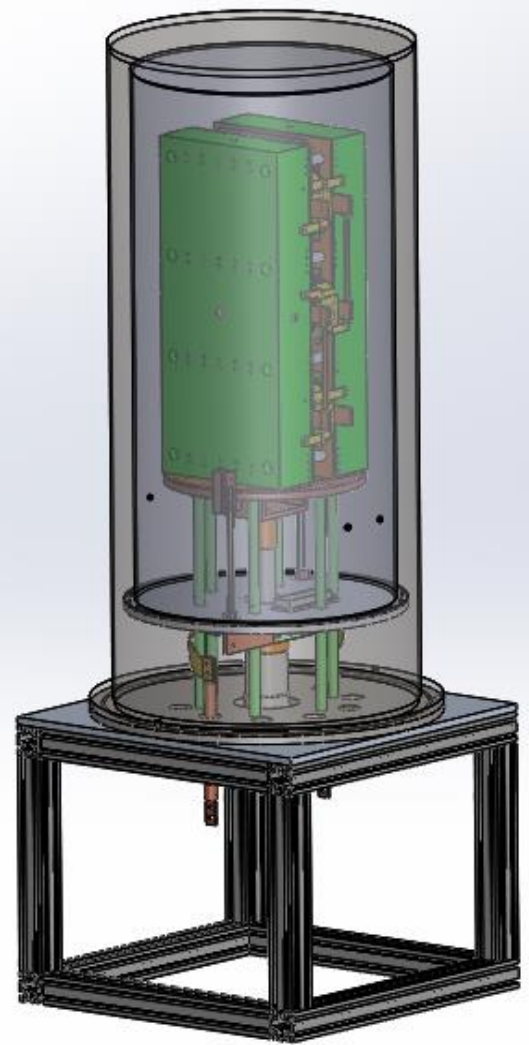

<Assembly picture>

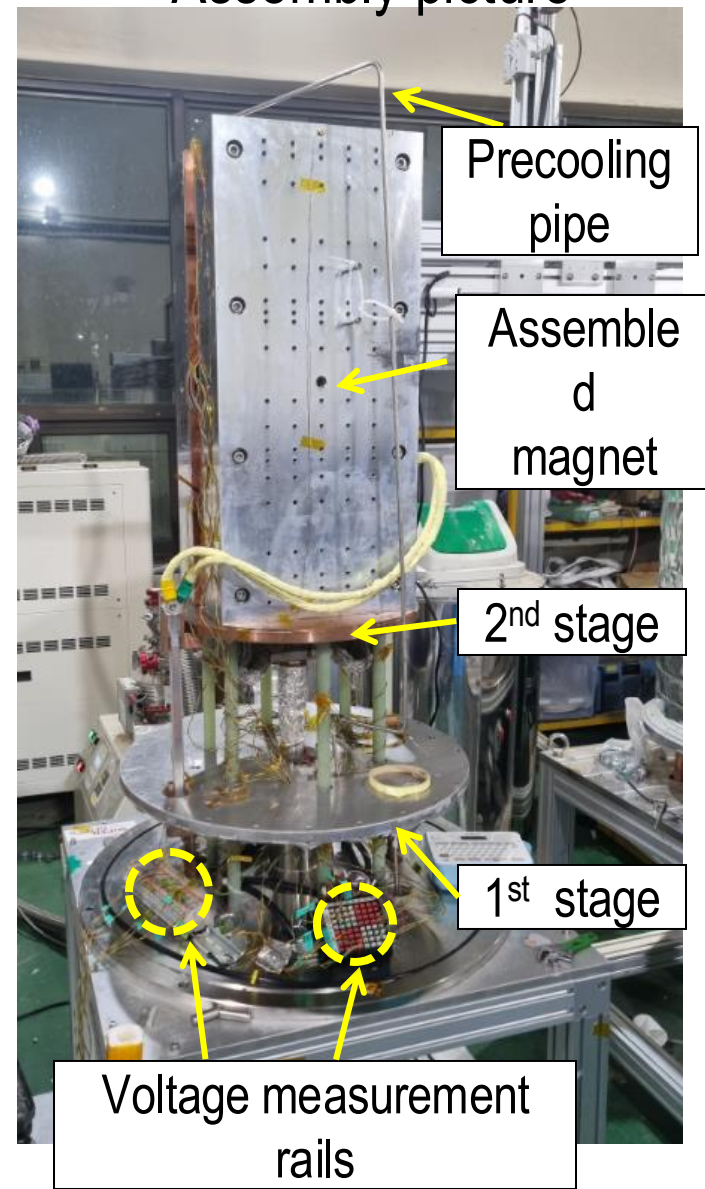

<Measurement system>

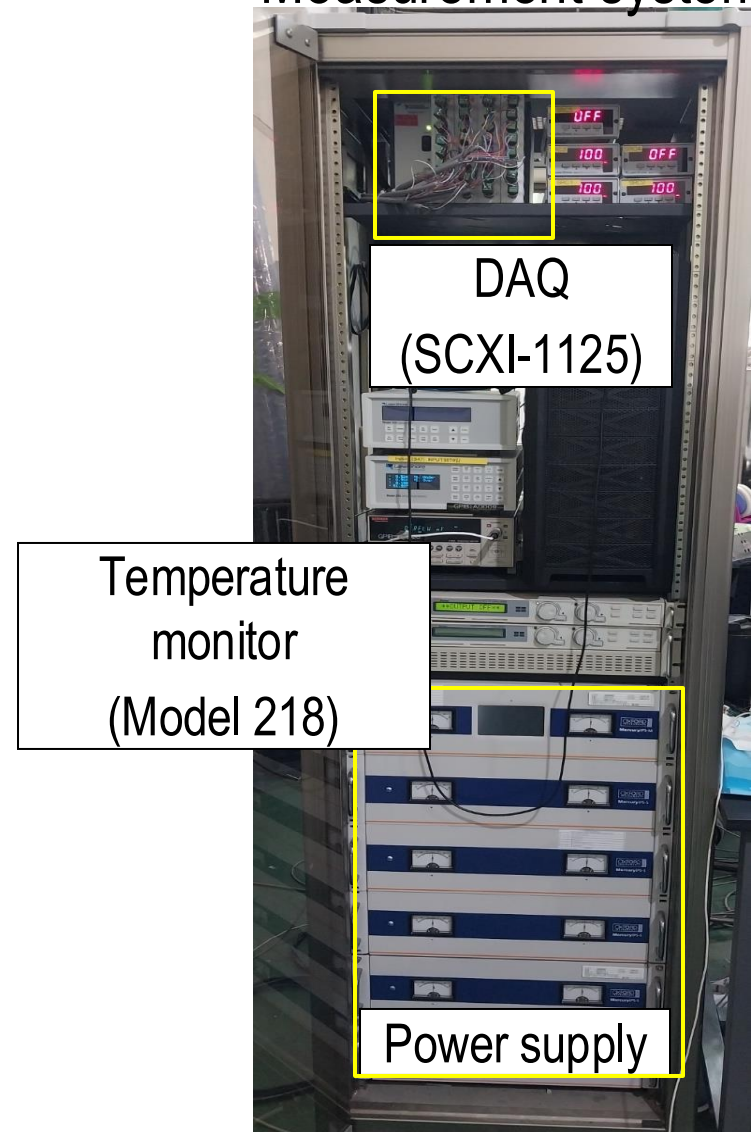

Initial Cooling of Magnet System

- Liquid nitrogen usage: 110 L
 - Dump mode: 97 L; adiabatic mode: 155 L
- Total cooling time: 42 hours

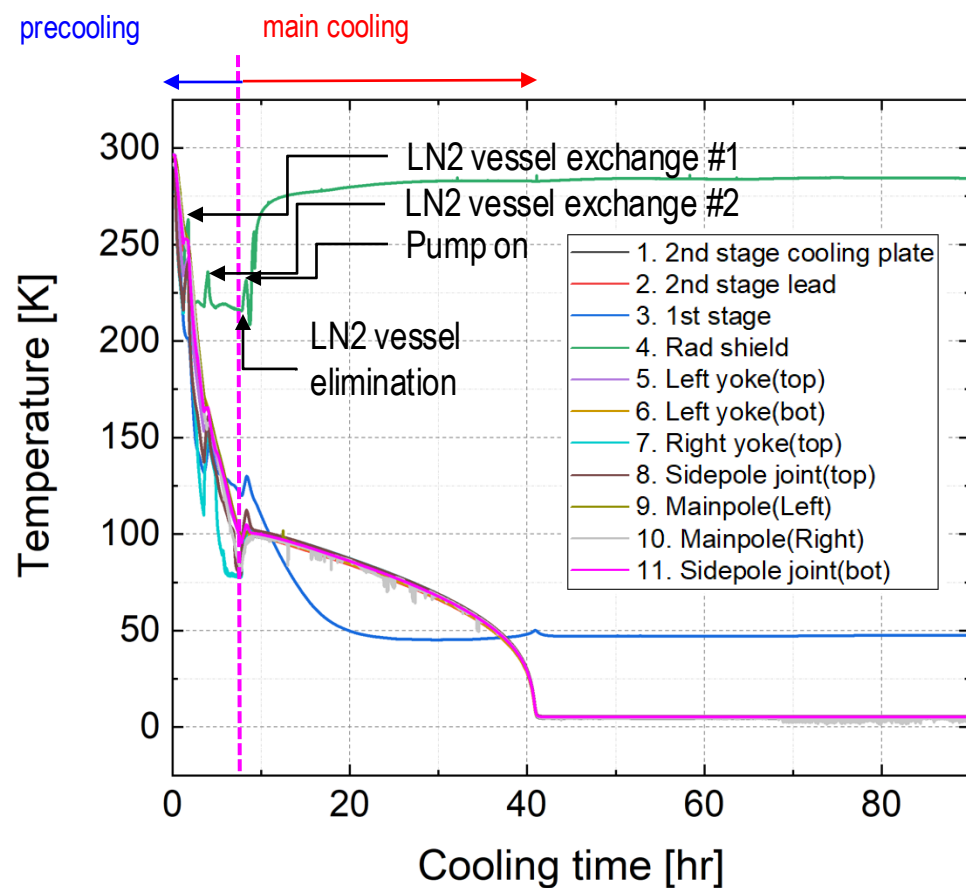

<Temperature sensor locations>

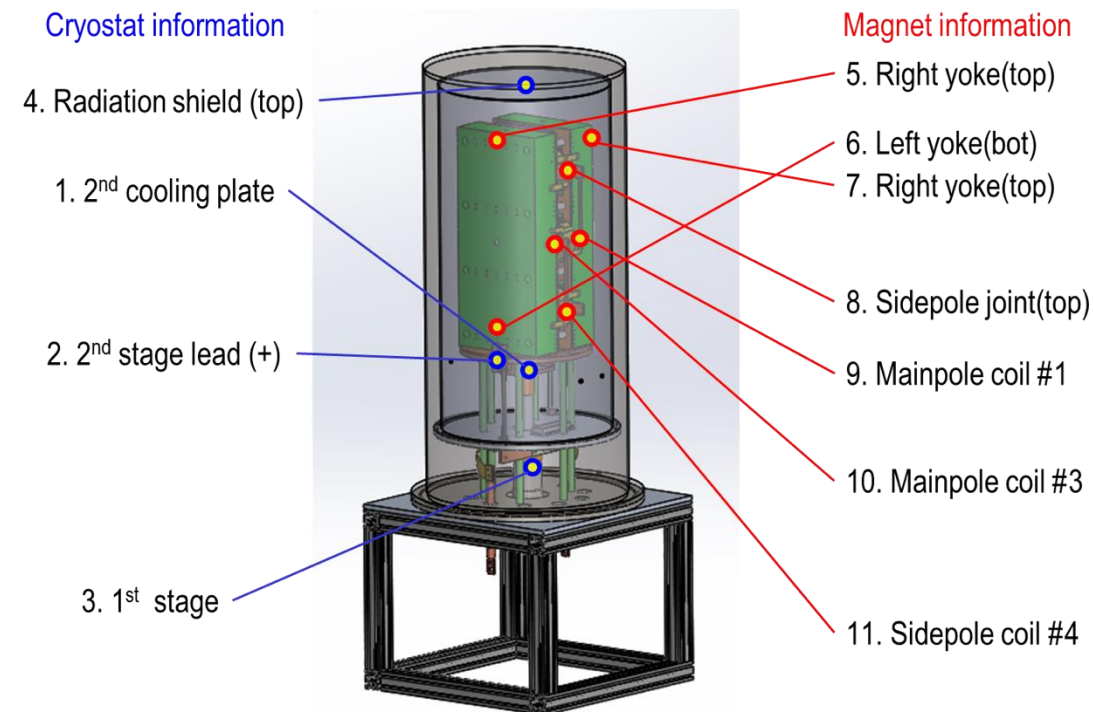

<Final temperature [K]>

#1	#2	#3	#4	#5	#6
4.5	5.4	47.6	284.4	4.6	4.8
#7	#8	#9	#10	#11	
4.9	5.5	5.1	4.6	5.3	

- World First, Coil-type HTS Wavelength Shifter.
- Beam experiment scheduled after a precise field measurement.

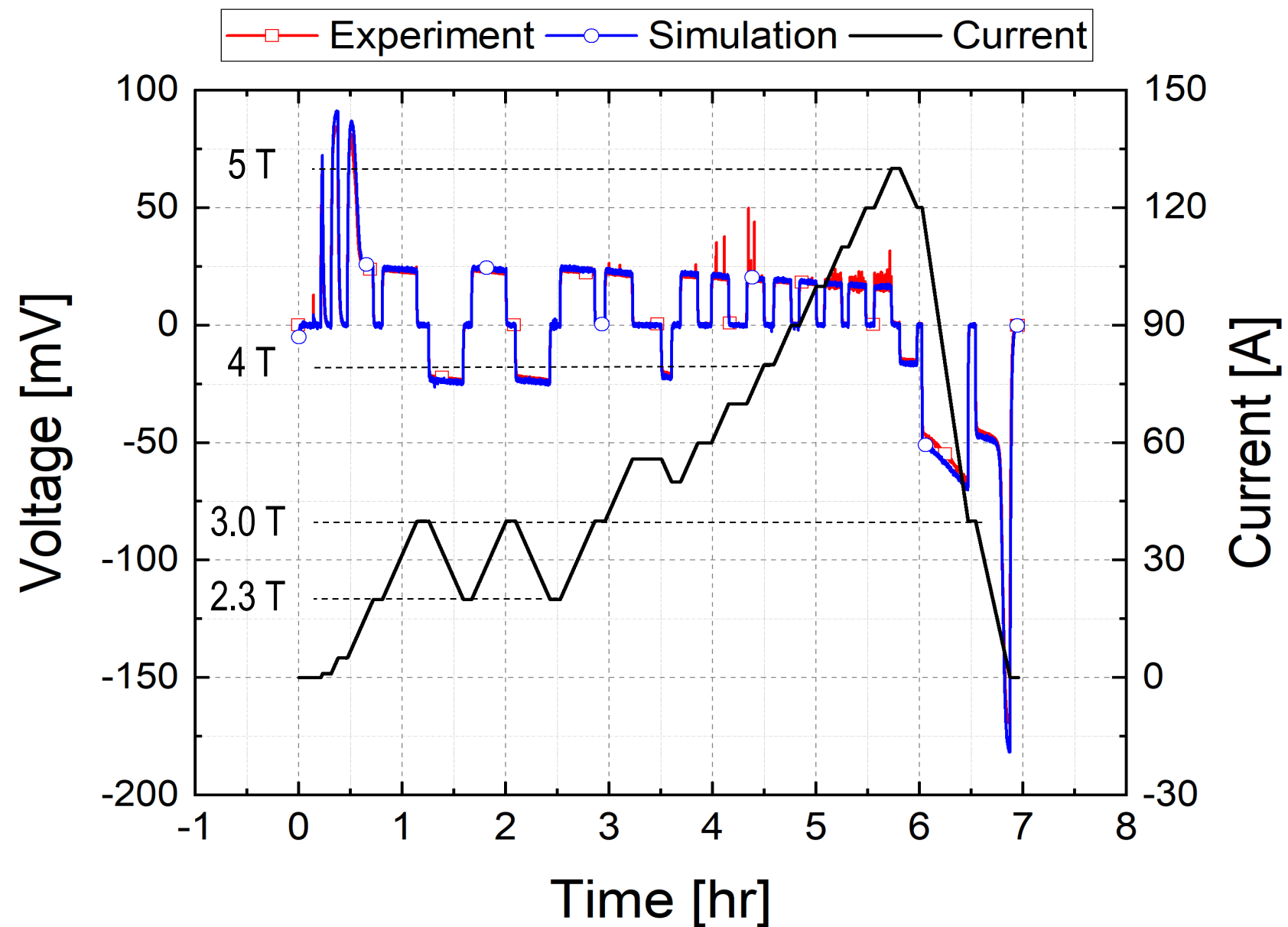

- 2023.02 : HTS Magnet fabrication start
- .08 : Central field of 5 T was achieved
- .11 : Vacuum pipe fabrication was started
- 2024.02 : Dedicated cryostat fabrication was started
- .07 : Assembly of (1) the magnet, (2) the pipe & (3) the cryostat
- .08 : Disassembly of the magnet due to insulation breakdown when the power-on
- .10 : Coil-set repair & 2nd assembly
- .11 : Second power-on test and disassembly to improve thermal insulation (adding more MLI sheets)

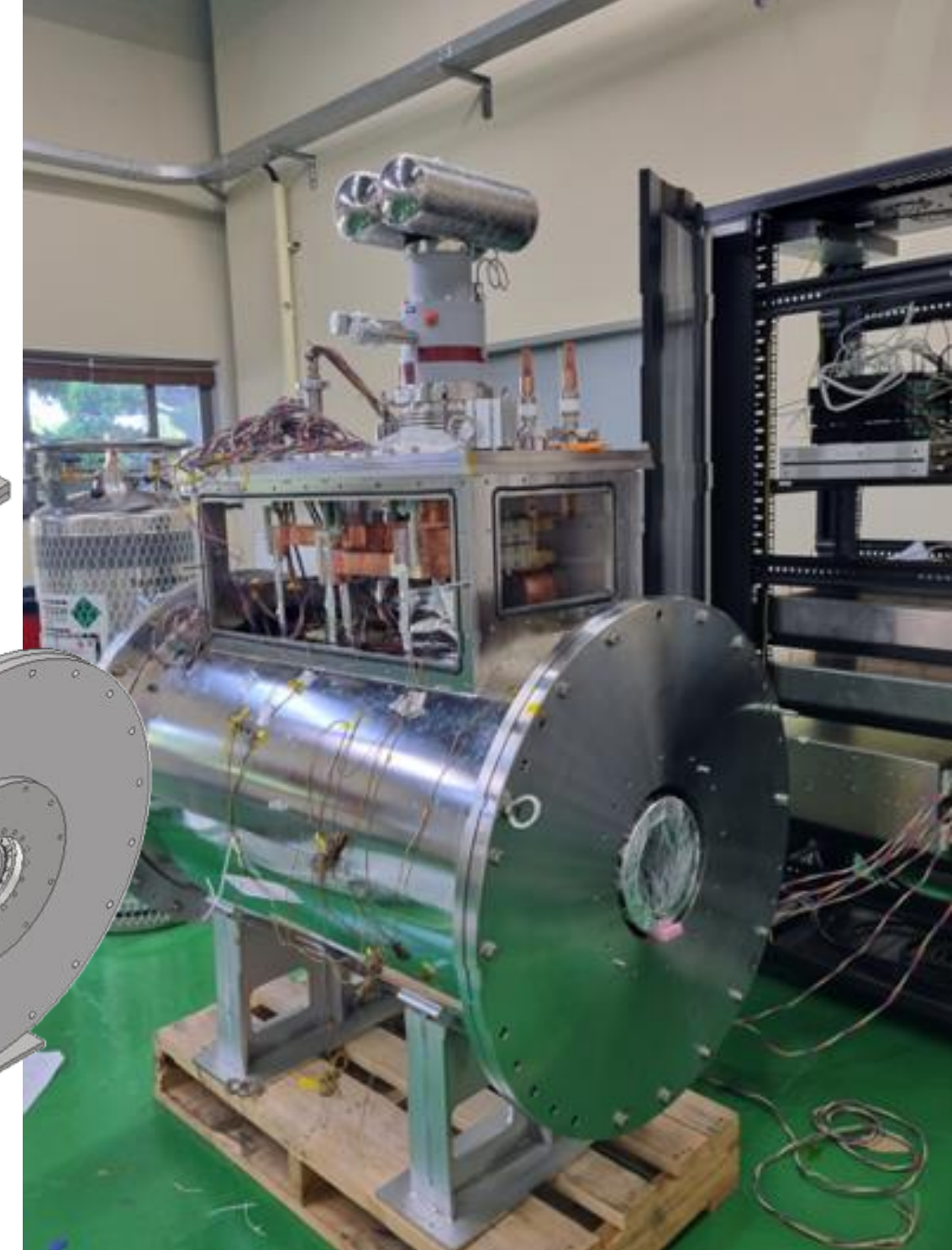
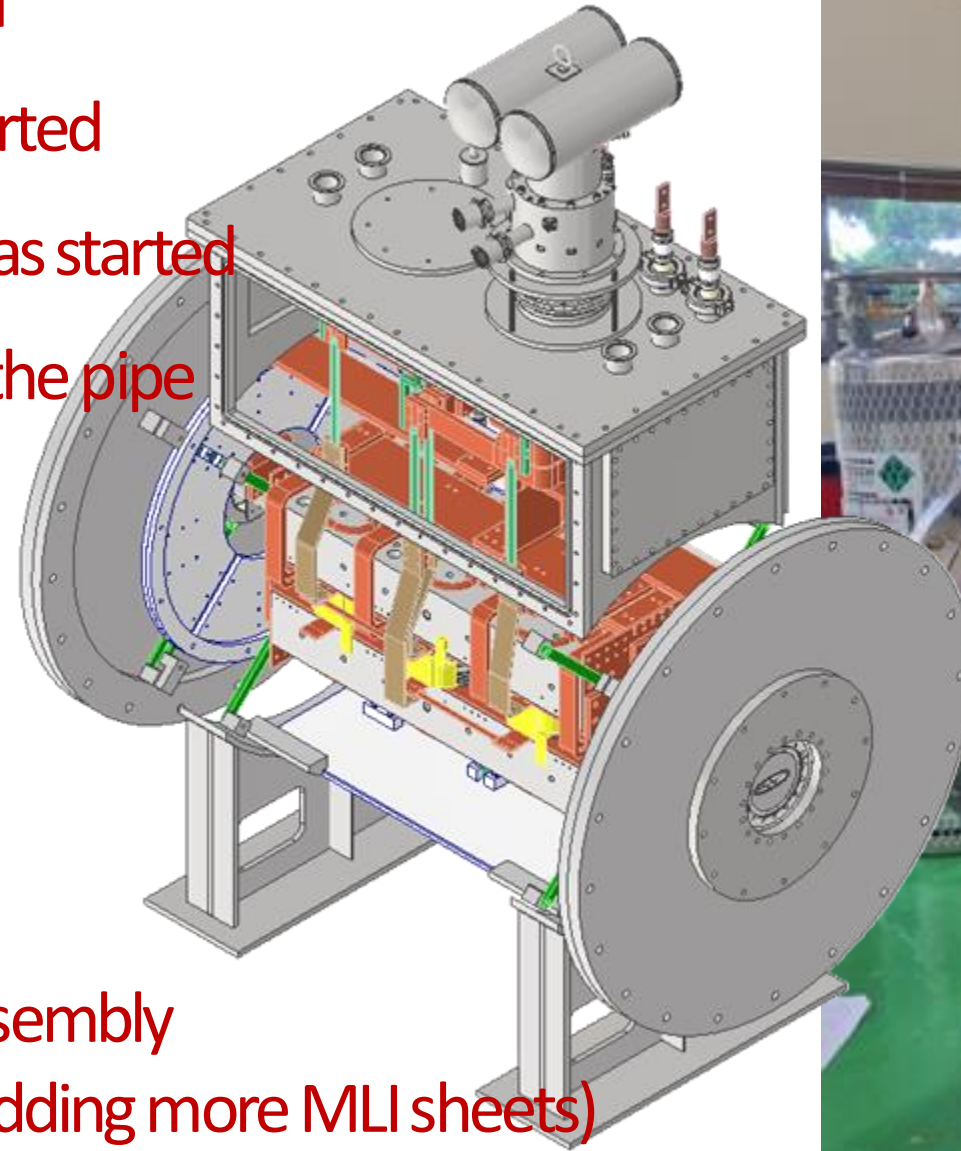

- 2024.12 : Turbo pump was added
- 2025.01 : Powering test
- .02 : Reached 4.5 T at 20 K ...
Cryogenic system requires upgrading
Cooling capacity is presumed to have been underestimated
- .04 : Long-term operation test initiated
- On-going work
 - Magnetic field measurement in vacuum and cryogenic environment to determine operational current-pairs
- Next step ?
 - Design of a girder, support structure, and bellows for a machine study

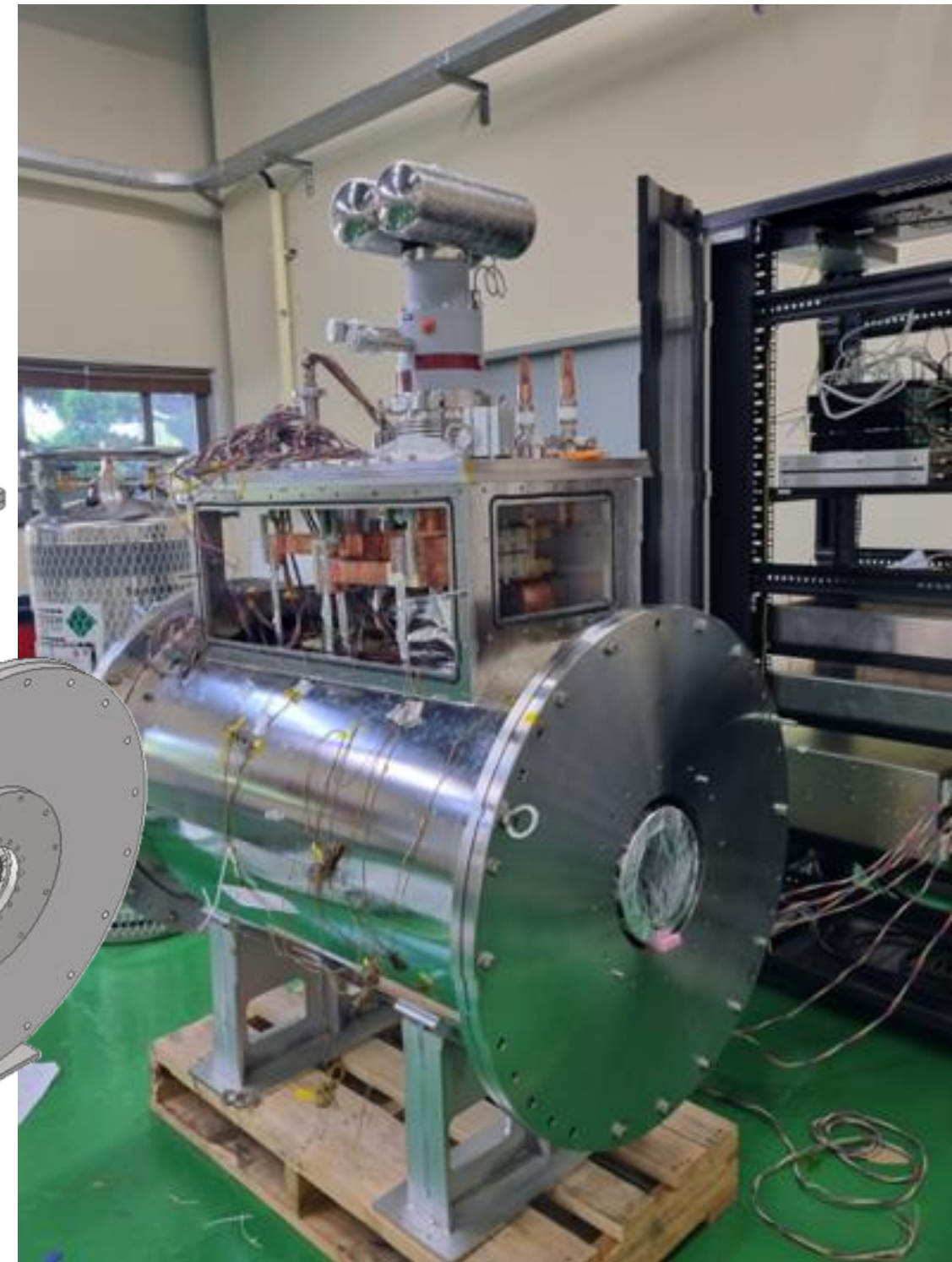
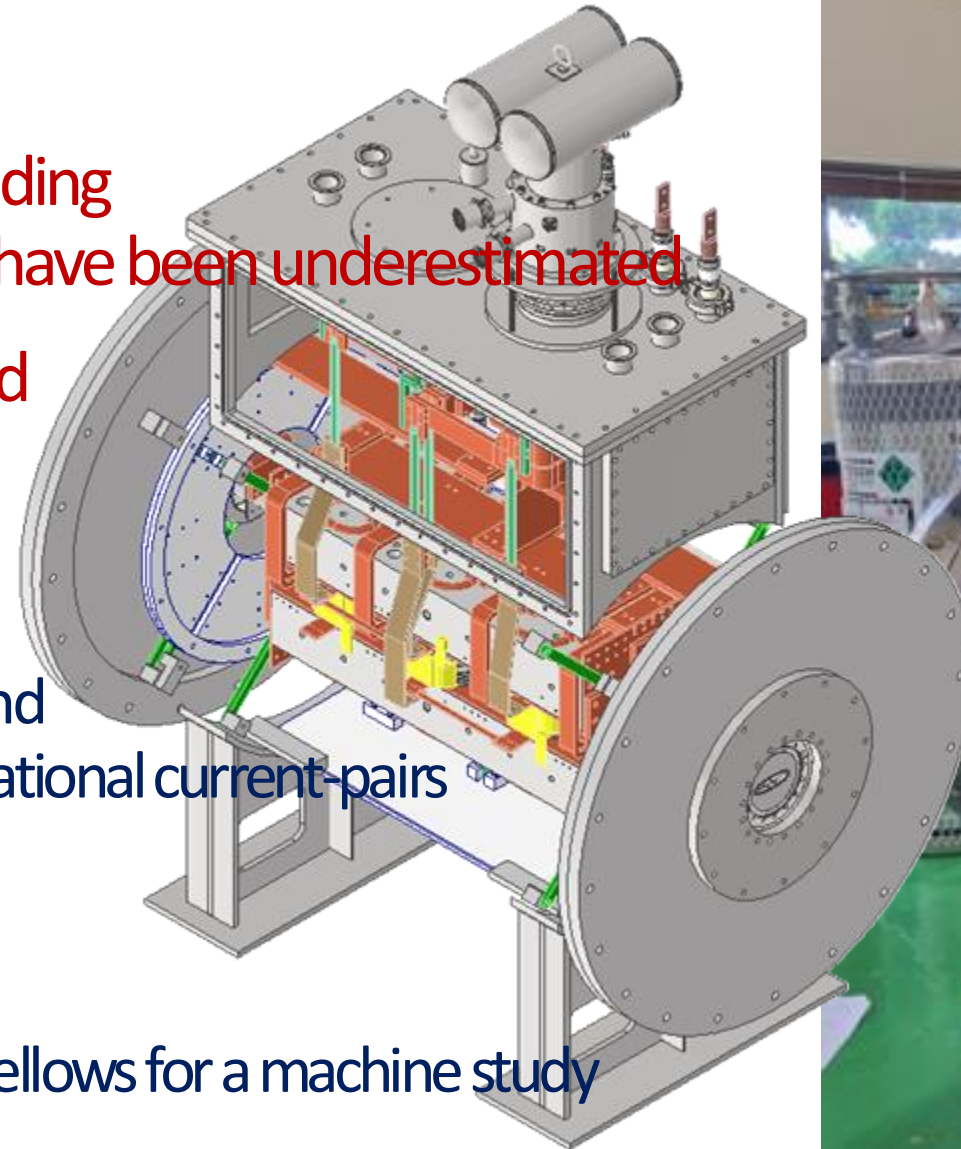

- Since 2020, we have been conducting HTS-based magnet development research for future light source magnet technology with Seoul National University.
- The prototype of 5-tesla wiggler based on HTS with No-insulation technology and LHe-free conduction cooling was successfully fabricated and tested (Aug. of 2023).
 - Central magnetic field strength of 5.02 T was experimentally vitrified without any quench.
 - The core temperature was 8.8 kelvin when the field strength was 5.02 T.
- The magnet was successfully assembled with the dedicated cryogenic system and the vacuum chamber
 - It was repaired two times:(1) the insulation breakdown problem and (2) thermal insulation problem
- Currently, we are preparing a precise field-mapping (2025) and a beam test.

Thank you for your attention

