

CONSTRUCTION OF CONDUCTING COOLING SYSTEM FOR SUPERCONDUCTING CAVITIES

Hayato Abiko

Research center for Accelerator and Radioisotope Science (RARiS)
Tohoku University

Superconducting accelerator

- We are currently conducting fundamental research on the production of medical RI using electron linac.
- In particular, superconducting electron accelerators have the potential to enable large-scale production of RI for nuclear medicine.

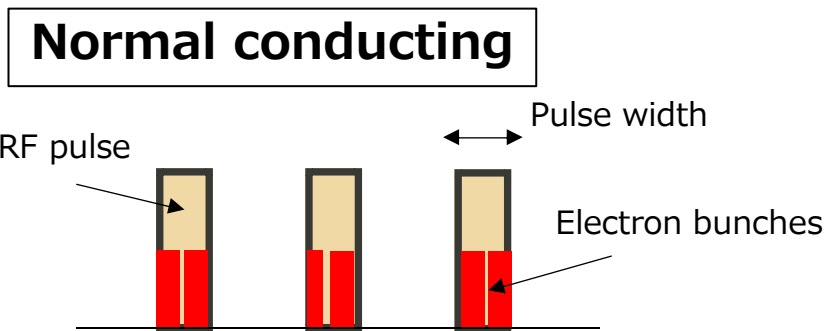

- **Pulse** mode operation
- RF duty < 1%
- Average current : ~ 1 mA

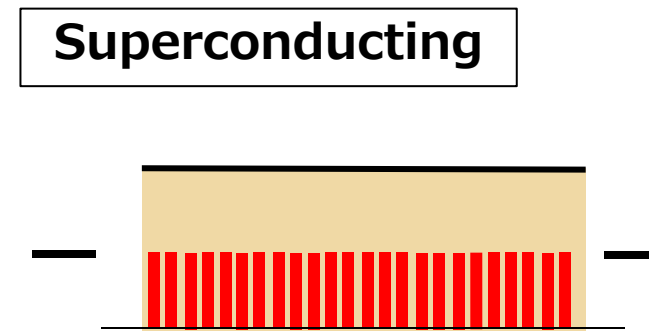

- **CW** mode operation
- Average current : > 10 mA
- Cavity cooling : Liquid He

- **With superconducting accelerators, continuous beam acceleration enables the generation of high currents.**

Issue in Nb cavity

- Niobium is typically used for the superconducting cavity.
- Niobium cavity requires cooling down to **2 K** with **liquid He**.
 - ➔ Various equipment is necessary to maintain the cooled state.

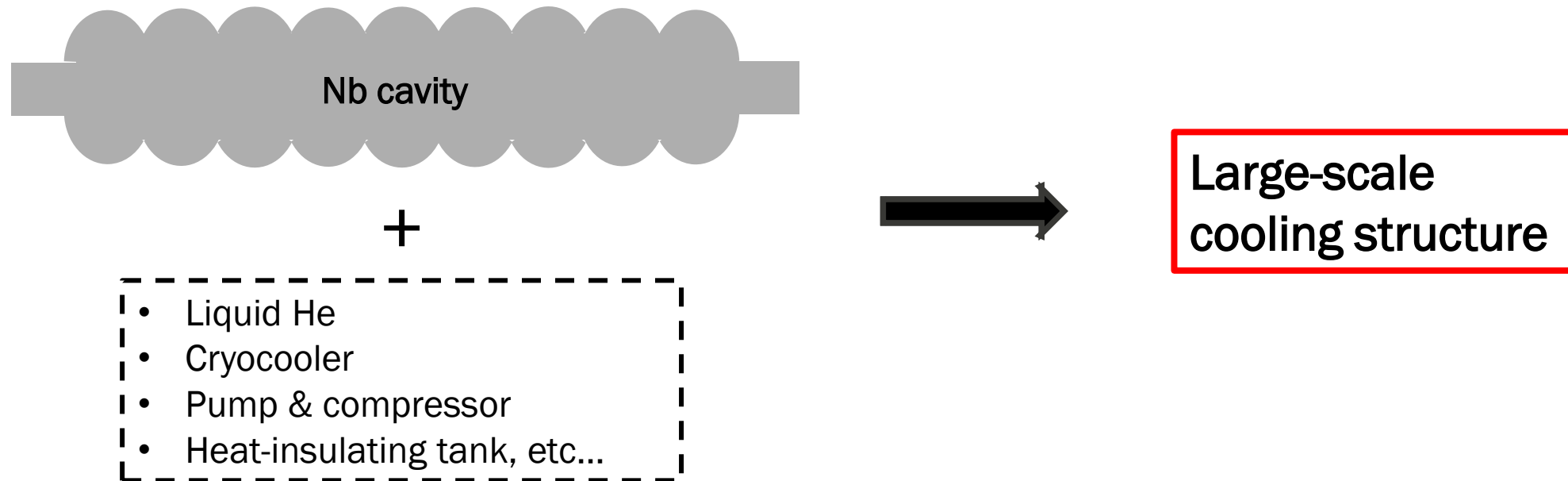

- **it is so difficult for small-scale facilities to operate superconducting accelerators.**

Nb₃Sn SRF Cavity

Nb₃Sn

- Critical temperature : T_c of **Nb₃Sn (18 K) > Nb (9 K)**
- **4 K operation available.**
 - **Conduction cooling** with compact cryocoolers.
- **Cooling without liquid helium.**
 - Operation feasible in small-scale facilities.
- **High Q-value**
 Q_0 comparable to a Nb cavity at 2 K (with only 4.2 K cooling)

$$Q_0 = \frac{\omega_0 U}{P_c} \left(\begin{array}{l} \omega_0 : \text{resonant frequency} \\ U : \text{stored energy in a cavity} \\ P_c : \text{power dissipated on a cavity surface} \end{array} \right)$$

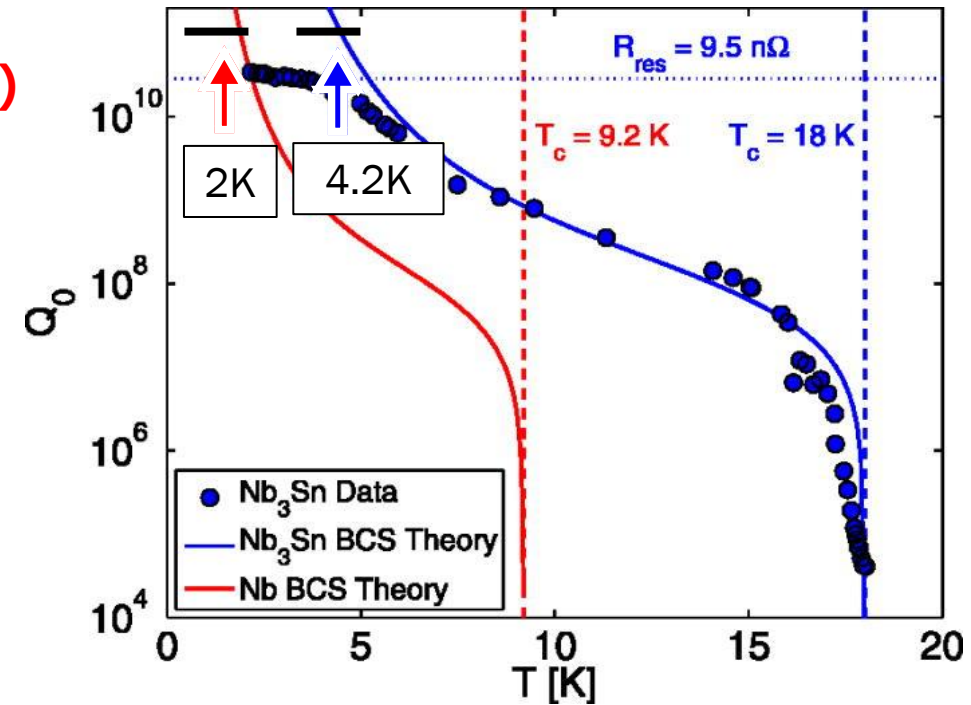

S. Posen, M. Liepe, and D. L. Hall, Appl. Phys. Lett. **106**, 082601 (2015)

Cryomodule for 3GHz cavity

- At RARiS, Tohoku Univ, we are developing a cooling system using a **3 GHz single-cell Nb cavity** as part of the effort toward a Nb₃Sn superconducting electron linac.
- **Final goal:** Install S-band single-cell cavity & cryomodule in RARiS test accelerator (t-ACTS)
 - ➔ Beam acceleration test



3GHz Nb cavity

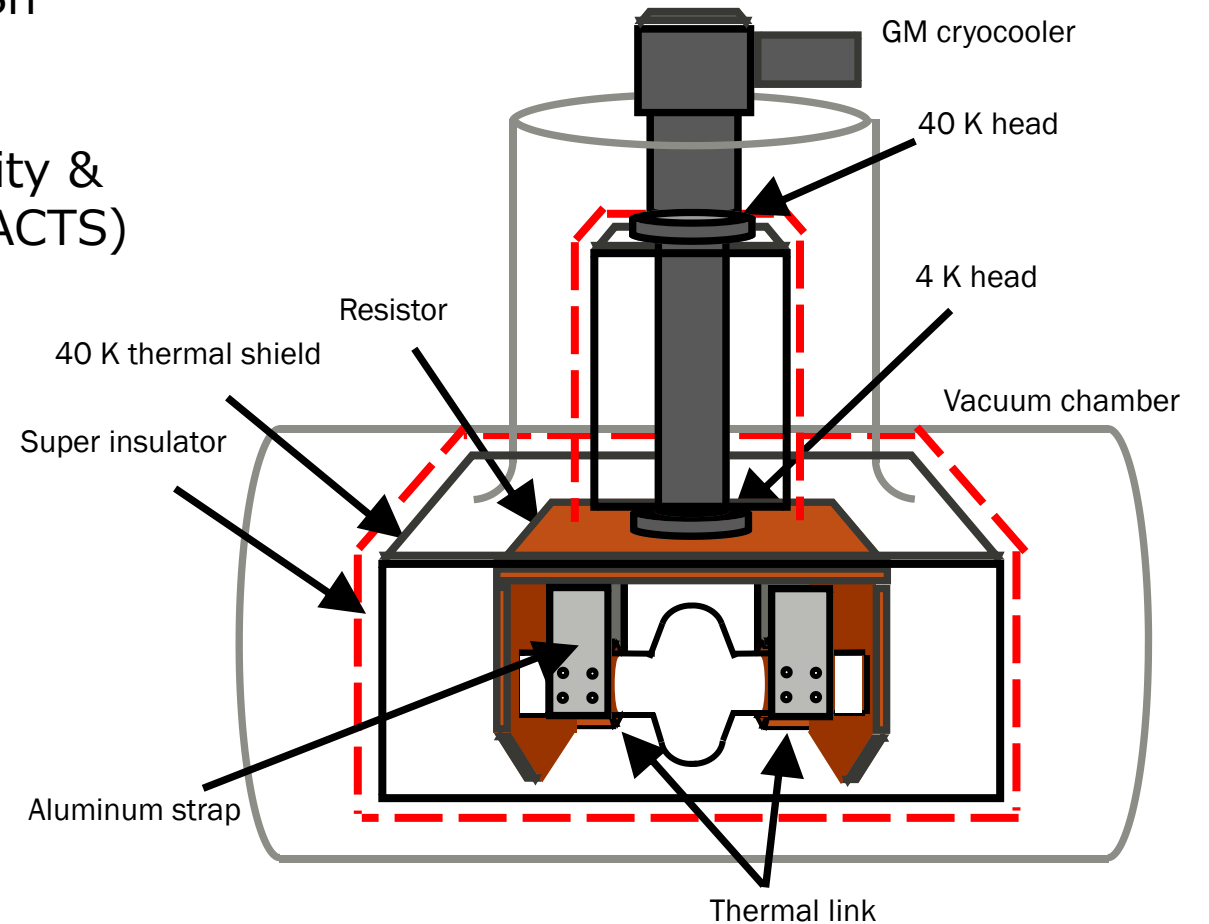

Current work

- In the cooling test, we confirmed that **conduction cooling of the cavity with a GM cryocooler is feasible.**
- Resonant frequency measurements also revealed the **frequency shift of the cavity before and after cooling.**

Next steps

- Redesign and fabrication of the cavity cooling structure. (e.g., thermal links)
- Design for installation into the beamline.

Back up

Cooling test

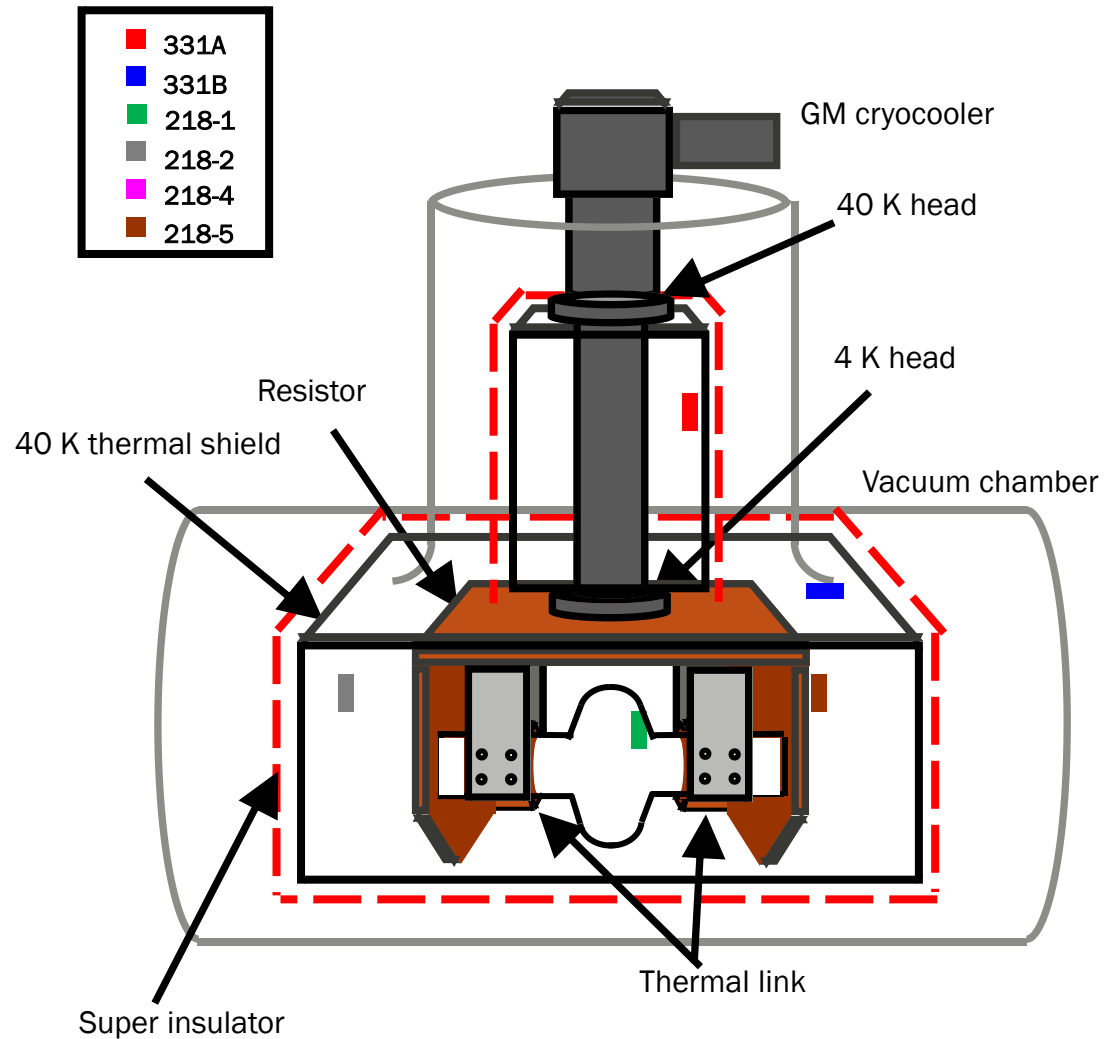

- We conducted a test to evaluate the cooling performance of the cavity using a GM cryocooler.
- For temperature measurement, **Cernox sensors** (well-suited for high sensitivity in the cryogenic region) were used.
- 40 K region : 331A, 331B, 218-2
4 K region : 218-1, 218-4, 218-5

Cooling test

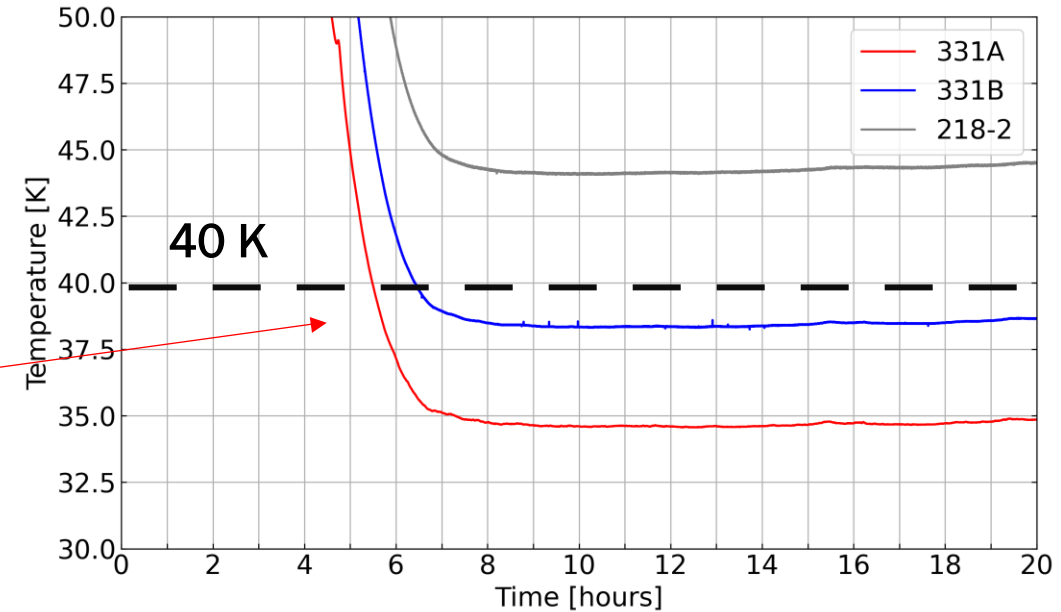
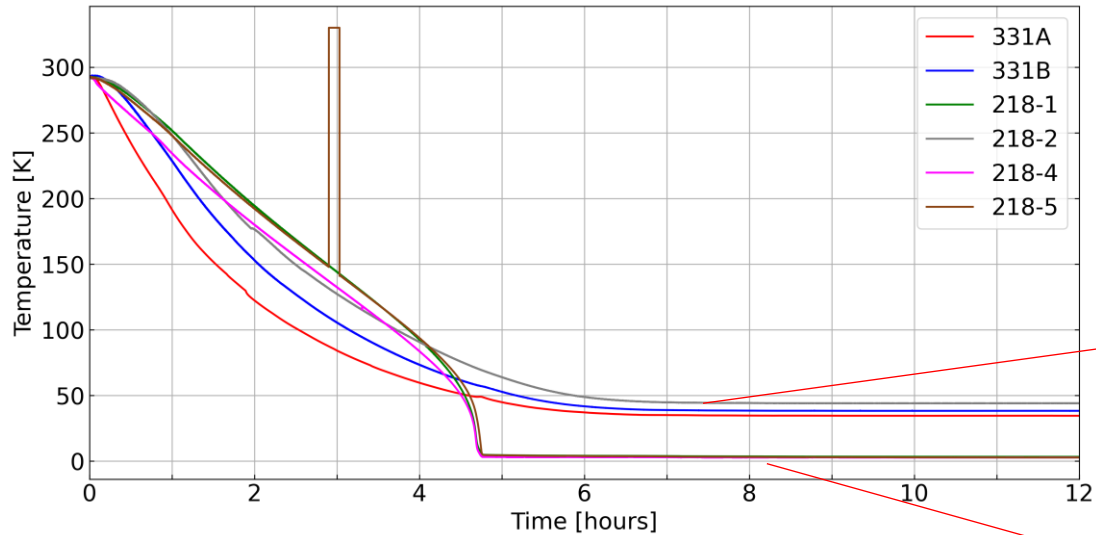

- In each region, **the cavity was cooled close to the target temperature.**
- Sensor 218-2 maintained a slightly higher temperature of 44 K
 - ➔ due to distance from 40 K stage
- In the 4 K region, all sensors were kept below 4 K.
 - ➔ **It is possible to cool the cavity to 4 K with this system.**

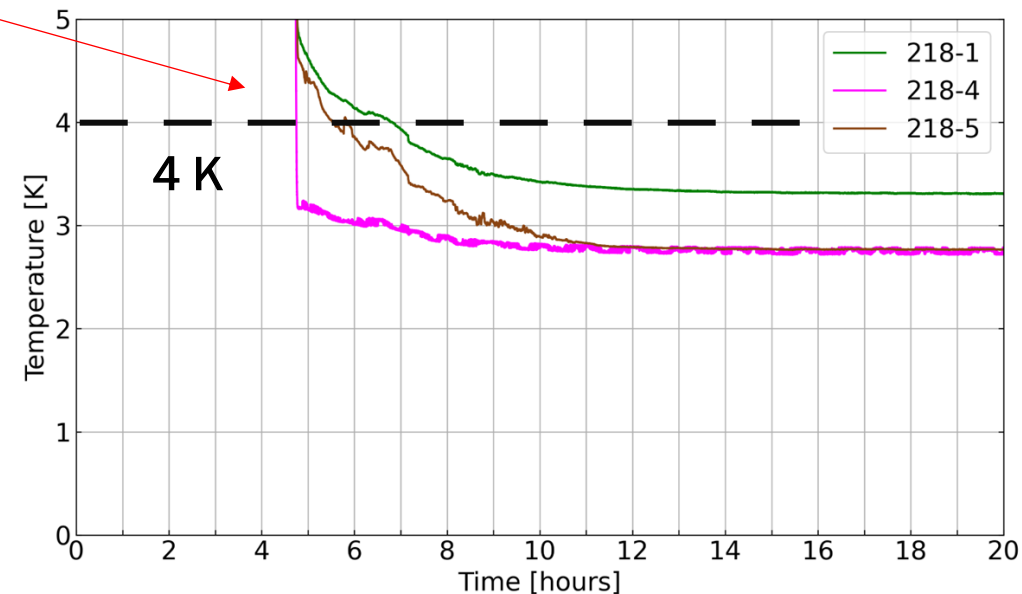

Resonant frequency measurement

- Since superconducting cavities have a very high Q-value, **even a slight frequency shift can prevent stable beam acceleration.**
- The resonant frequency depends on the cavity size, which changes due to thermal contraction during cooling
 - ➔ We measured the variation of the resonant frequency with temperature.

Changes

- mount an **antenna** on the cavity flange.
- route a **cable** through the flange to the outside of the vacuum chamber

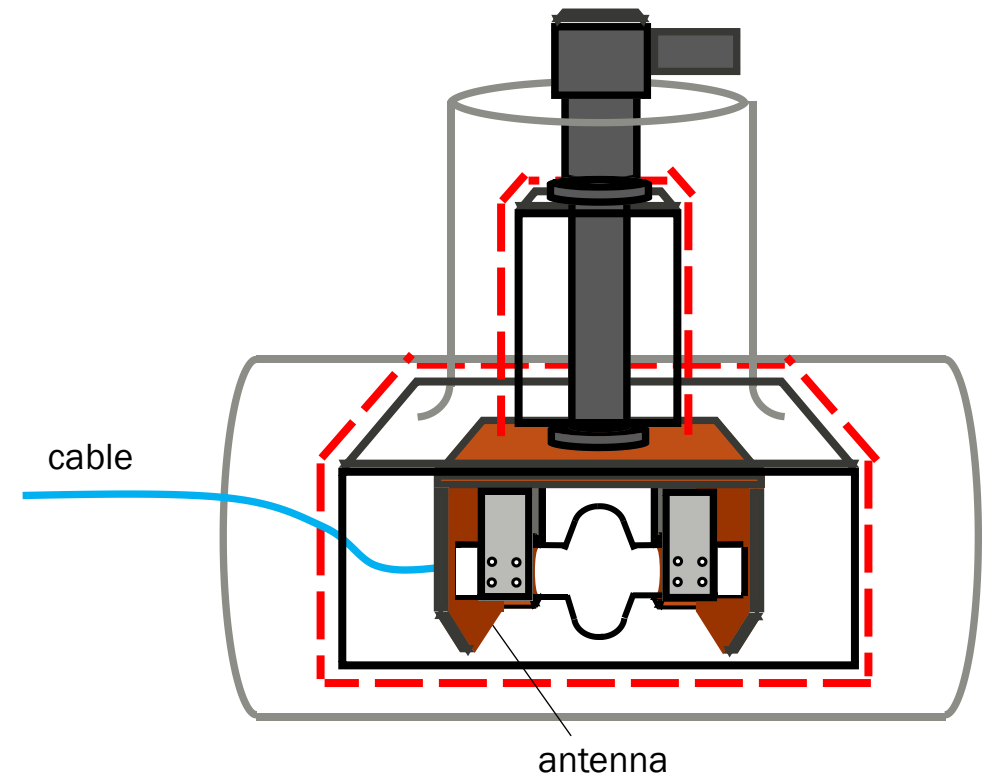

Cable layout

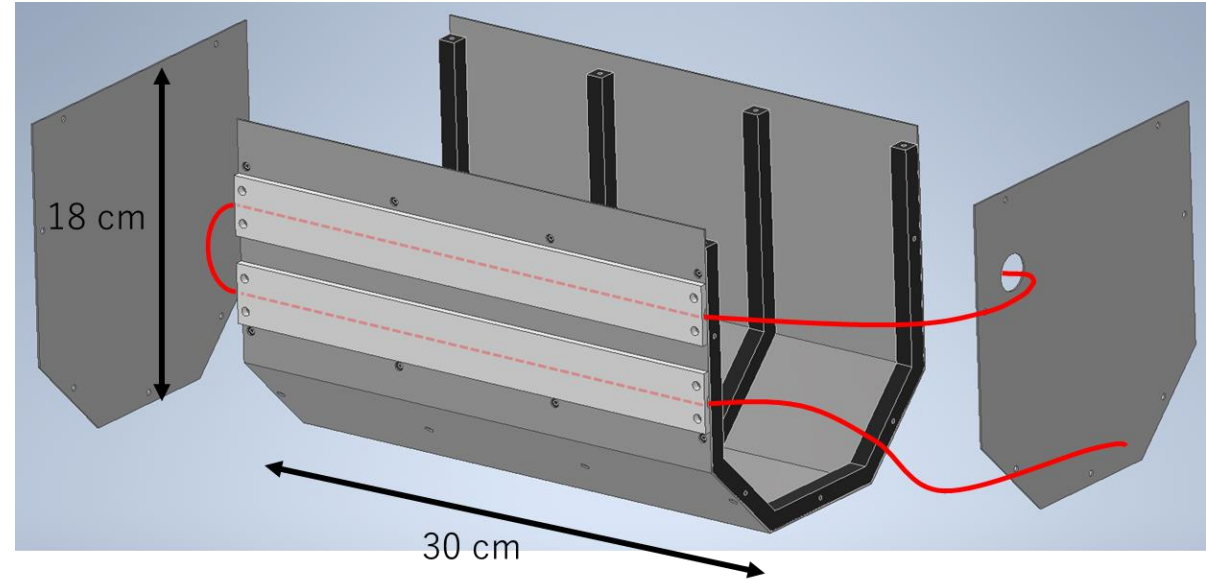
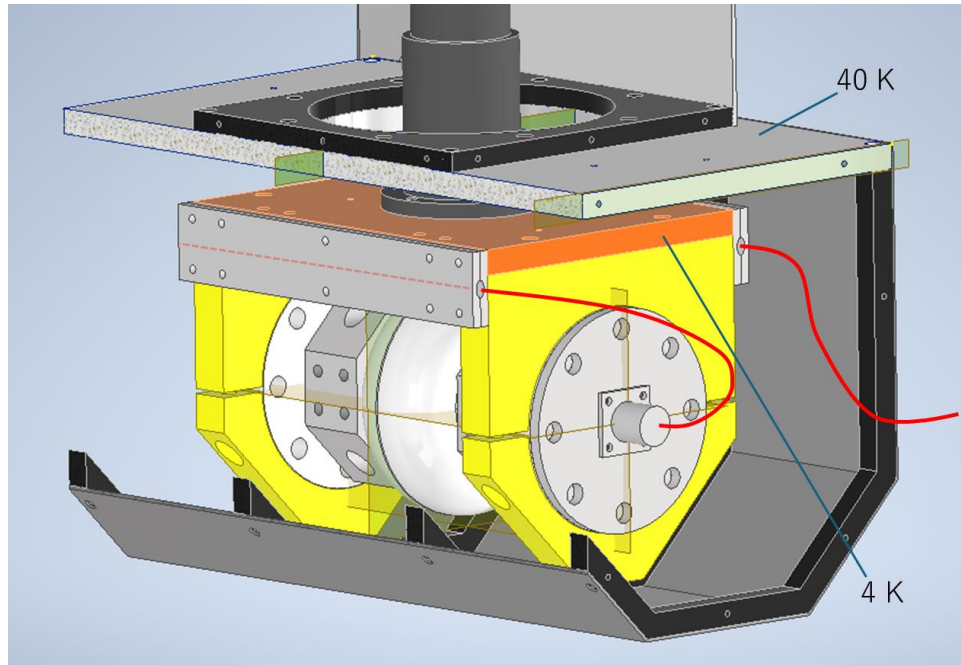

- A structure was fabricated with thermal anchors at 4 K and 40 K stages to suppress heat inflow through the cables.

Cable layout

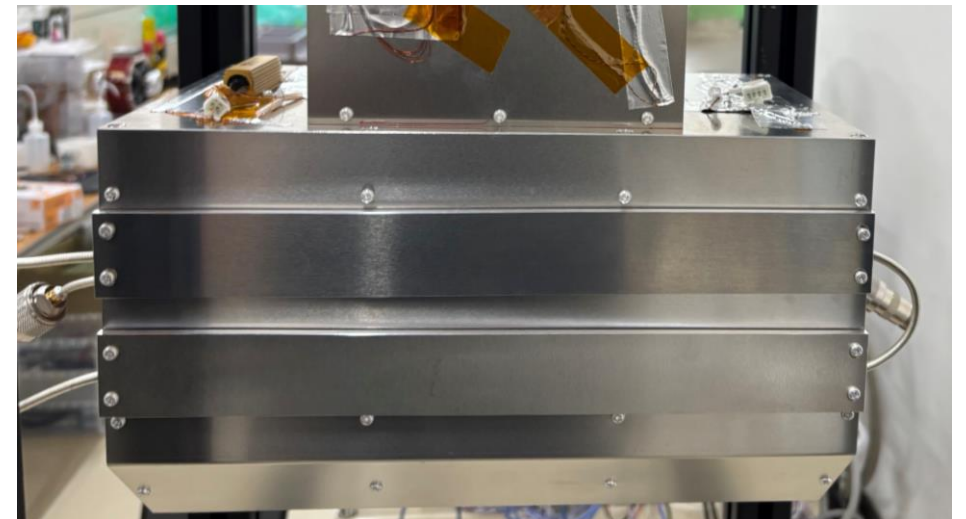
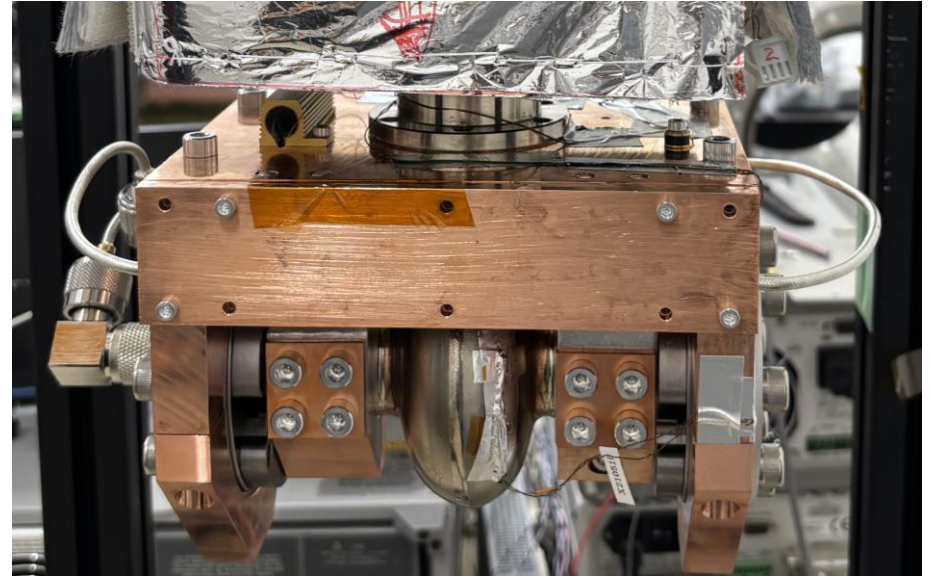
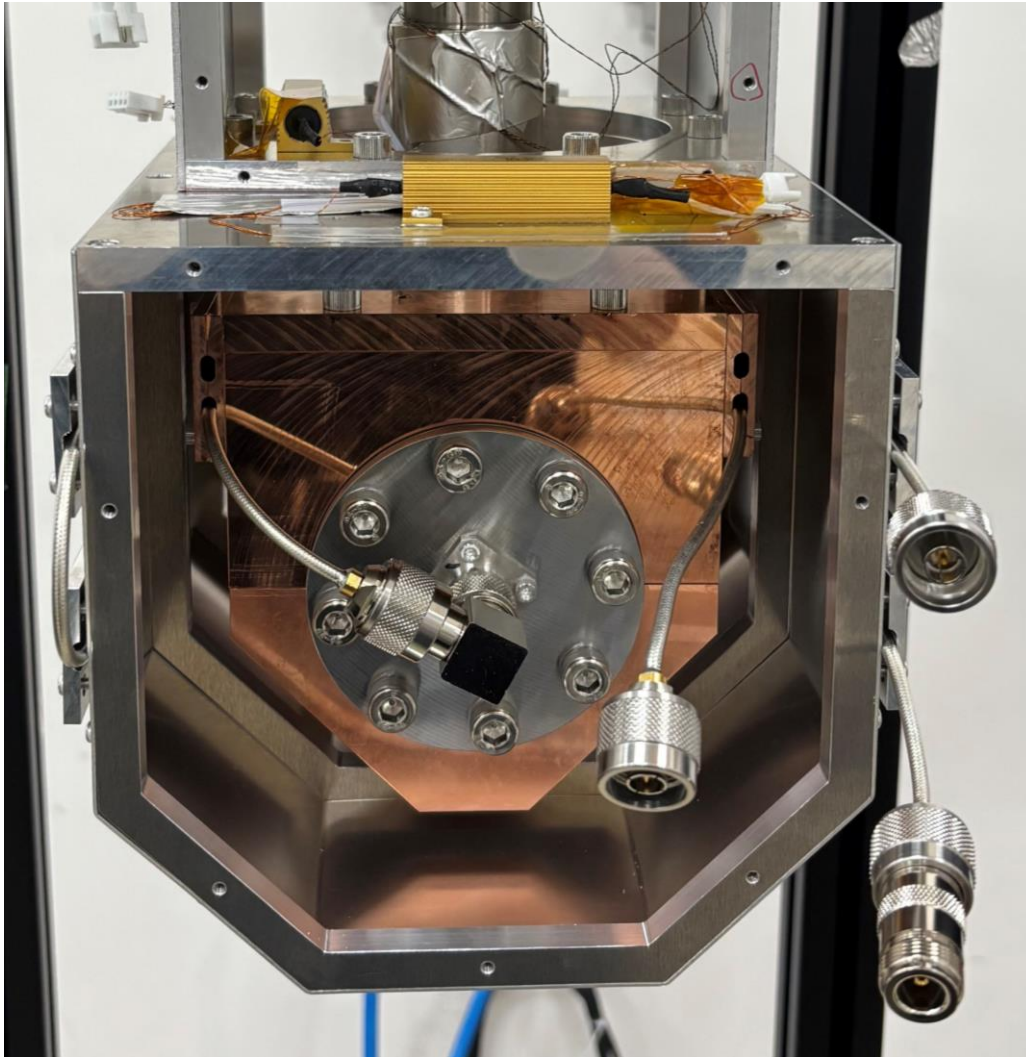

Set up

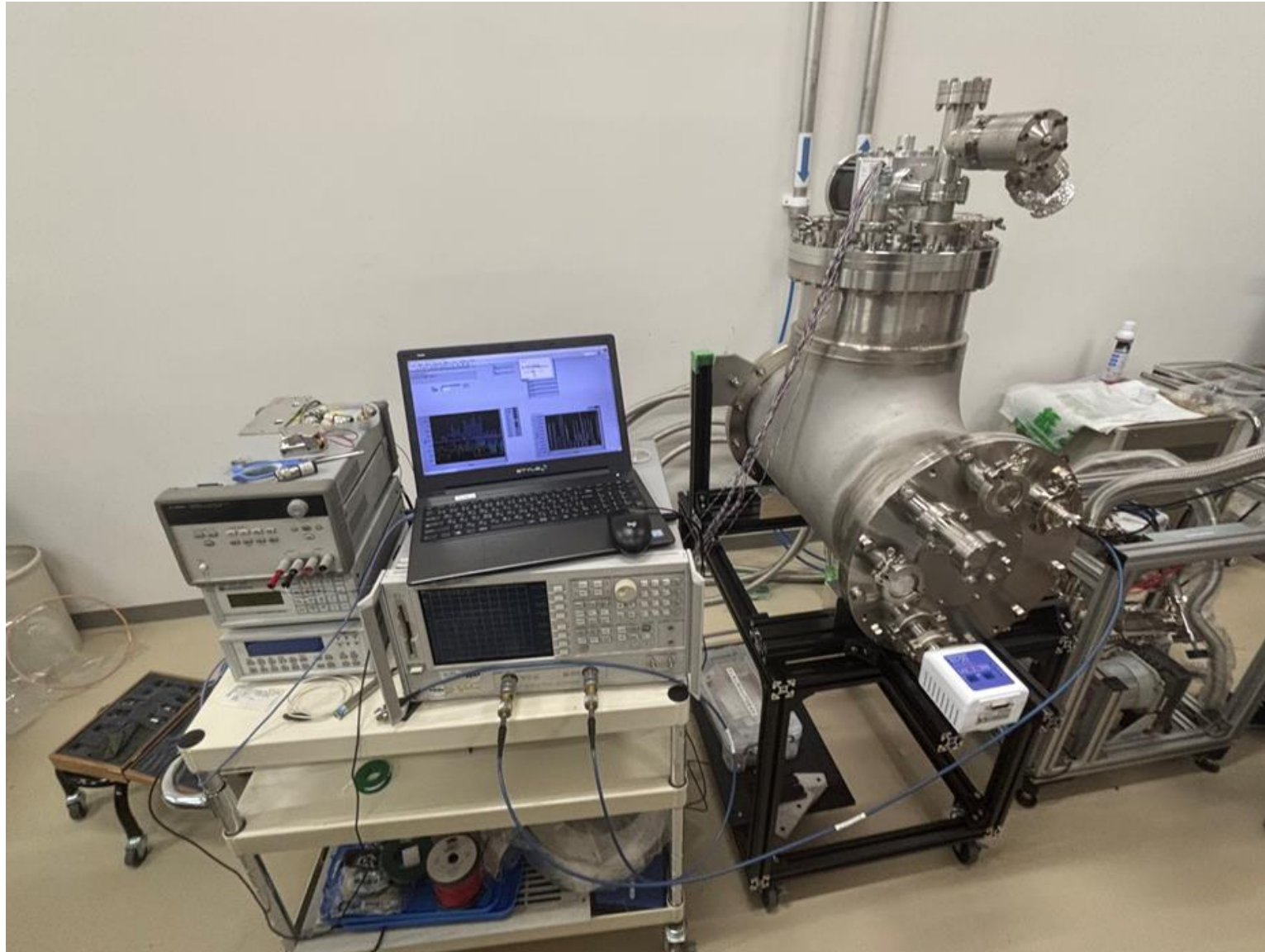

Measurement result (Temperature)

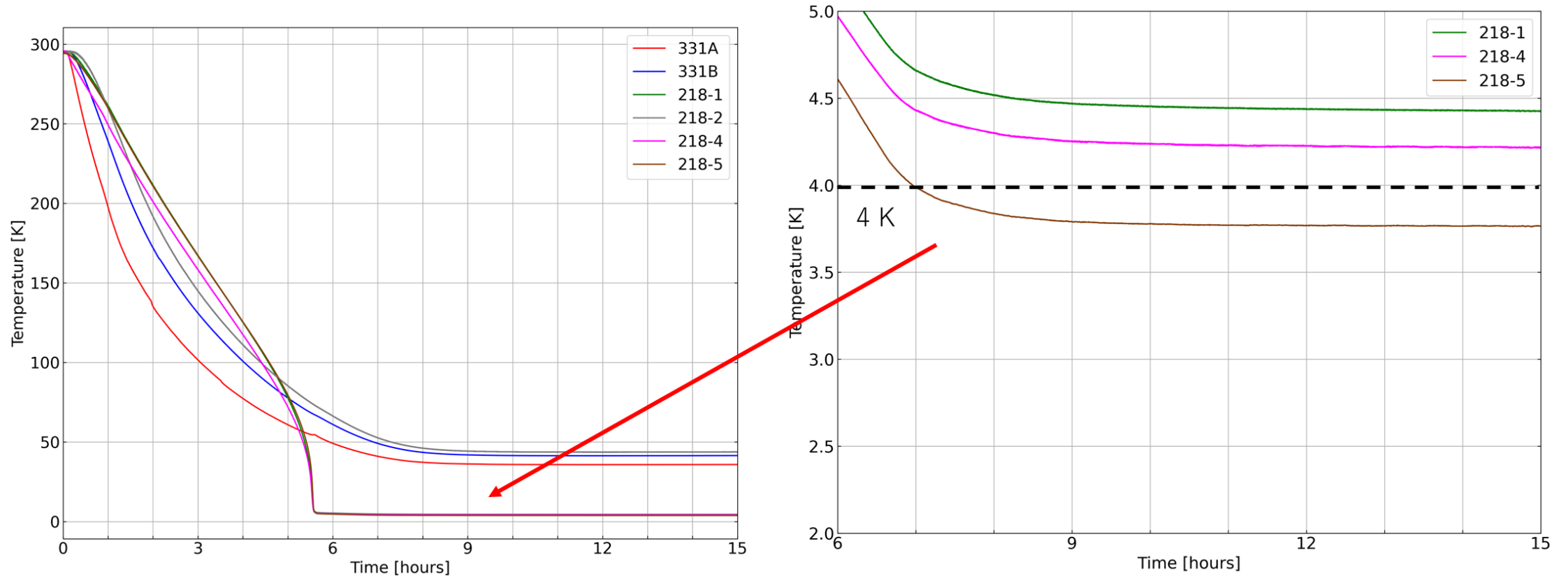

- Cavity temperature slightly above 4 K target
 - ➔ improve the efficiency of conduction cooling.
(Further suppression of heat inflow through the cables and optimization of the thermal links)

Measurement result (f_0)

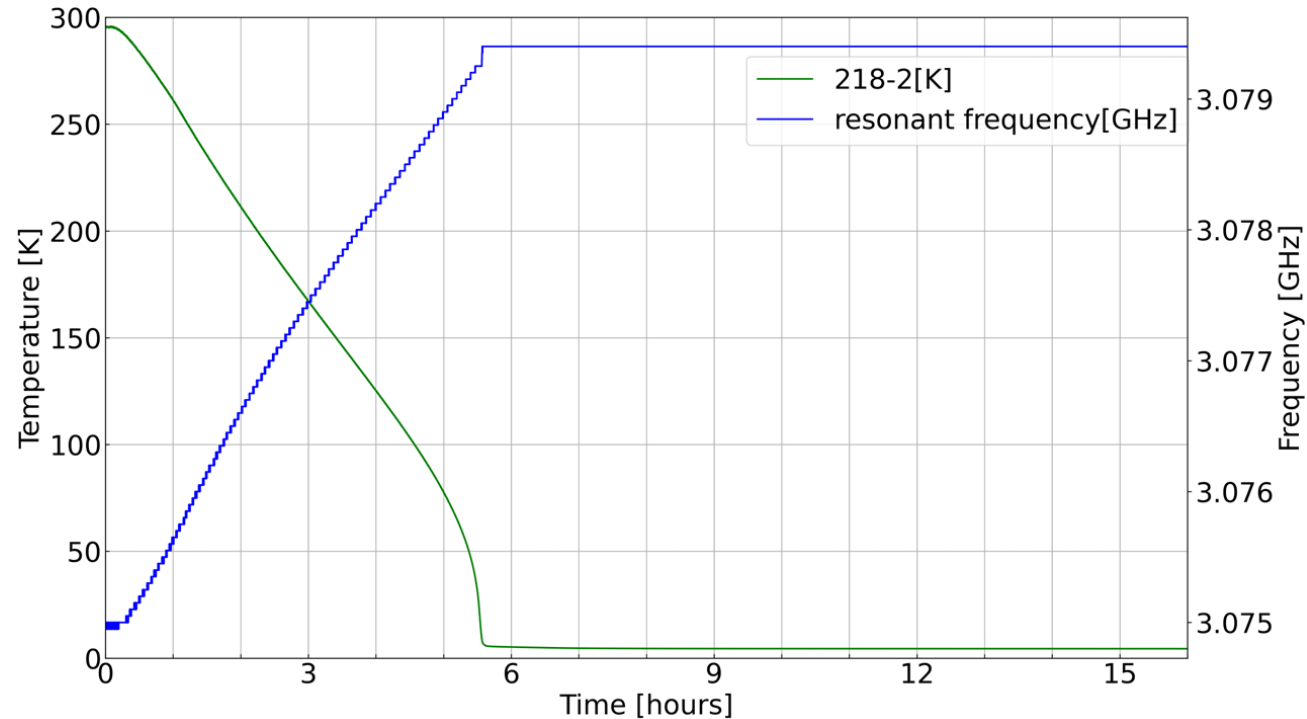

- Cooling caused the cavity to contract, resulting in a shift of the resonant frequency to a higher value.

- Measurement shift:

$$\Delta f = 5.375 \text{ [MHz]}$$