

DarQ: Search for dark photons using direct excitations of superconducting qubits

K. Watanabe^A, K. Nakazono^A, T. Nitta^B, S. Chen^C, T. Inada^B, K. Terashi^B, R. Sawada^B, T. Moroi^{A, D}, H. Fukuda^A, T. Sichanugrist^A, S. Shirai^E, A. Noguchi^{E, F, G}

^ADept. of Phys. Univ. of Tokyo, ^BICEPP Univ. of Tokyo, ^CDept. of Phys. Univ. of Kyoto, ^DQUP (WPI), KEK, ^ERIKEN Center for Quantum Computing (RQC), ^FKomaba Institute for Science(KIS), Univ. of Tokyo, ^GInamori Research Institute for Science(InaRIS)

Introduction

Dark photon

- Good DM candidate
- Lighter mass $< \mathcal{O}(\mu\text{eV})$ \rightarrow behave like a coherent wave
- Electromagnetic interaction \perp **freq. corresponding to DM mass**
Convert into **coherent E-field**

$$\tilde{X}^\mu = \tilde{X}^\mu - \epsilon A^\mu$$

Dark photon interaction-eigenstate
Dark photon mass-eigenstate Ordinary photon Kinetic mixing parameter

Superconducting qubit: transmon

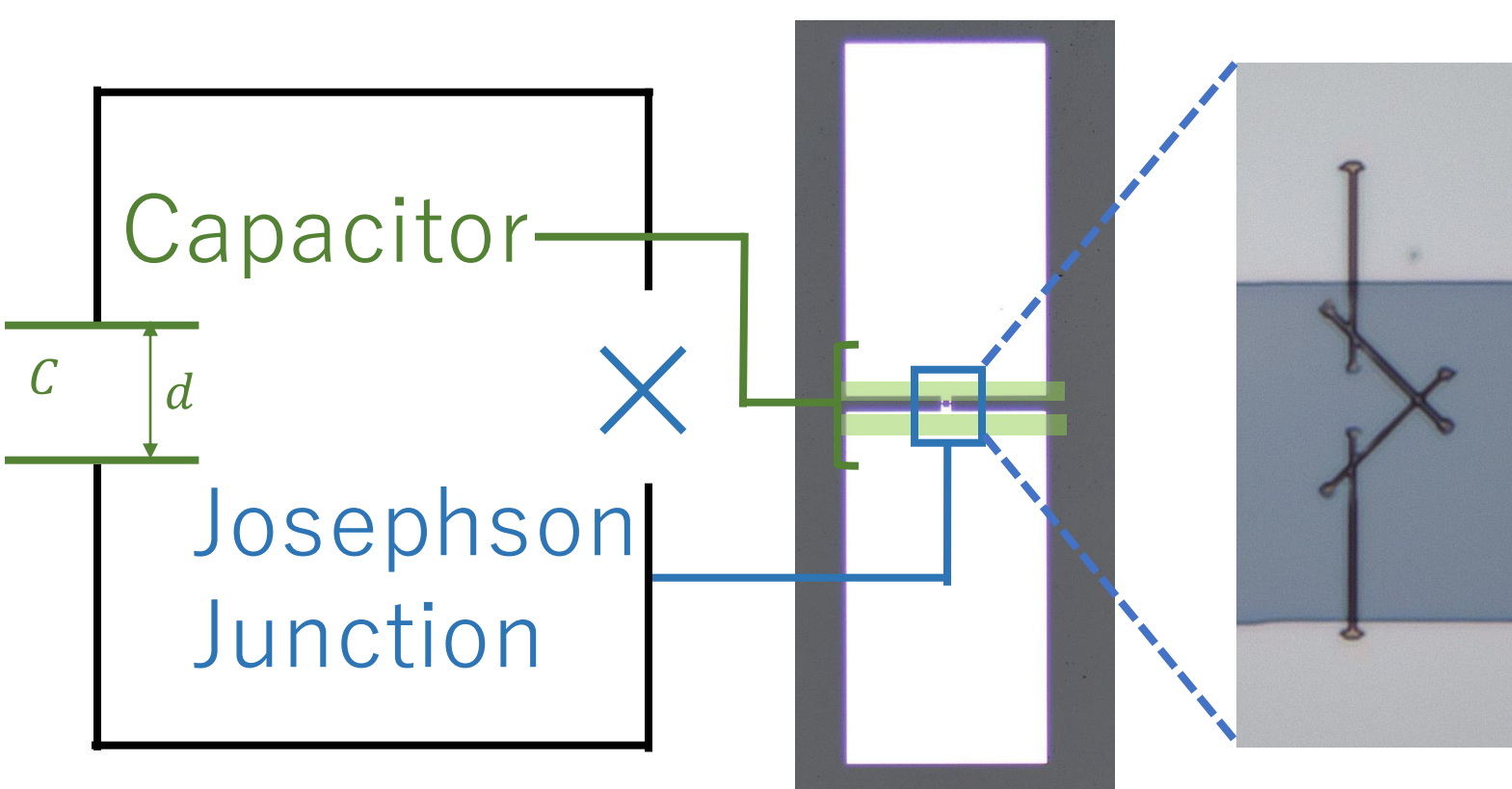

- Excited by **coherent E-field**
- Nonlinear LC circuit
- Josephson Junction works as nonlinear inductance
@ temp. $< T_c(\text{Al}) \sim 1.2 \text{ K}$

Main idea

based on Chen+, PRL 131(21) 211001 (2023)

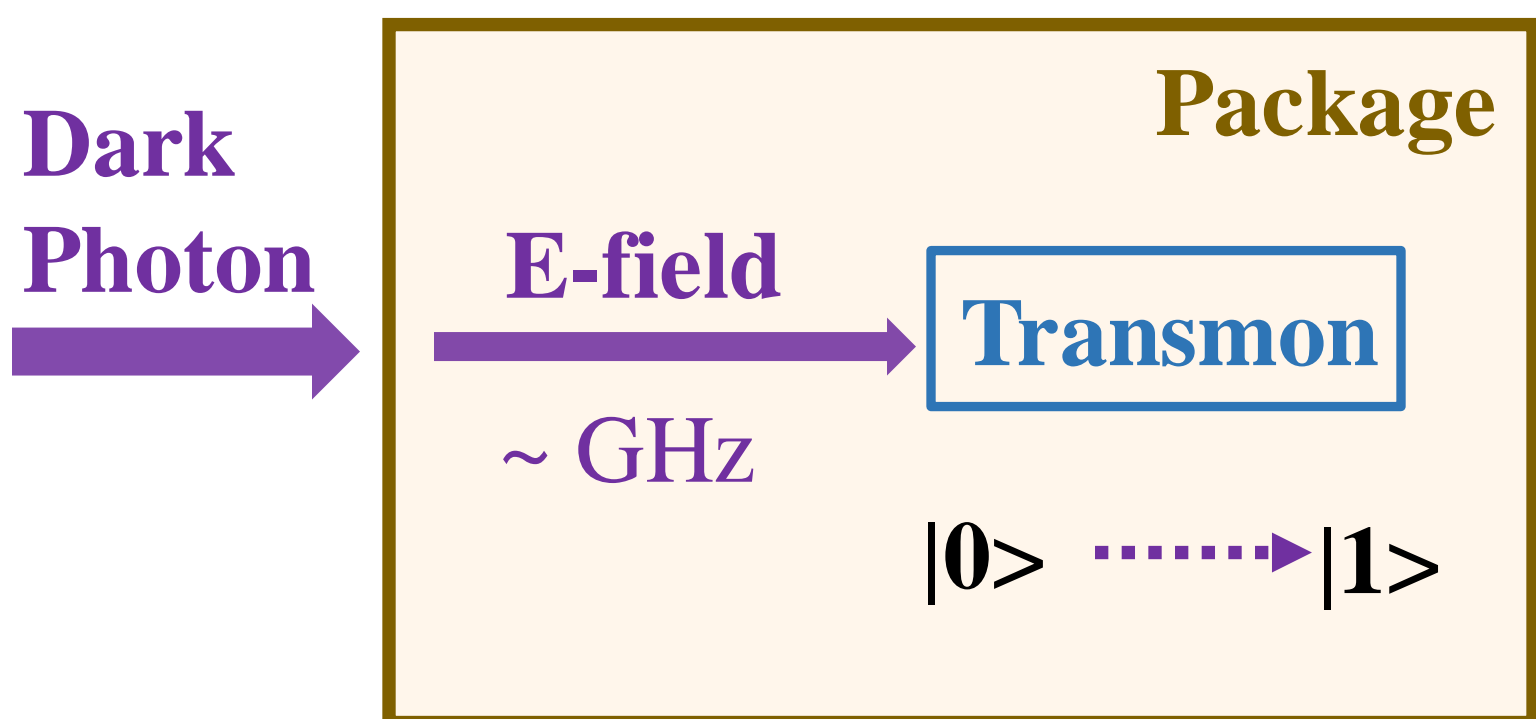

Freq. of DM-converted E-field = Resonant freq. of transmon
 \Rightarrow Excitation to $|1\rangle$

Method

Repetitive counting experiment

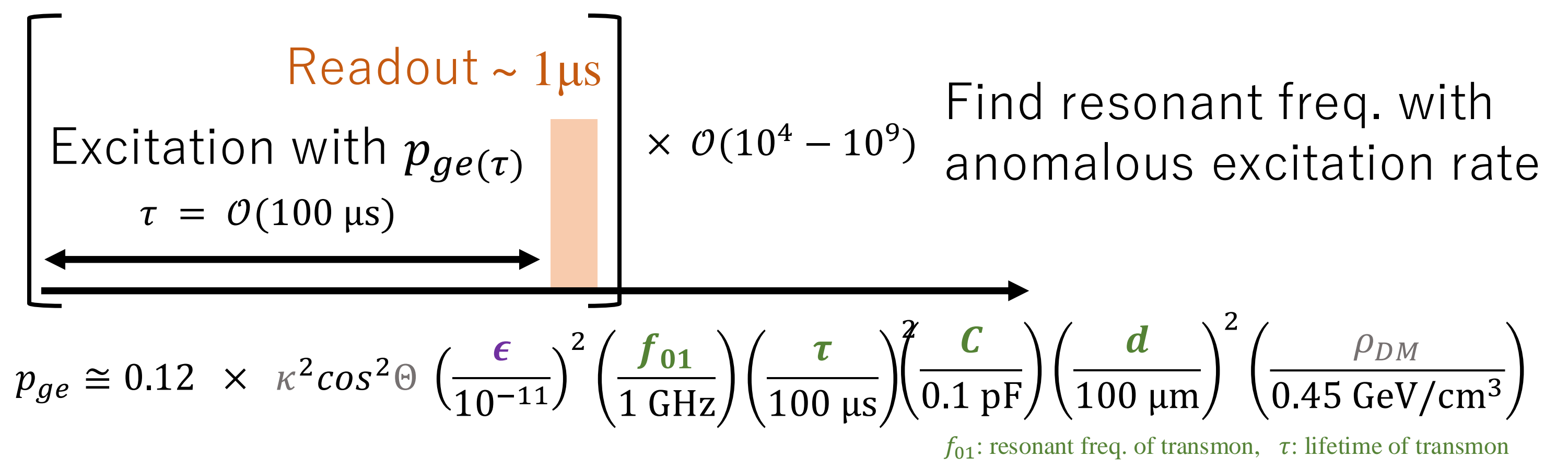

Easy frequency tuning

• SQUID

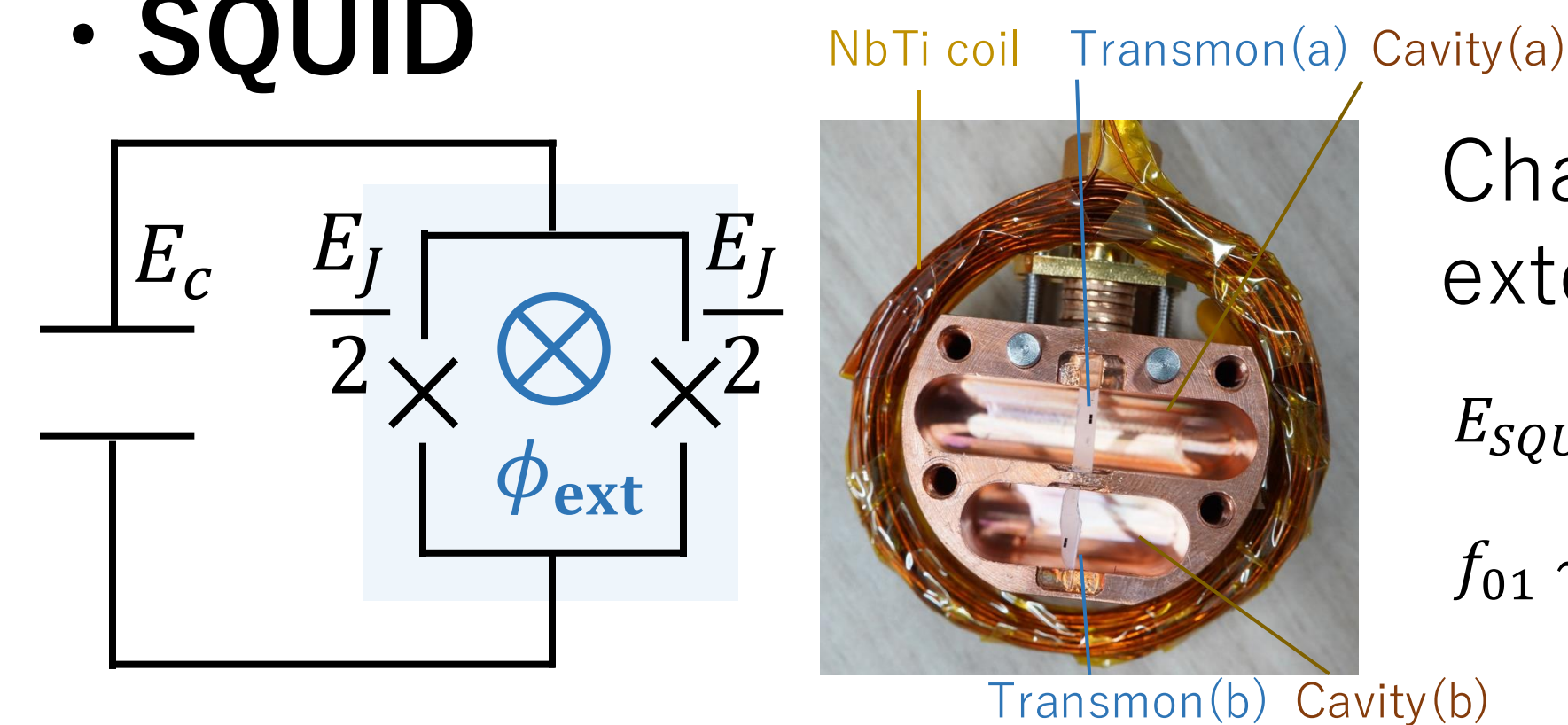

Change resonant freq. through external magnetic flux ϕ_{ext}

$$E_{\text{SQUID}} = E_J \cos \frac{\phi_{\text{ext}}}{2} \quad \phi_{\text{ext}} = \phi_{\text{ext}} \phi_0$$

$$f_{01} \sim \sqrt{8E_{\text{SQUID}}E_C} - E_C$$

• AC Stark shift



Change resonant freq. through Off-resonant tone

$$\Delta f_{01} = \frac{\delta_q \Omega_s^2}{2\Delta_{qs}(\delta_q + \Delta_{qs})}$$

Ω_s : amplitude of off-resonant tone
 δ_q : qubit anharmonicity

RF system

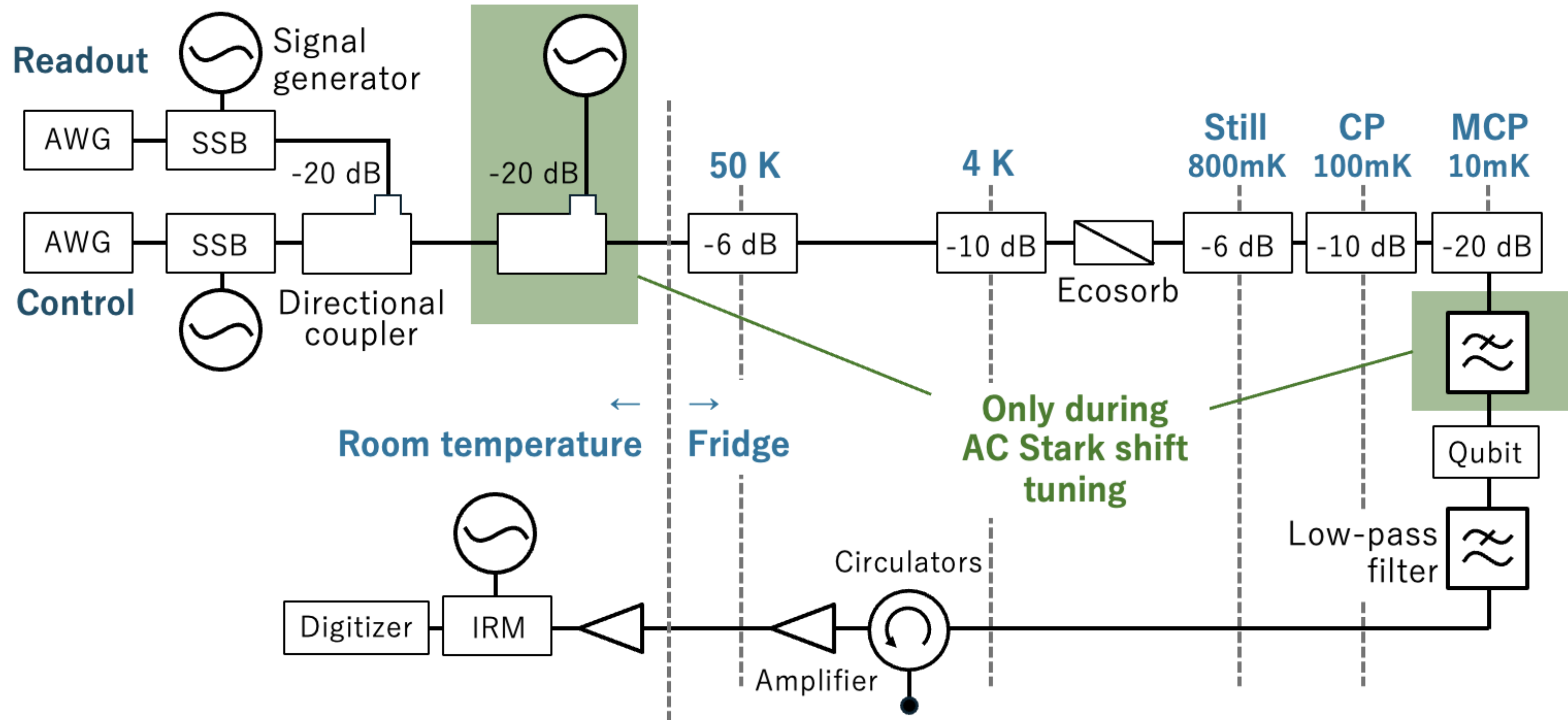

Fabrication

Make transmons by ourselves

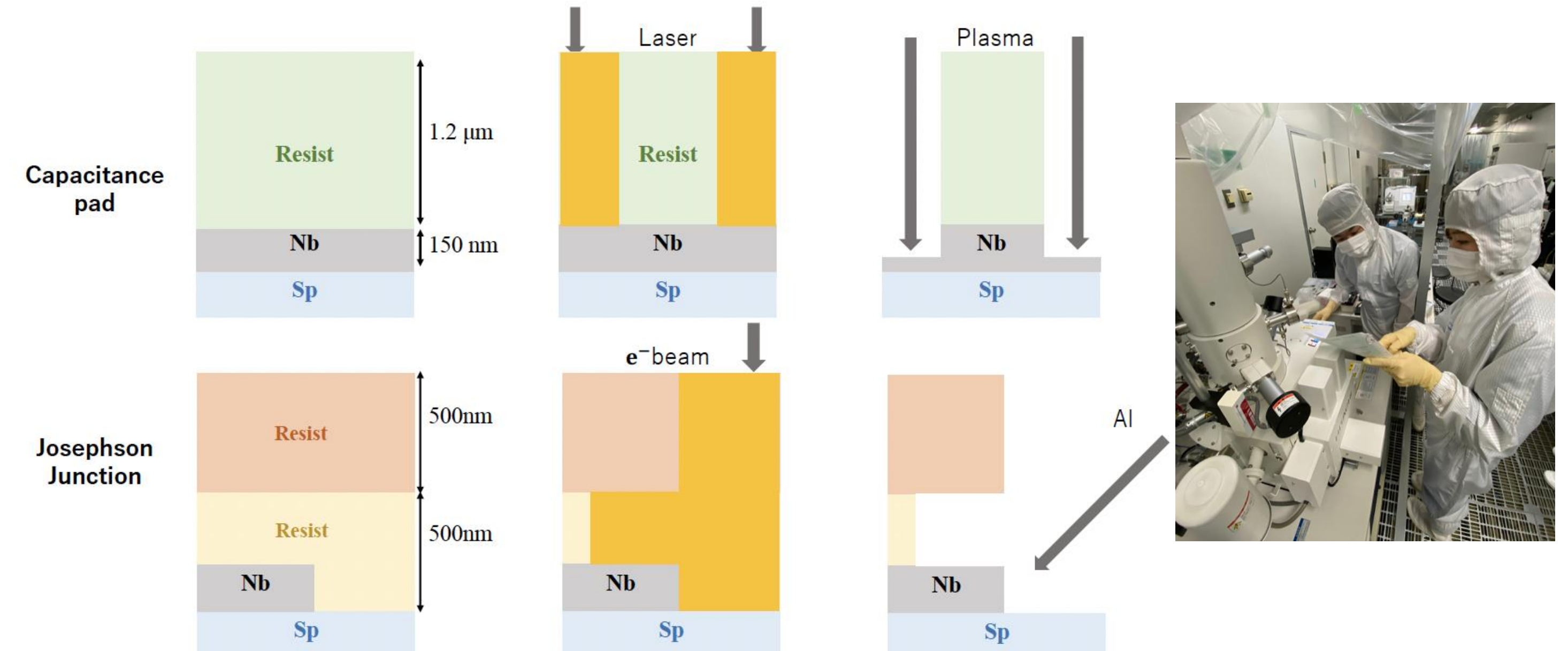

Preliminary Results & Outlook

Results from 2 qubits: standard (Qubit A) & SQUID-based (Qubit B)

tuned by AC stark shift tuned by SQUID

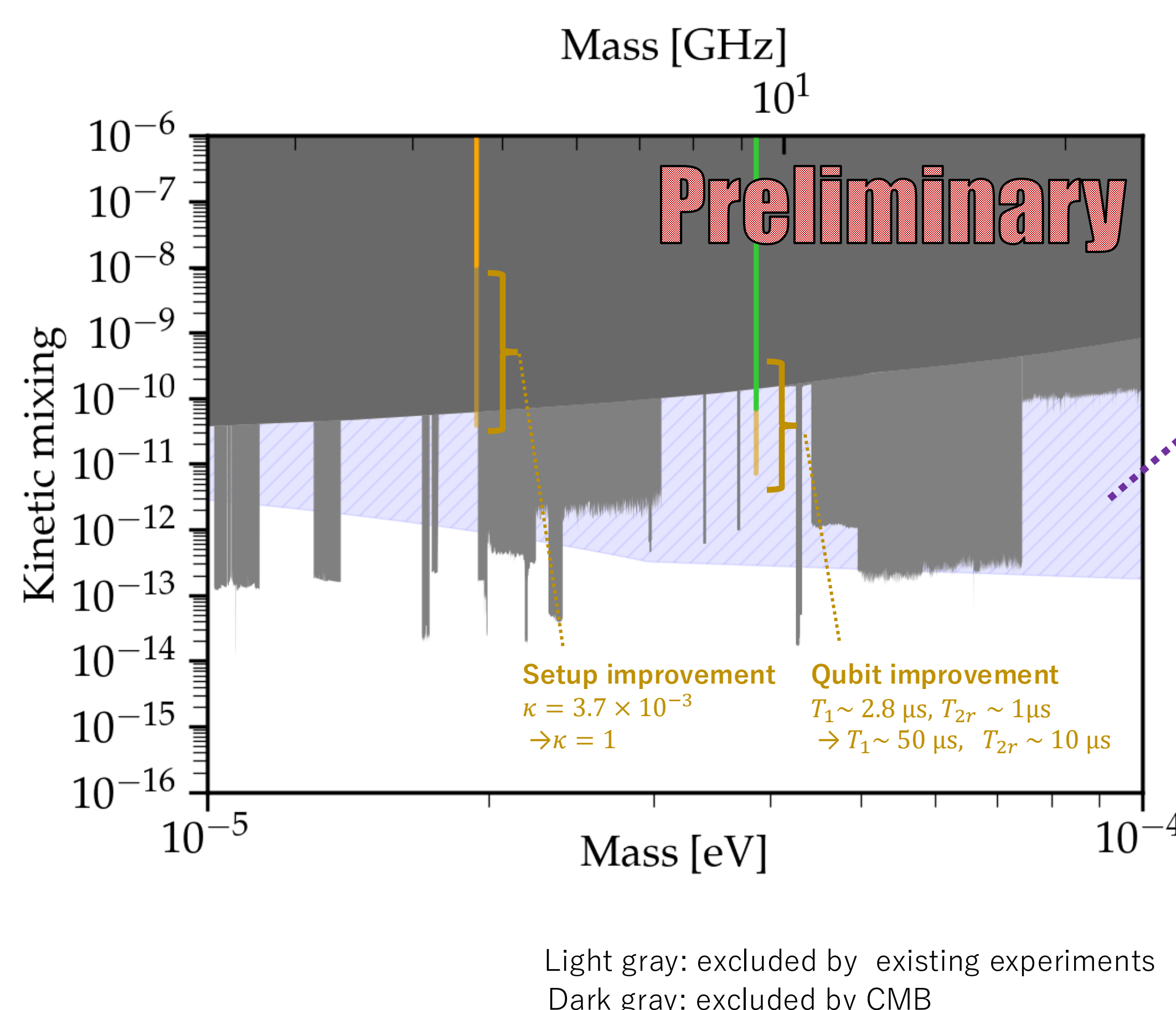
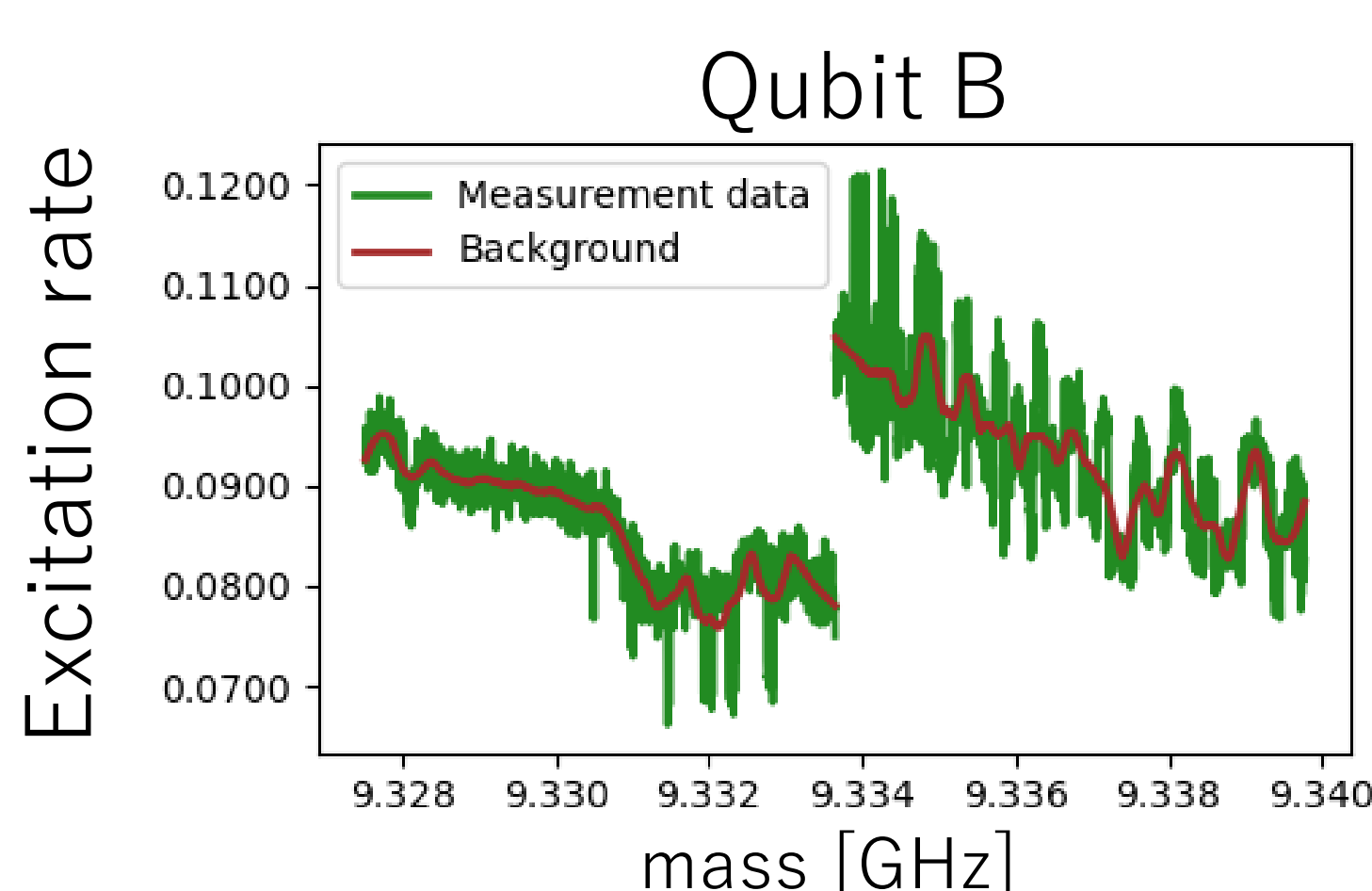
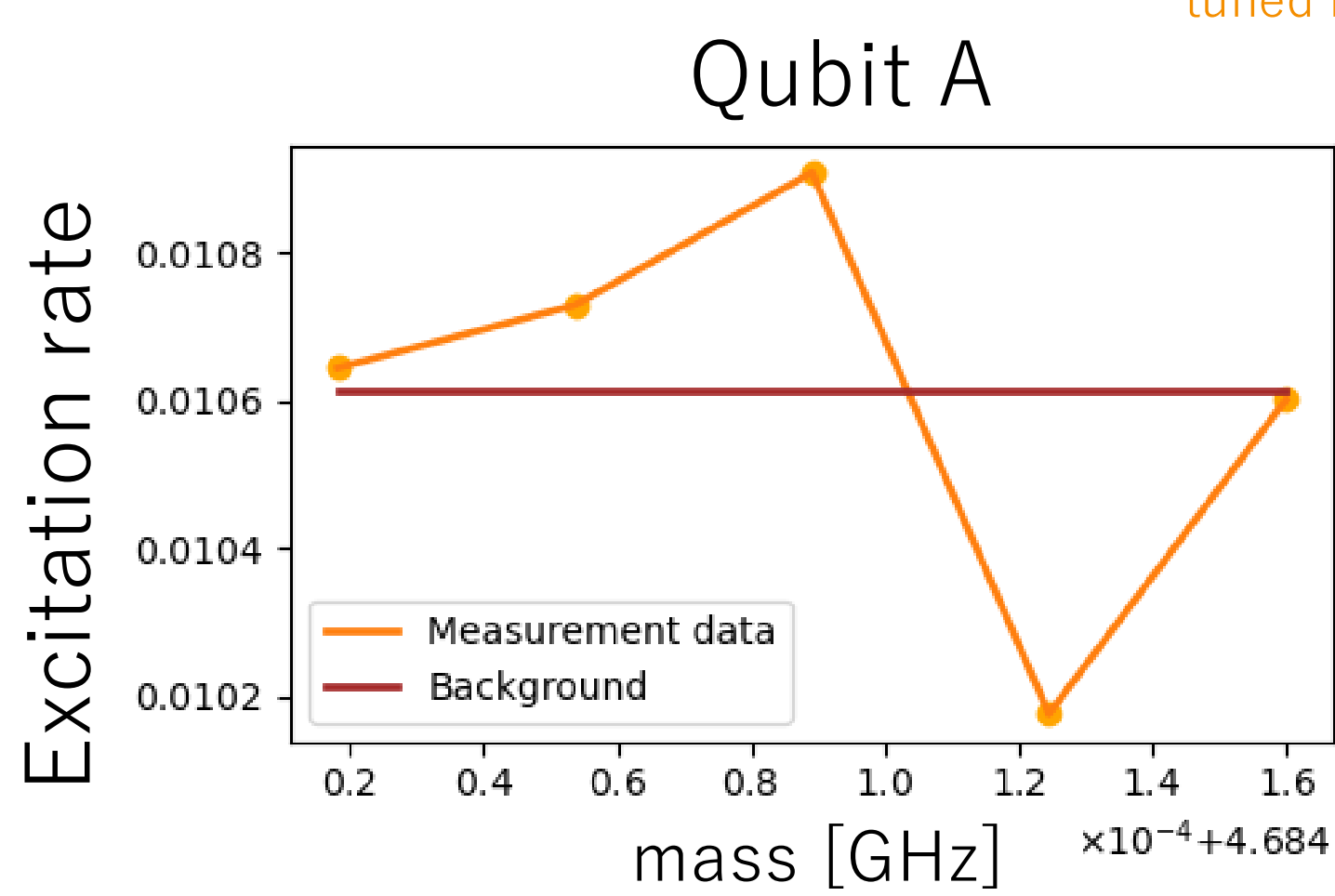

- There was no peak ($> 5\sigma$) from **4.684018 to 4.684160 GHz** & from **9.3275 to 9.3398 GHz**
 \rightarrow suggest no dark photons in these freq. ranges

• Future exploration area by this method

- Design optimization for the search while standard transmons are used so far
- large capacitance pads ($C \sim 0.1 \text{ pF}$)
- long distance btw pads ($d \sim 100 \mu\text{m}$)
- High-frequency qubit

- This method can be applied to **axion** search
Chen+, arXiv:2407.19755 convert into E-field UNDER B-field