

Solar Axion Search by ^{57}Fe Target TES Microcalorimeters with MW-multiplexed Readout

Axion

CP symmetry can be naturally violated from the definition, however it's conserved in reality. (\leftrightarrow n-EDM is not observed)

This is called the **strong CP problem**. Axion is elementary particle which is introduced for a solution to the strong CP problem.

Characteristics of Axion:

- charge 0, spin 0, pseudo-scalar boson
- small mass, < 1 keV from cosmological limit
- extremely weakly couples with SM particle
- candidate of dark matter (DM)
- similar particles expected from string theory

Coupling with photon : $\mathcal{L}_{a\gamma\gamma} = -\frac{g_{a\gamma\gamma}}{4} a F_{\mu\nu} \tilde{F}^{\mu\nu} = g_{a\gamma\gamma} a \mathbf{E} \cdot \mathbf{B}$

Coupling with fermions : $\mathcal{L}_{aff} = \frac{C_f}{f_a} \partial_\mu a \bar{\psi}_f \gamma^\mu \gamma_5 \psi_f$

Solar Axion

If the axion exist, the Sun is strong source of axions.

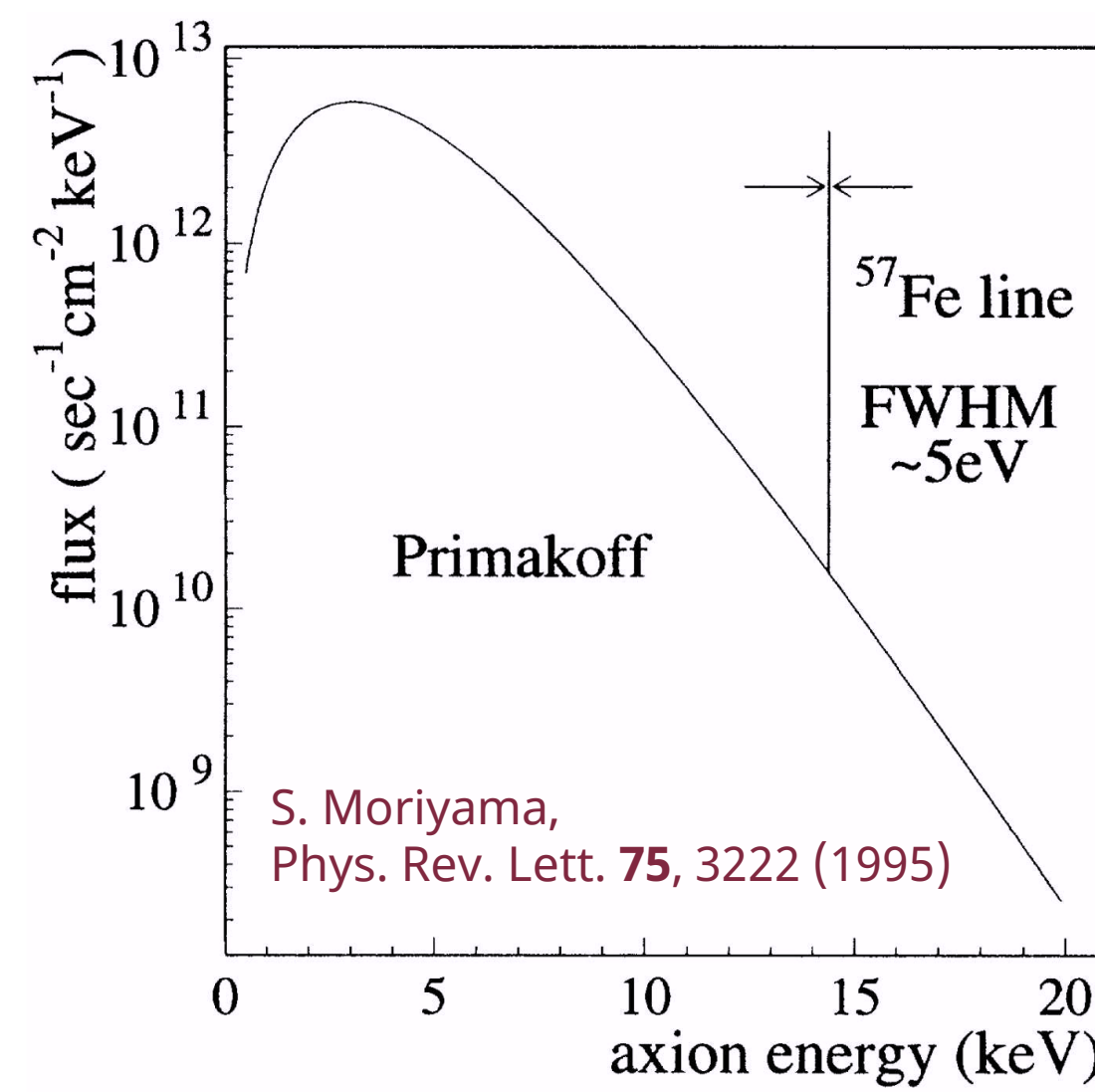

Primakoff effect: Axion is converted into photon by magnetic field (in atom) Continuous spectrum

^{57}Fe :

Axion is emitted from deexcitation of M1 transition of ^{57}Fe nucleus. 14.4 keV monochromatic $\pm 5\text{eV}$ by Doppler broadening

Effective Lagrangian $\mathcal{L}_{aN} = -ia\bar{N}\gamma_5(g_{aN}^0 + g_{aN}^3\tau^3)N, N = (p, n)^T$

Axion search

Many experiments limits the coupling of axion. (coupling with photon shown here)

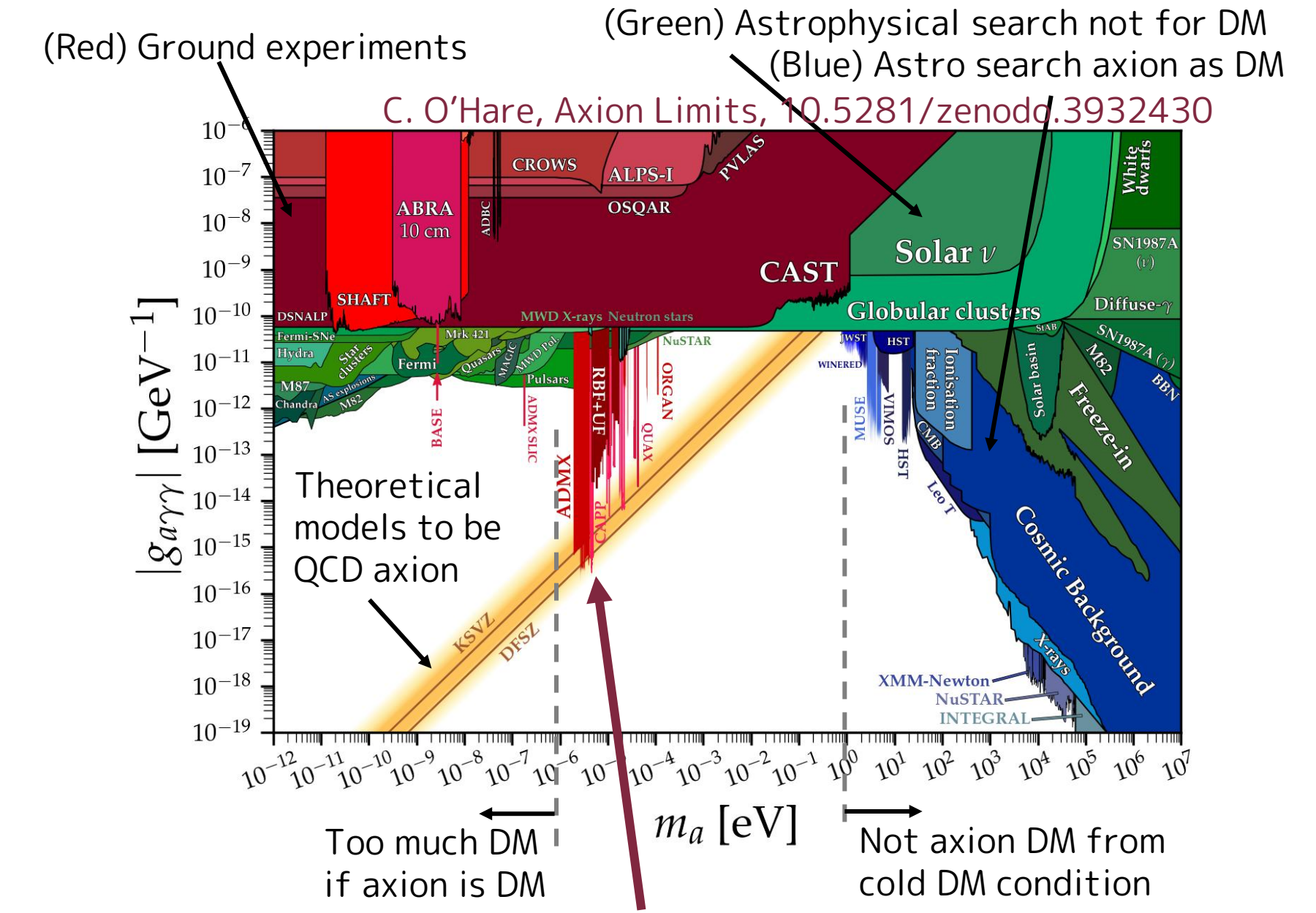

Cavity experiments start to search where QCD axion can be major component of dark matter in ΛCDM model.

Concept of this experiment

Search solar axion from ^{57}Fe nuclei, by converting with ^{57}Fe into 14.4 keV photon, and detect it with TES microcalorimeter

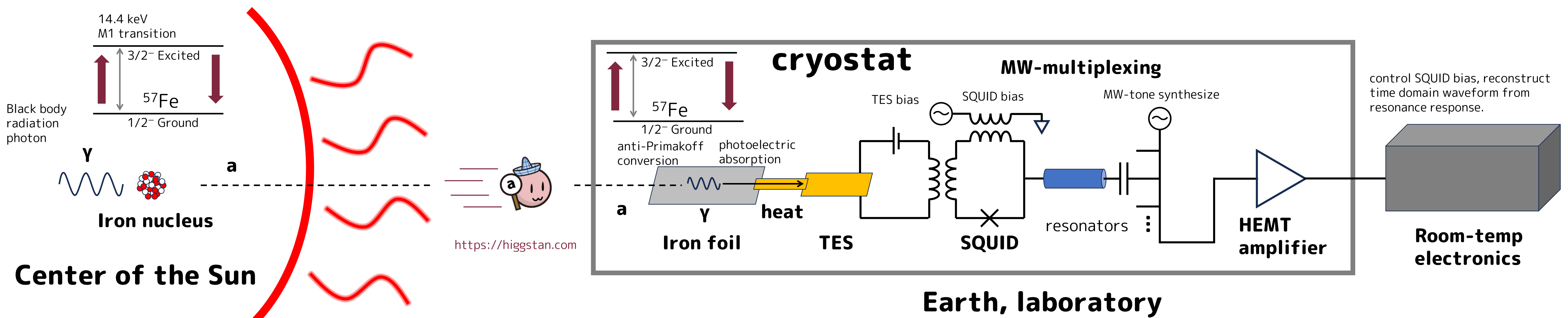

Detector

Transition Edge Sensor (TES) microcalorimeter

TES is high-sensitivity thermometer which utilizes the sharp edge of superconducting transition.

Detector for this experiment is designed and manufactured in JAXA nanotech facility.

As Fe is ferromagnetic material, target pad put apart from TES and connected with Au strap.

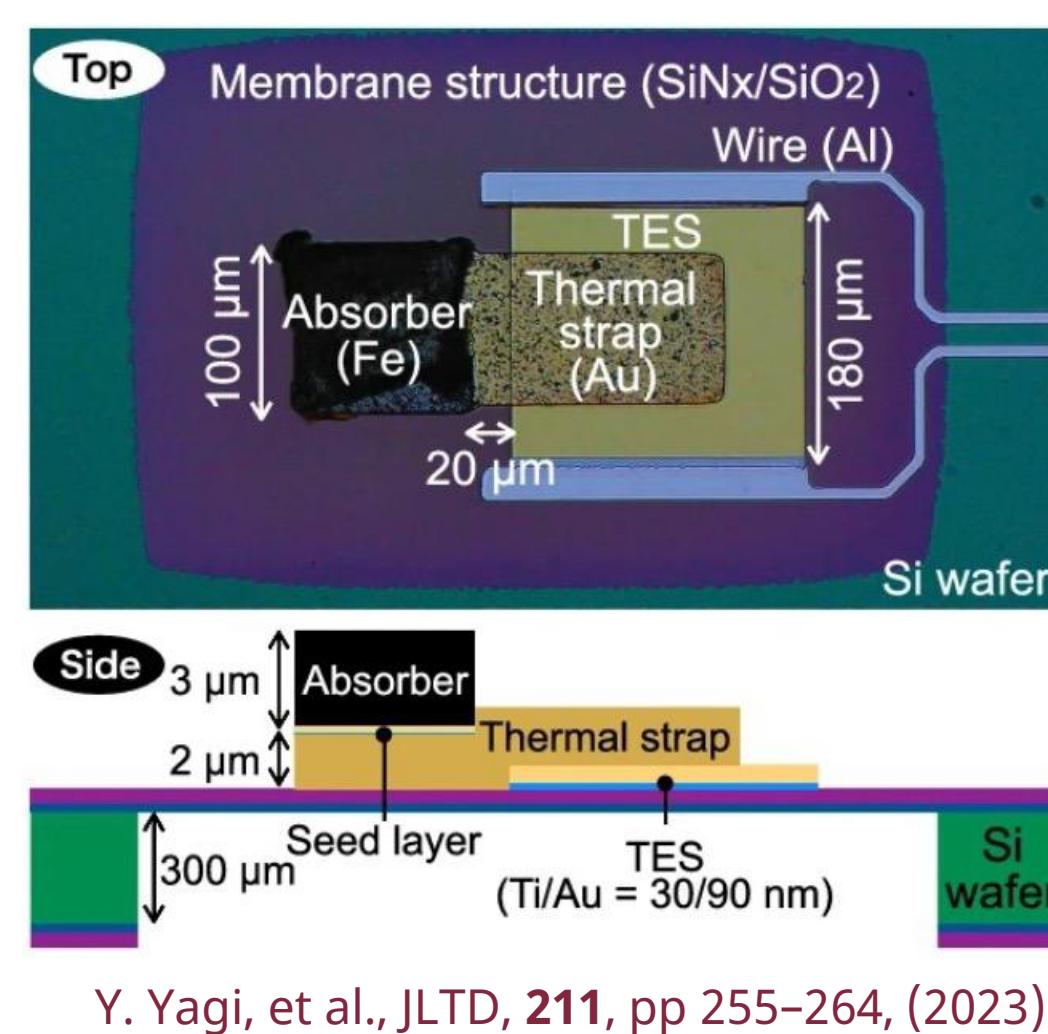
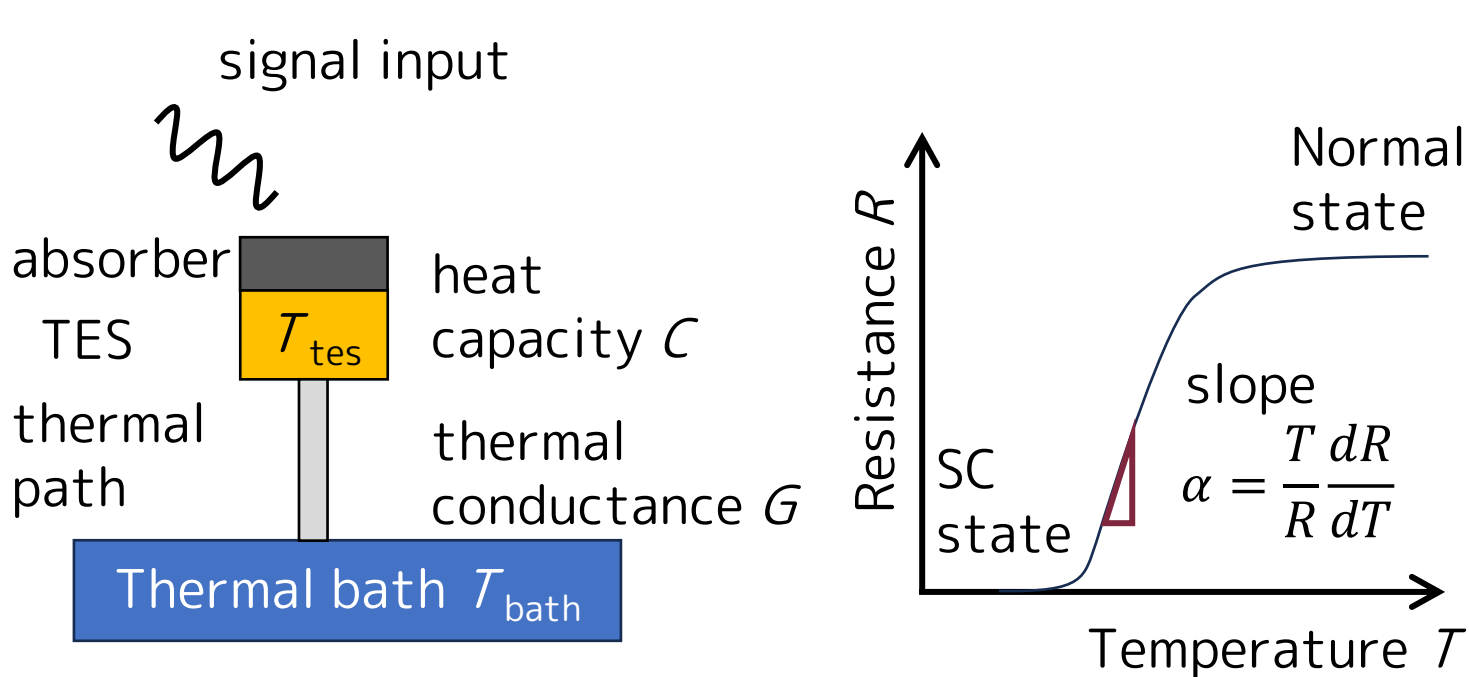

Energy resolution $\Delta E \propto \sqrt{\frac{CT_{tes}^2}{\alpha}}$

Y. Yagi, et al., JLT, 211, pp 255-264, (2023)

Readout

MicroWave-multiplex (MW-mux) is adopted

To operate multiple detector channels in cryostat, multiplexing is required to avoid too much heat inlet from readout cables.

The time domain data is derived from the change of phase by change of SQUID output. GHz range is needed to achieve higher sampling ratio.

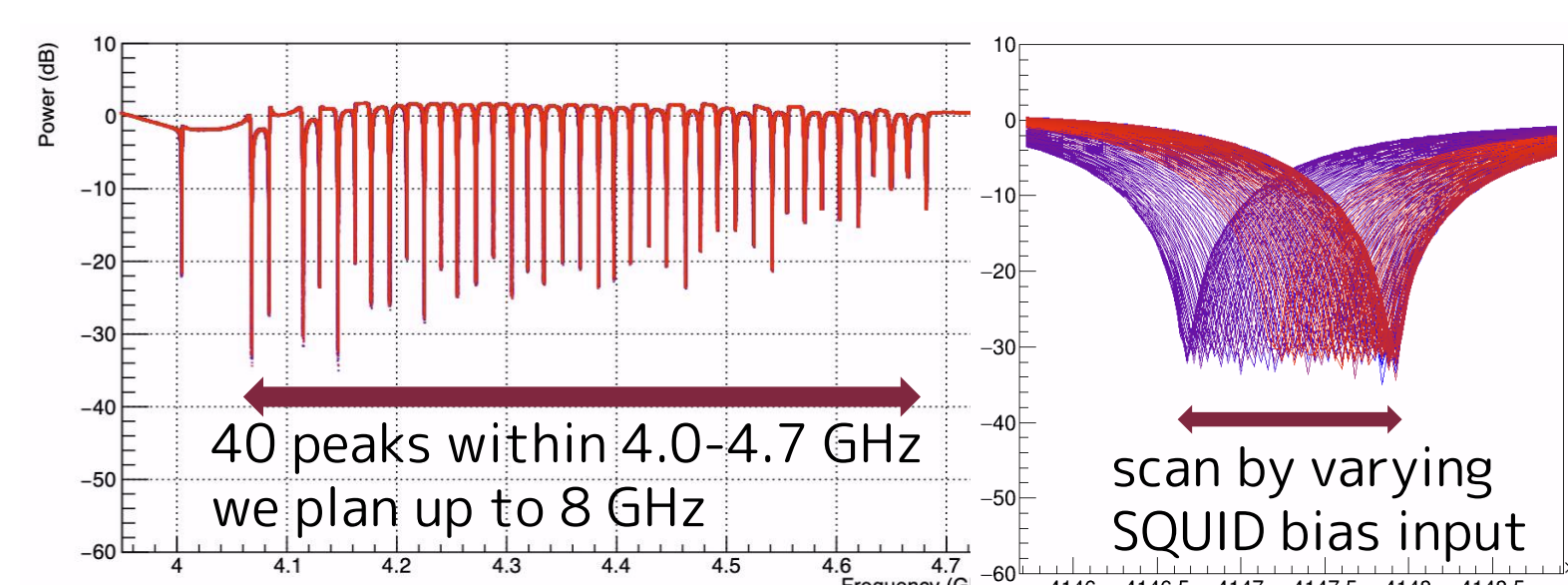

Example of resonators peaks and its shift by SQUID ramp wave. Fabrication and characterization is done at AIST.

Sensitivity prospect

Proposed experiment has advantage to previous ones, because with TES any power dissipation in absorber can be detected, this improves sensitivity.

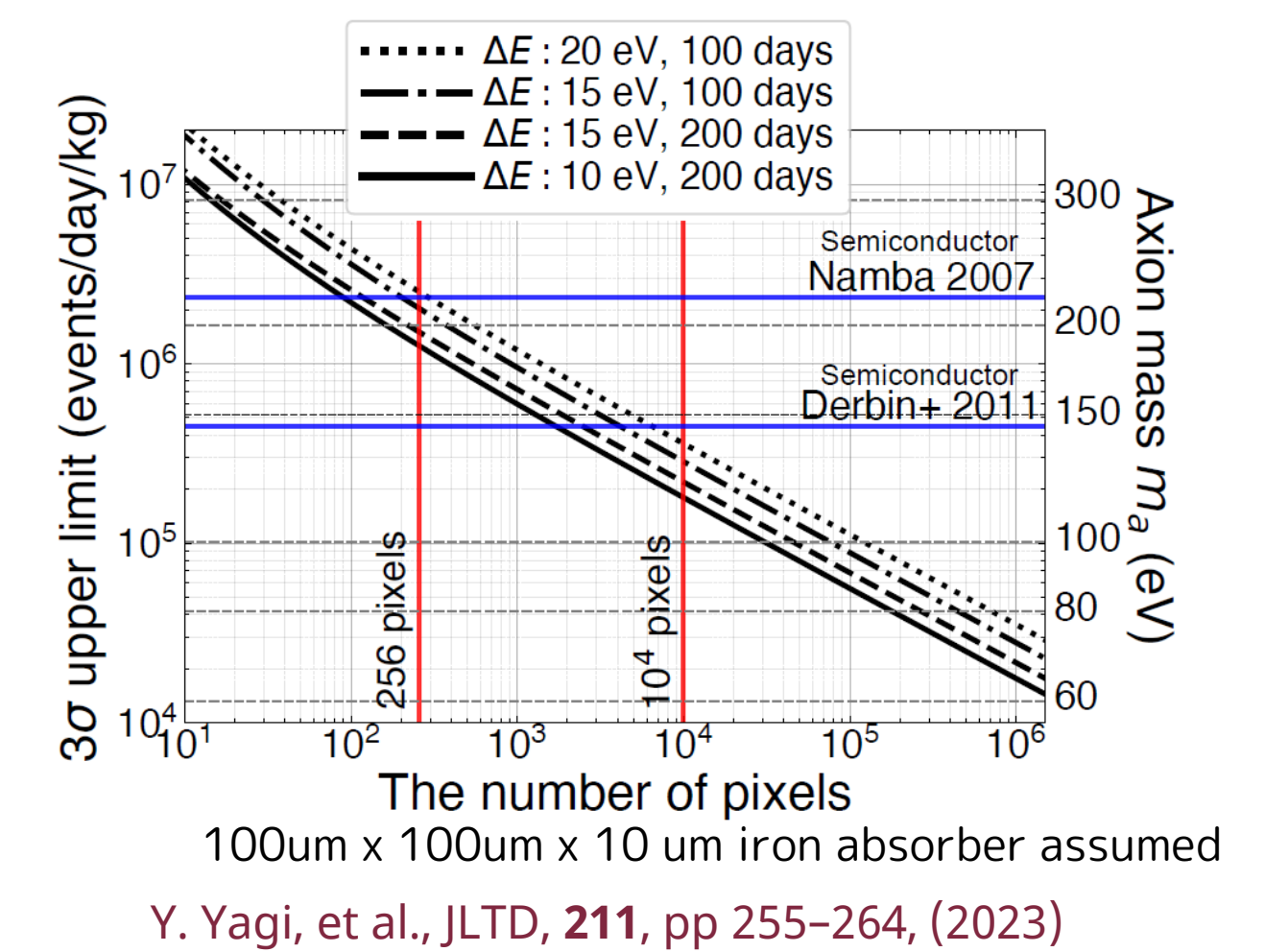

Bluefors LD400 dilution refrigerator

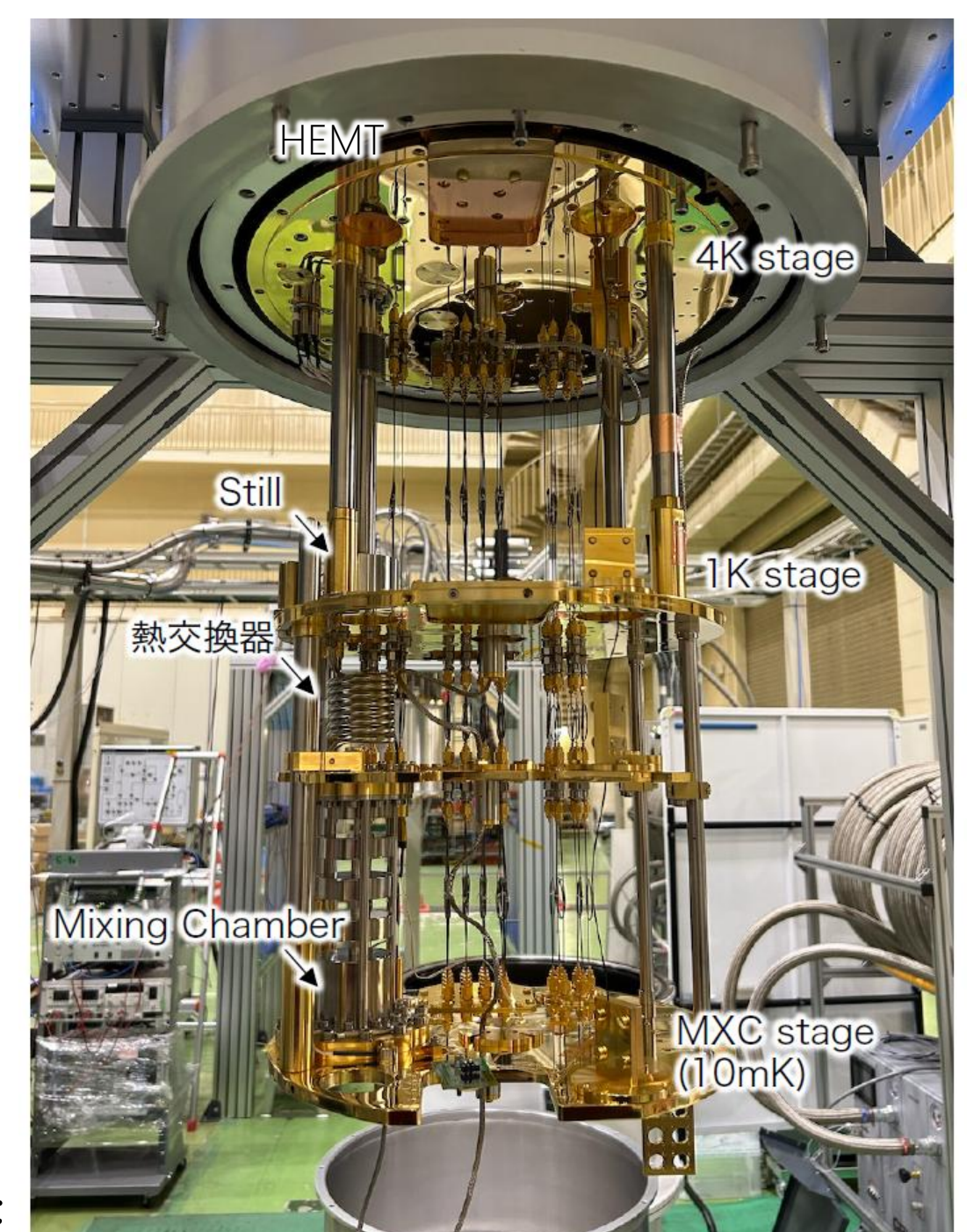

Room-temp readout electronics developed at AIST

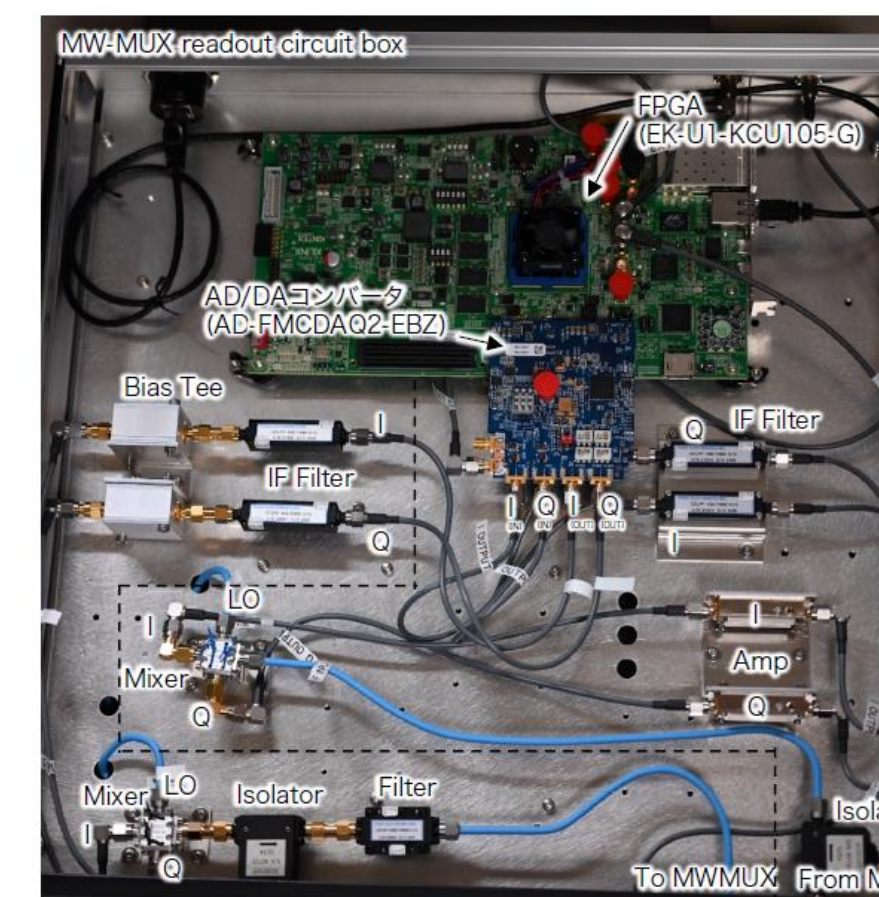

Cabling diagram inside cryostat

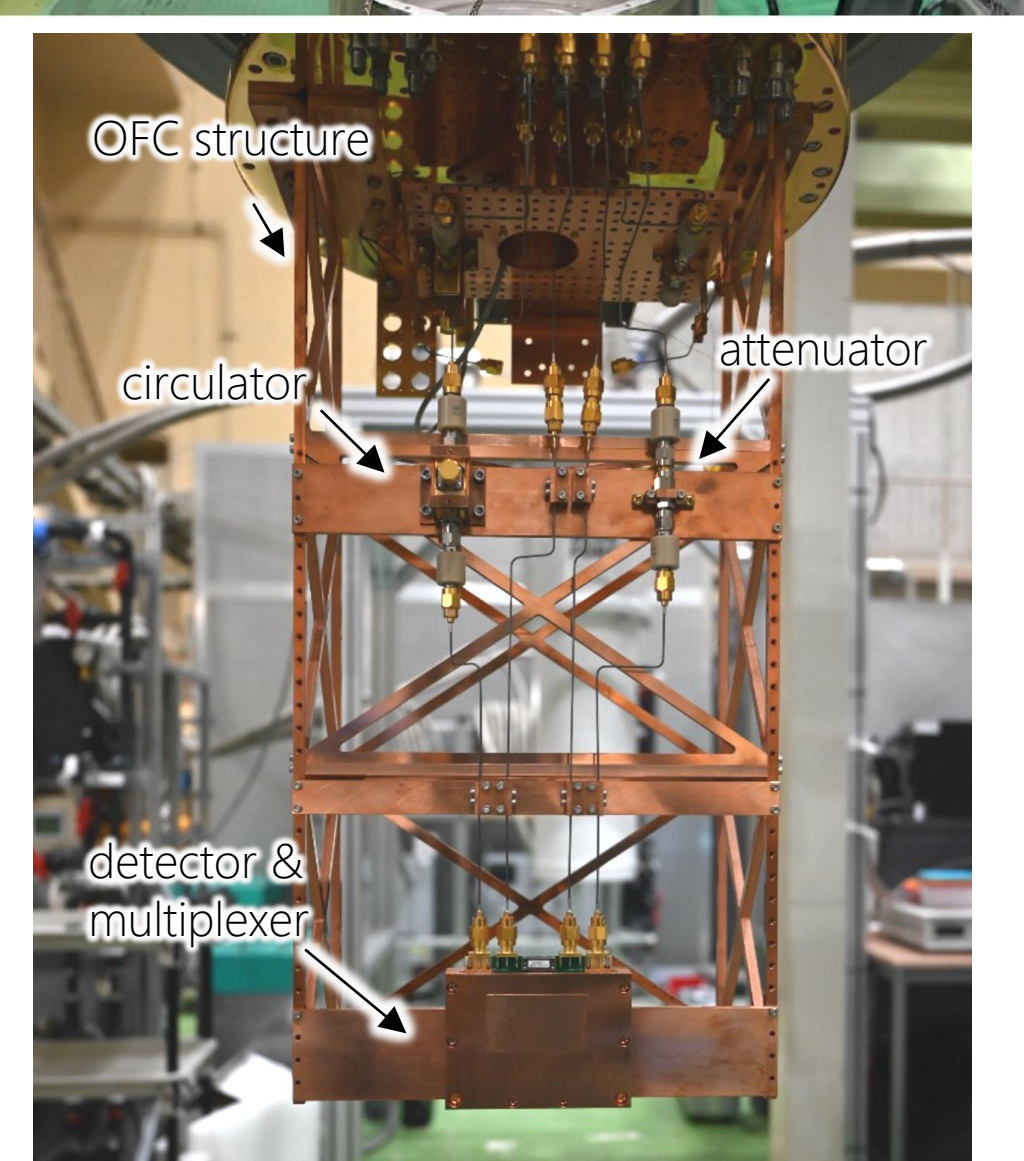
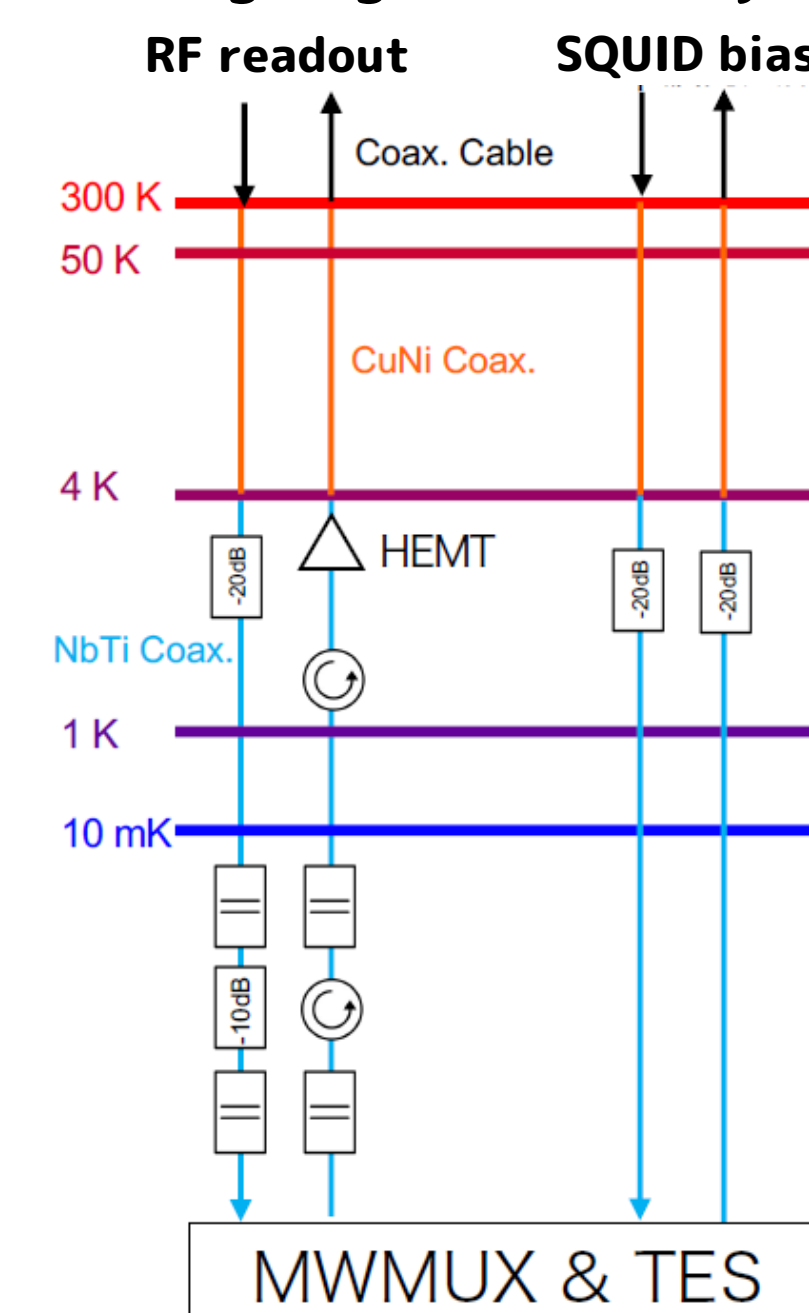

Fab. and Test at JAXA

Figures/pictures by Y. Yagi

In year 2024, detector with 64 channels designed for solar axion, is designed and fabricated at JAXA.

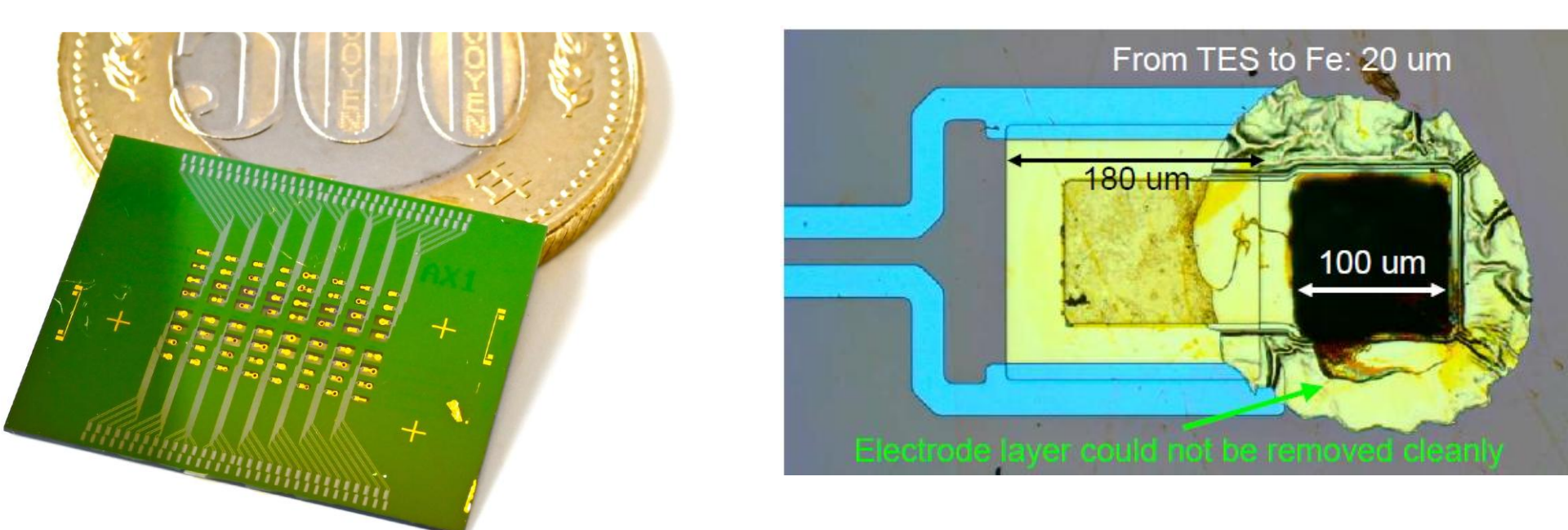

The operation and performance was tested at JAXA laboratory with single TES channel.

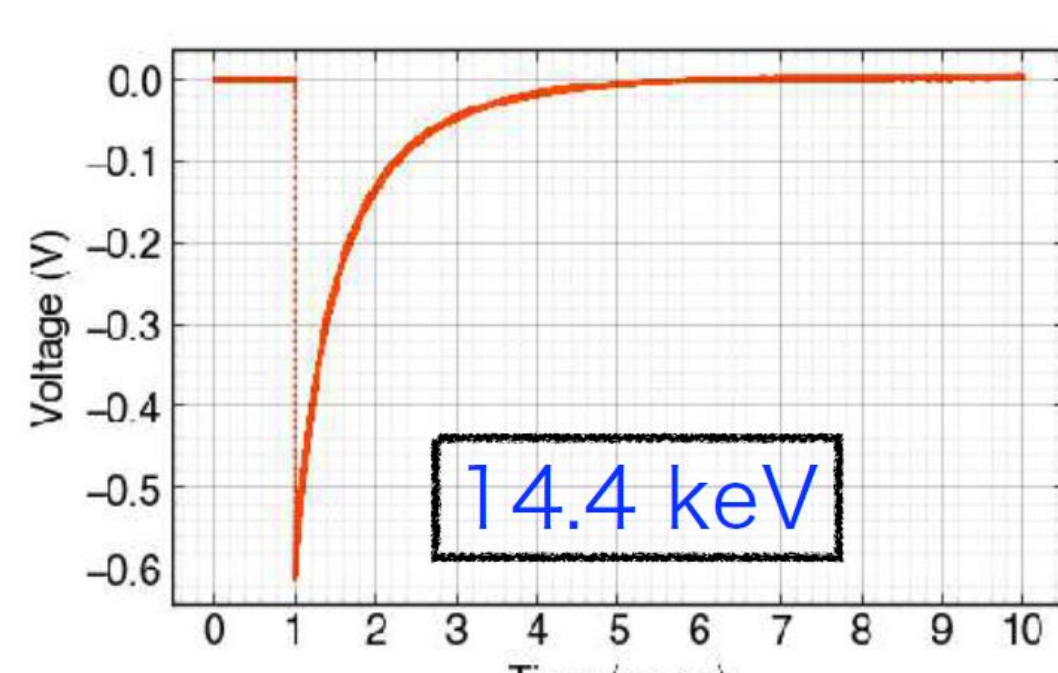

Example of 14.4 keV signal waveform.

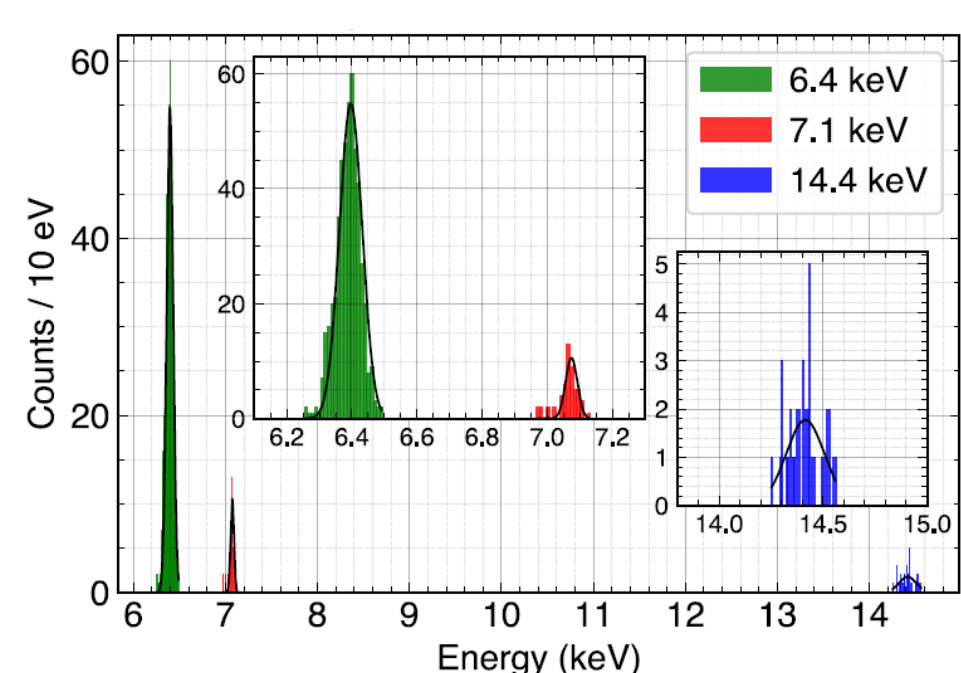

Energy resolution was estimated.

KEK QUP lab. facility

Figures/pictures by T. Ikeda

At B4 floor of Fuji hall. We are setting up experiment apparatus in the dilution refrigerator.

In fiscal year 2024, we performed

- cabling and component arrangement inside of the cryostat
- cooling test with component equipped
 - achieved < 20 mK
- Assembly of room-temp electronics
- Signal gain check with HEMT

In this fiscal year next items to be performed

- Test of room-temp electronics
- MW-mux readout test
- Integration test with TES
- Commissioning of all apparatus
- Scientific data taking