

# Development of a Target Protection System Based on Online Beam Diagnostics for MW Operation of the J-PARC Neutrino Beamline

NPN2026

The Hirosawa City Center (Mito)

05.26 - 5.28 (Day 2)

Ayana Asai, Yusuke Koshio, Ken Sakashita<sup>A</sup>, Yota Hino<sup>A</sup>  
Okayama Univ., KEK<sup>A</sup>

# Beam Power Upgrade for Hyper-K

- Hyper-Kamiokande: precision measurements of  $\nu$  oscillation, proton decay search, etc...
  - > Higher statistics are required
  - > Beam power upgrade @ J-PARC  $\nu$  beamline -> **1.3 MW (2028)**

$$\text{Beam power [W]} = \frac{\text{Proton energy [eV]} \times \text{Current [A]}}{\text{Repetition cycle [s]}}$$

$30 \text{ GeV}/c$        $\frac{\text{Number of protons} \times e}{\text{Repetition cycle [s]}}$

## Beam Structure

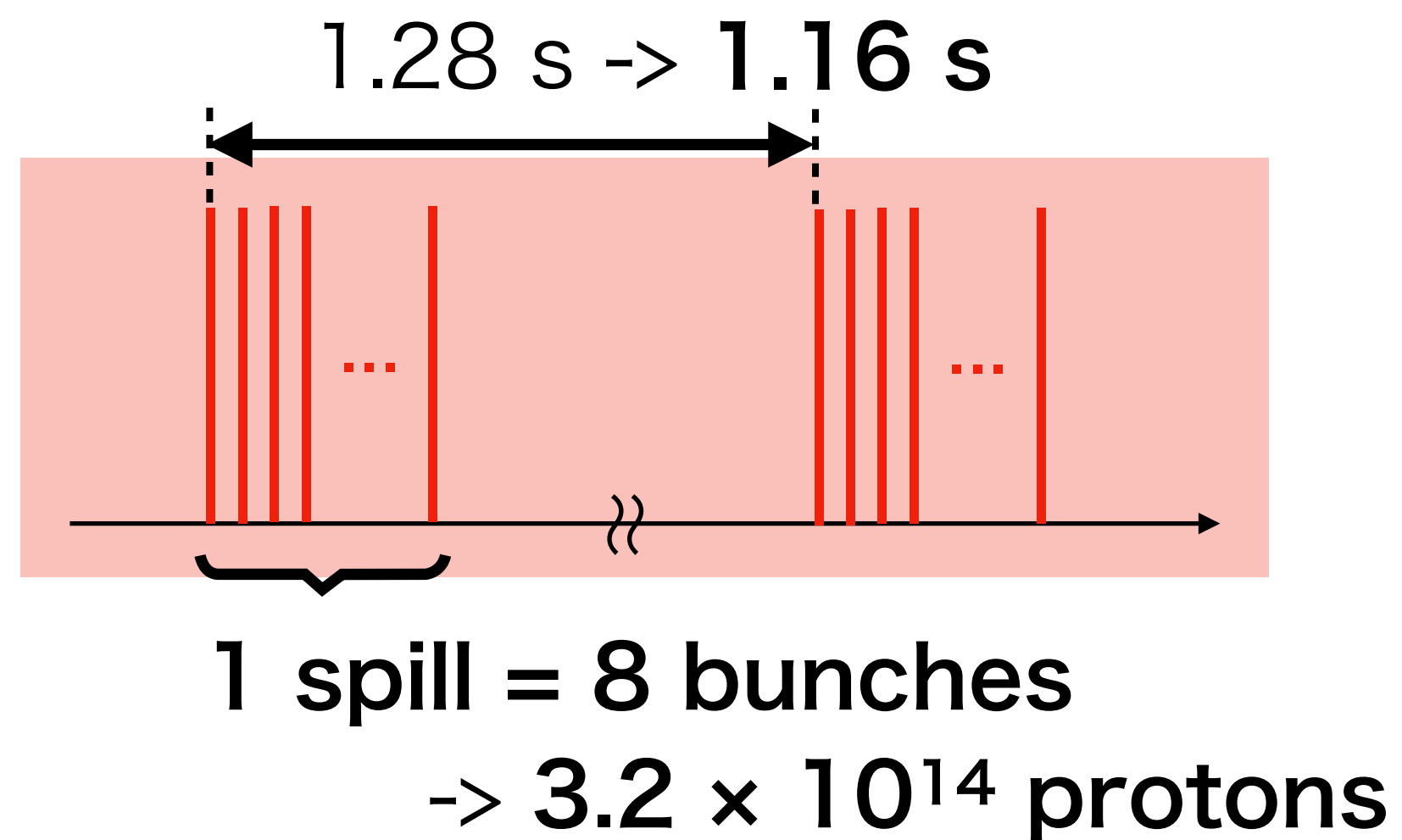

## J-PARC $\nu$ Beamline

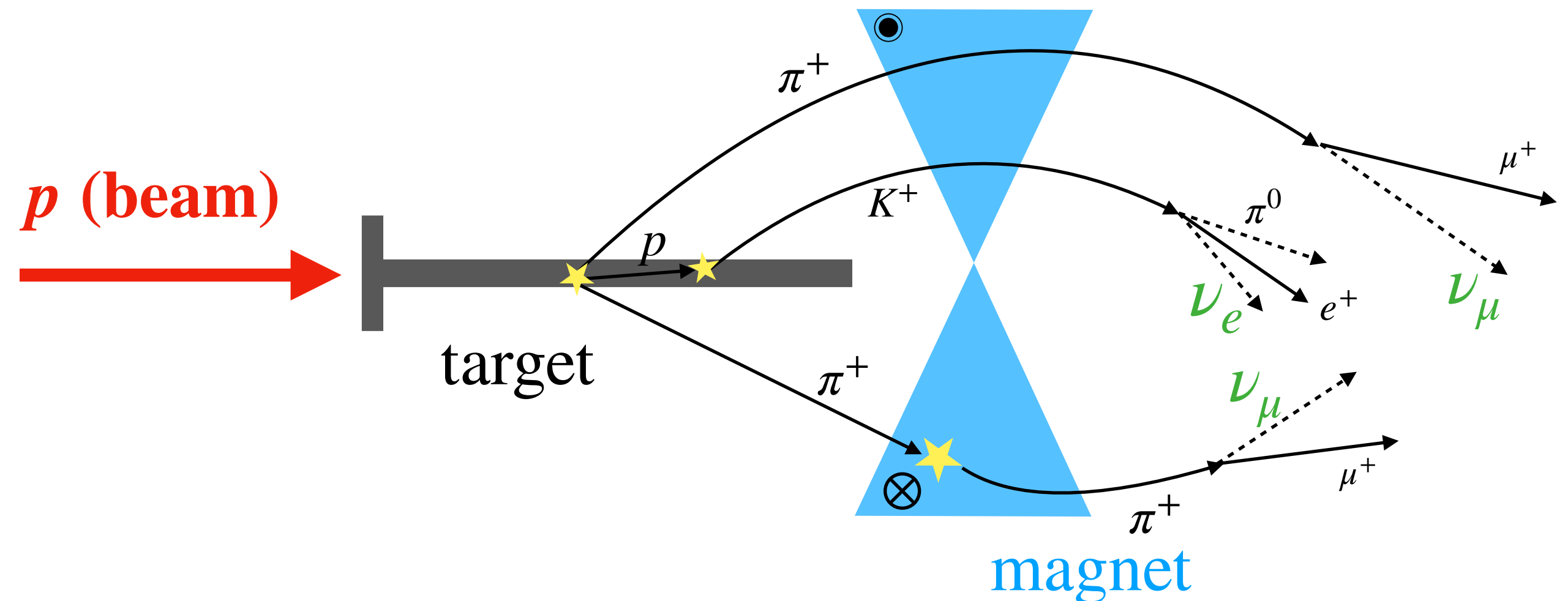

# Target Protection System

- Incorrect beam position or width can damage the target
  - > Monitor the **beam profile** continuously
- Current system: peak search and Gaussian fitting for each bunch (processing time: ~1 s)
  - > insufficient for future requirements (**1.16 s repetition cycle**)

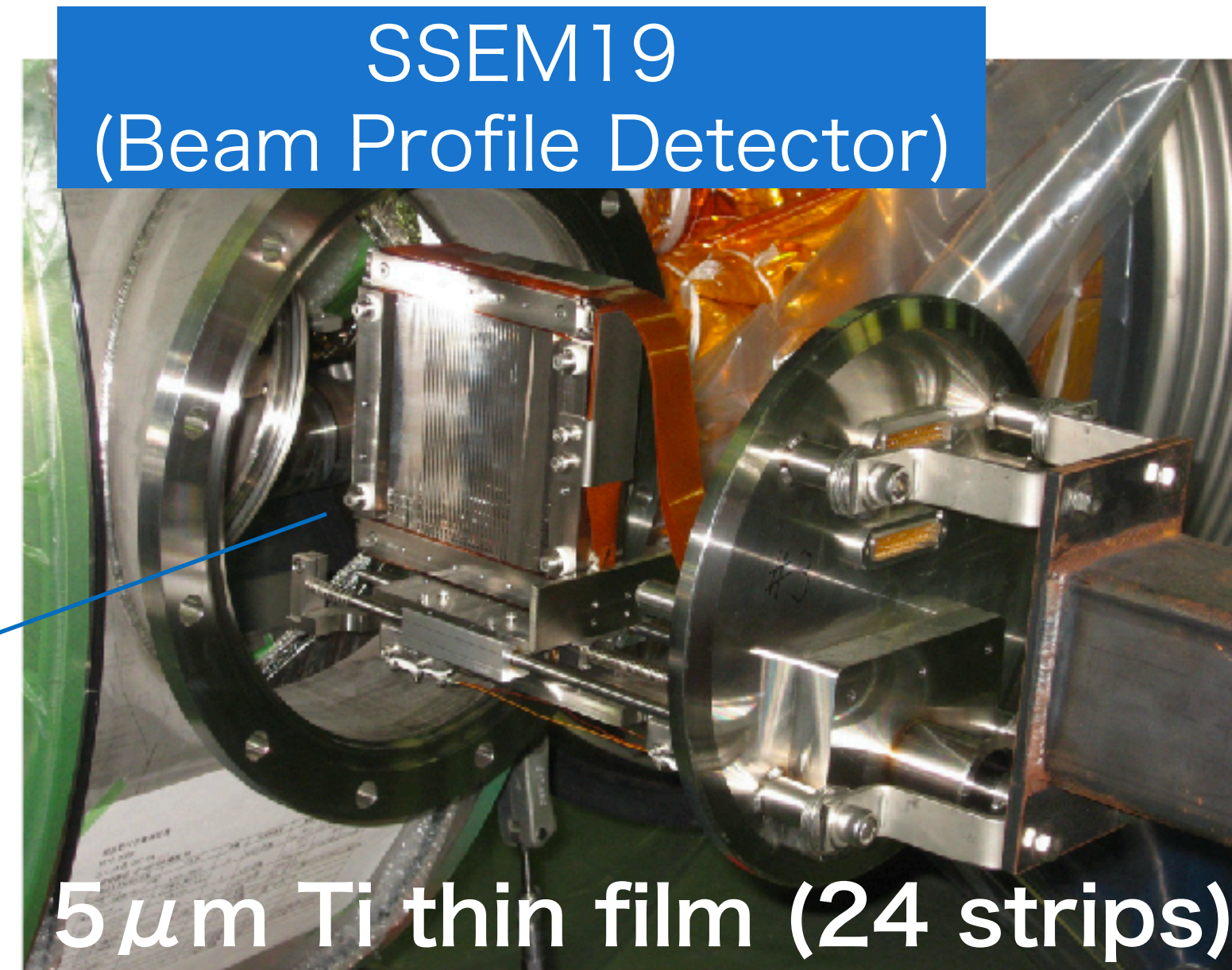

## Target Protection

p (beam)

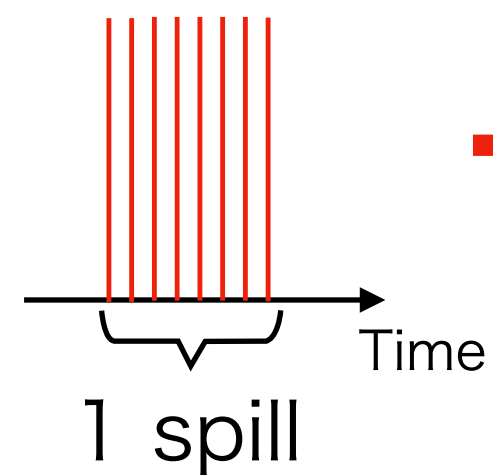

SSEM19

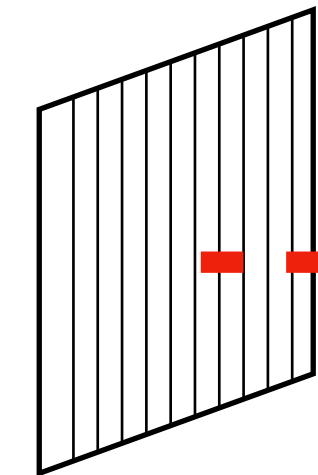

Carbon Target



Calculate Beam Profile

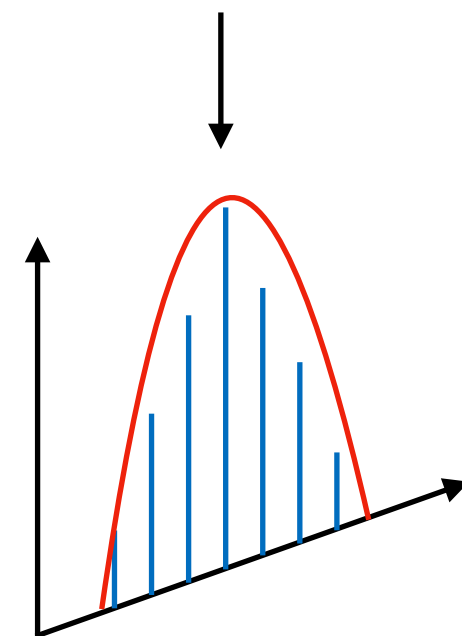

before the next spill is extracted

If the beam position or width is abnormal, an **interlock signal** is issued **immediately**

# Target Protection System

- Replace the offline calculation with a new **FPGA-based** method  
 -> Processing time is greatly reduced (**PAPILLON**)

## PAPILLON Calculation

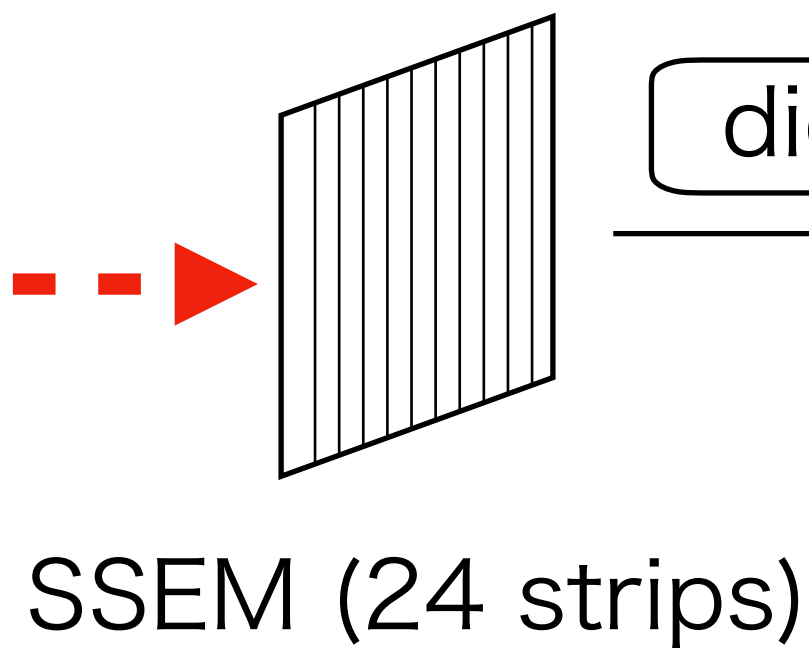

digitize signal

### Waveform (each strip)

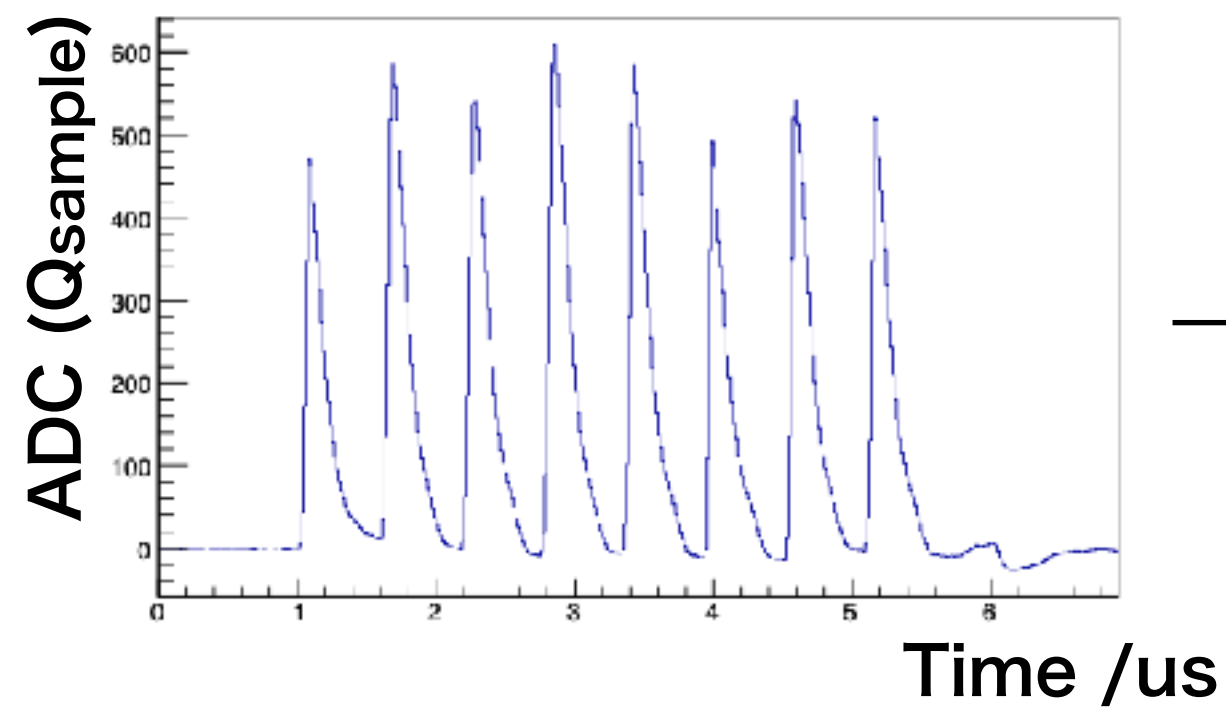

80 MHz × 8 us = 640 samples

ADC summation

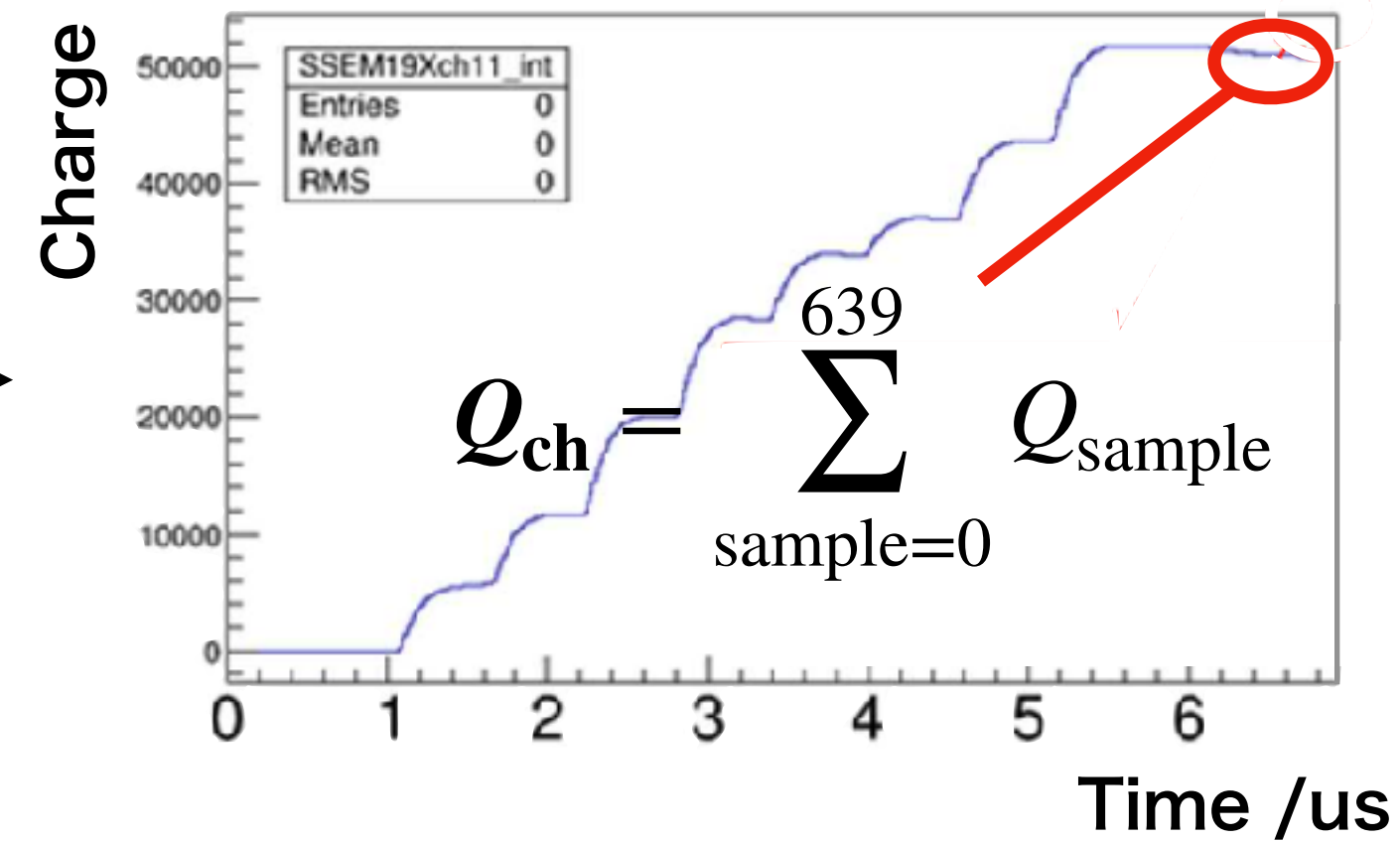

position:

$$X = \frac{\sum_{ch=0}^{23} Q_{ch} \times x}{\sum_{ch=0}^{23} Q_{ch}}$$

width:

$$\sigma_x = \sqrt{\frac{\sum_{ch=0}^{23} Q_{ch} (x_{ch} - X)^2}{\sum_{ch=0}^{23} Q_{ch}}}$$

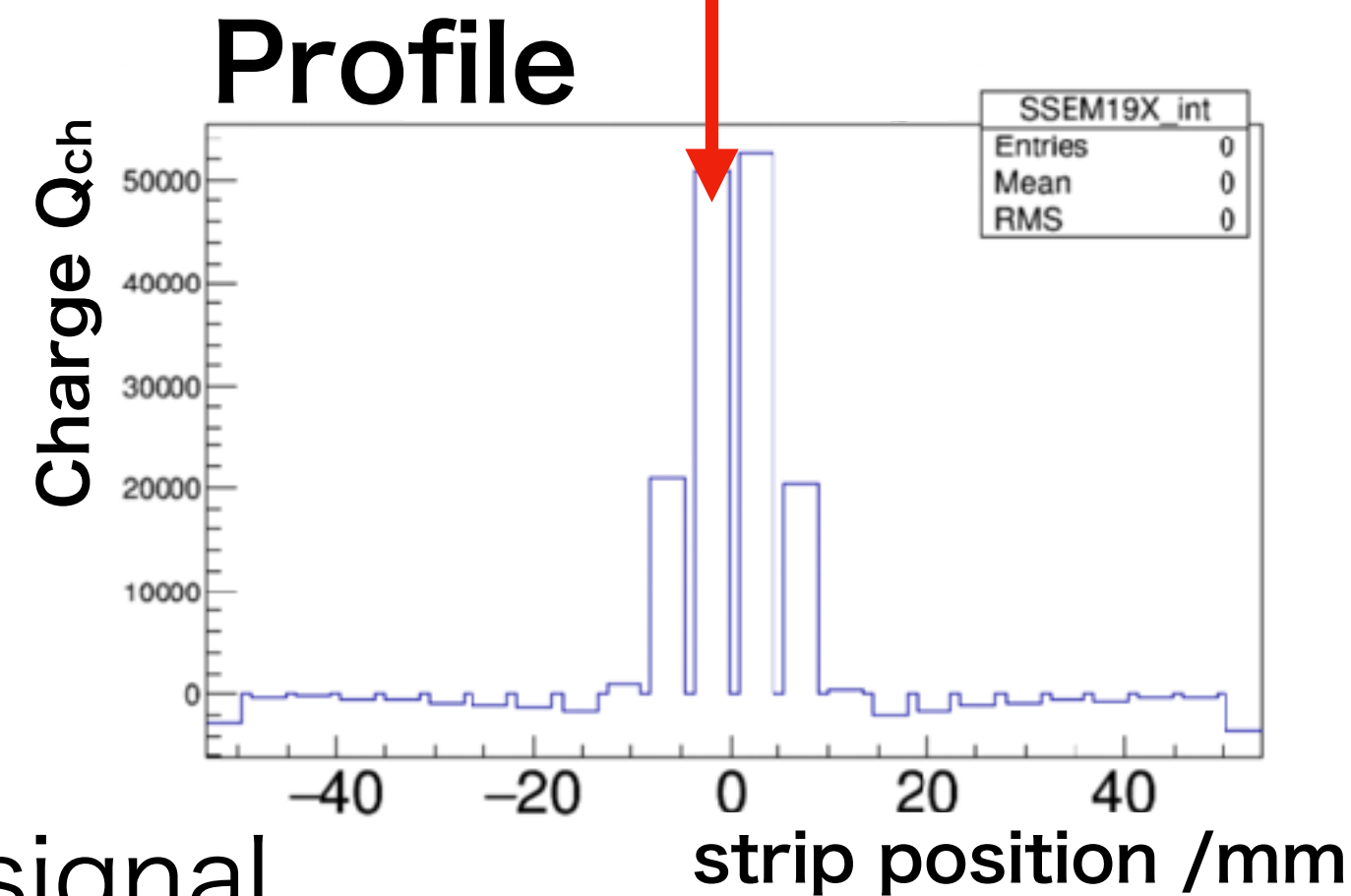

Strip selection  
 $Q_{ch} > 1200$

- If they **exceed threshold** -> issue **interlock** signal

# PAPILLON v3 Development

- v1 and v2 were previously developed
  - > Current version: **PAPILLON v3**
- Add a **second network** interface
  - For data transfer
  - For parameter control
- **Increase the ADC driver gain (~2x)**
  - To match the **COPPER** ADC amp.

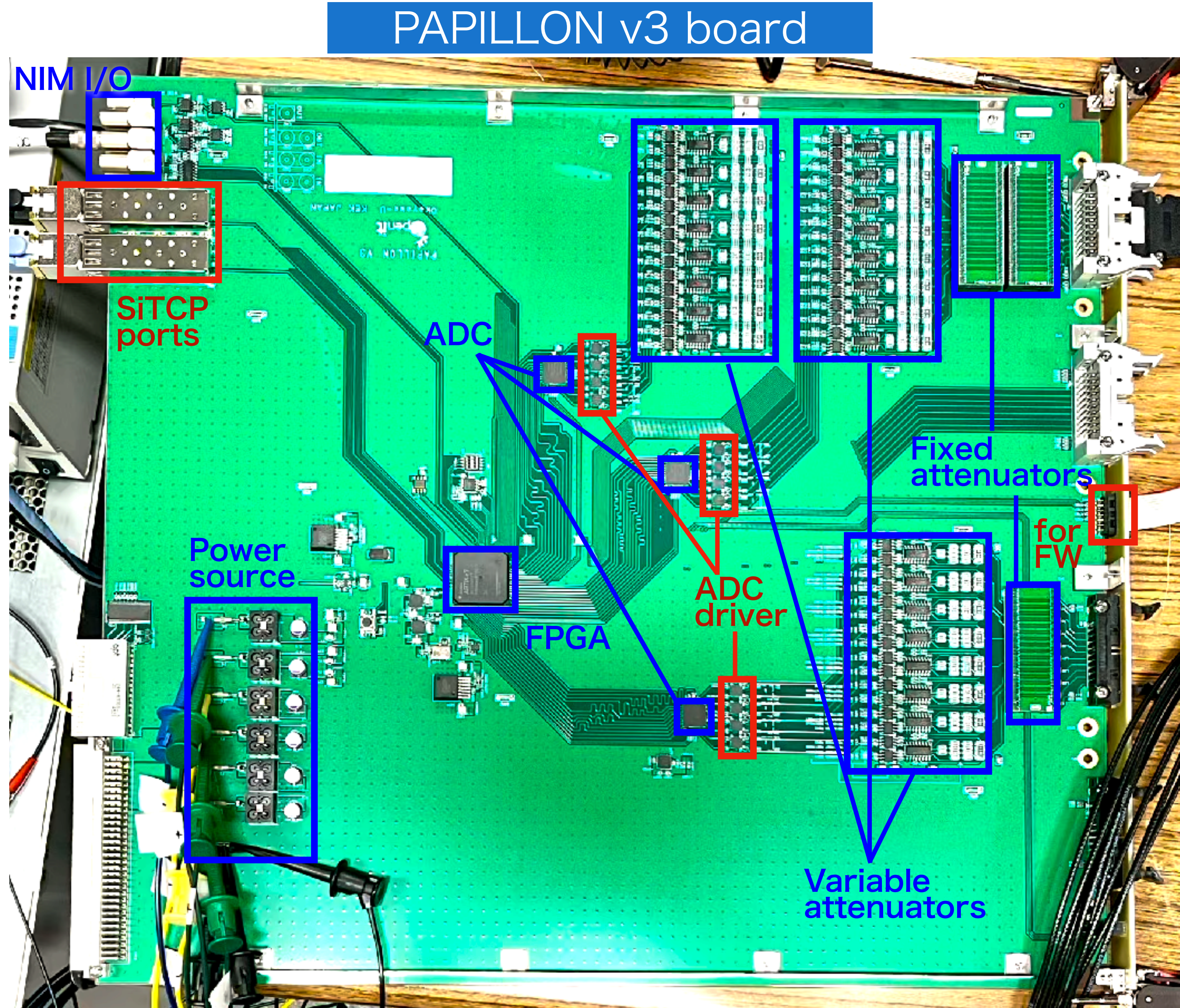
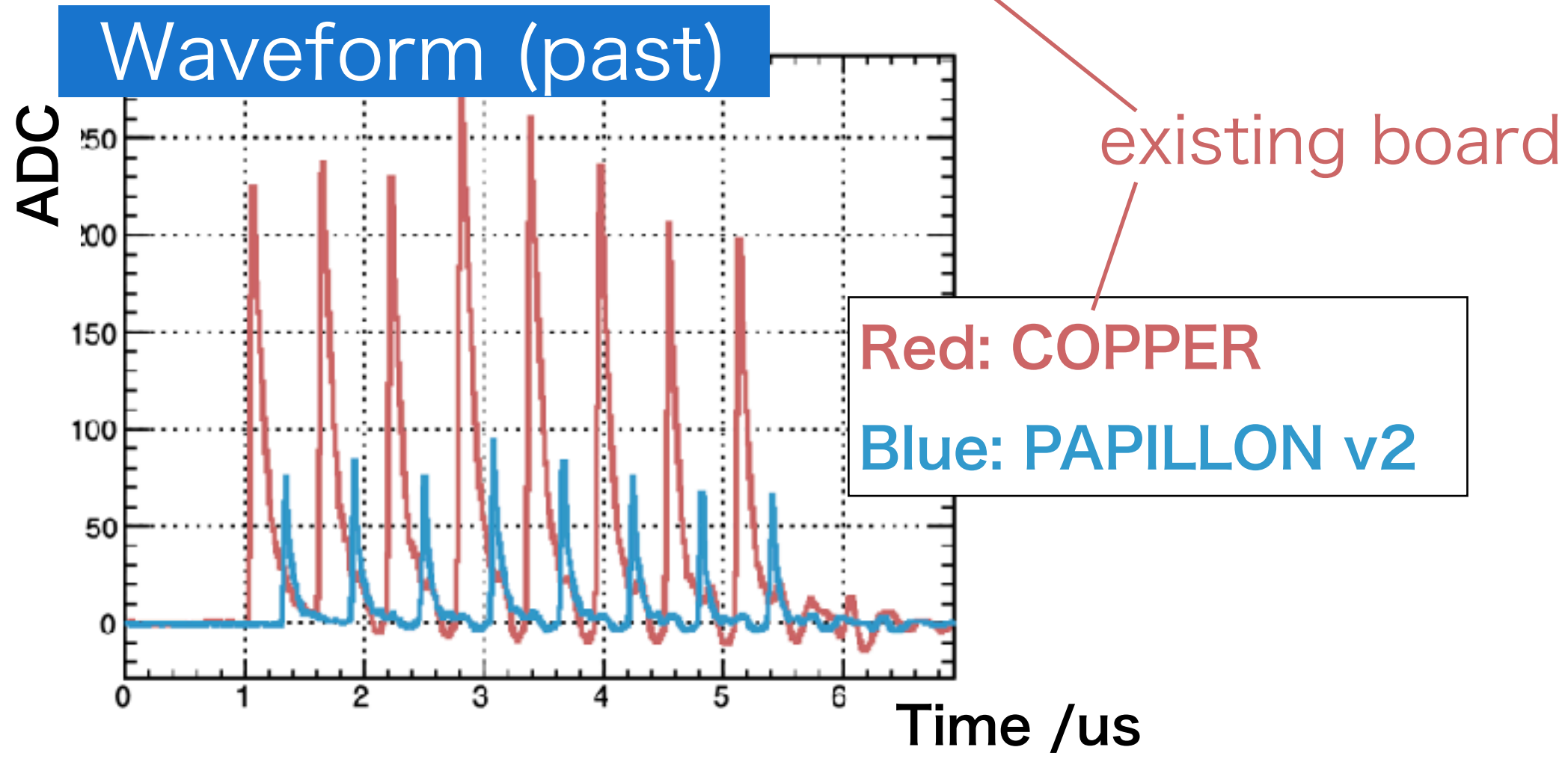

# PAPILLON v3 BeamTest (2026.03.11)

6

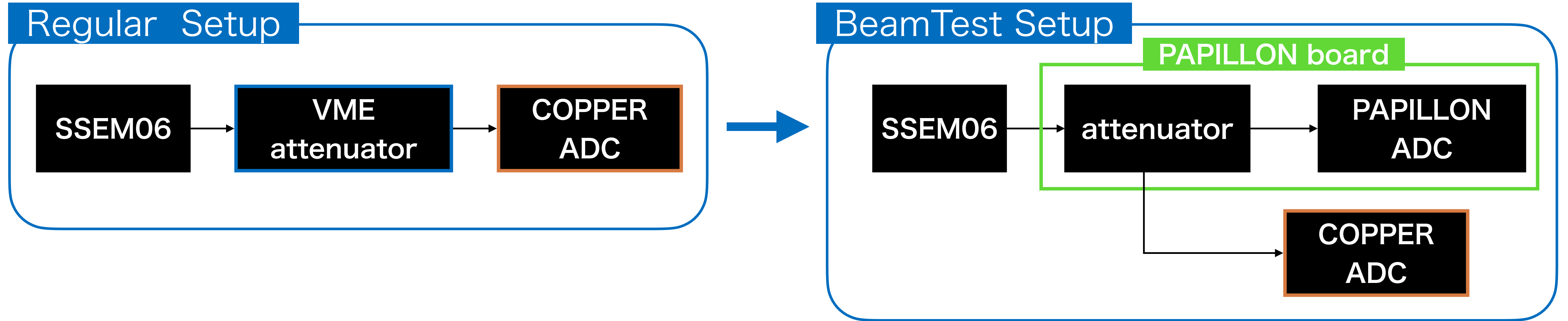

- **PAPILLON side:** PAPILLON ADC waveform -> position/width calculated on board by FPGA
- **COPPER side:** COPPER ADC waveform -> position/width calculated on PC (Gaussian fit)

## Frist beamtest with PAPILLON v3:

- Confirm waveform acquisition from SSEM06-X
- Validate PAPILLON v3 position/width calculation
- Compare with the T2K offline analysis results (= COPPER side)

# Waveform and Beam Profile

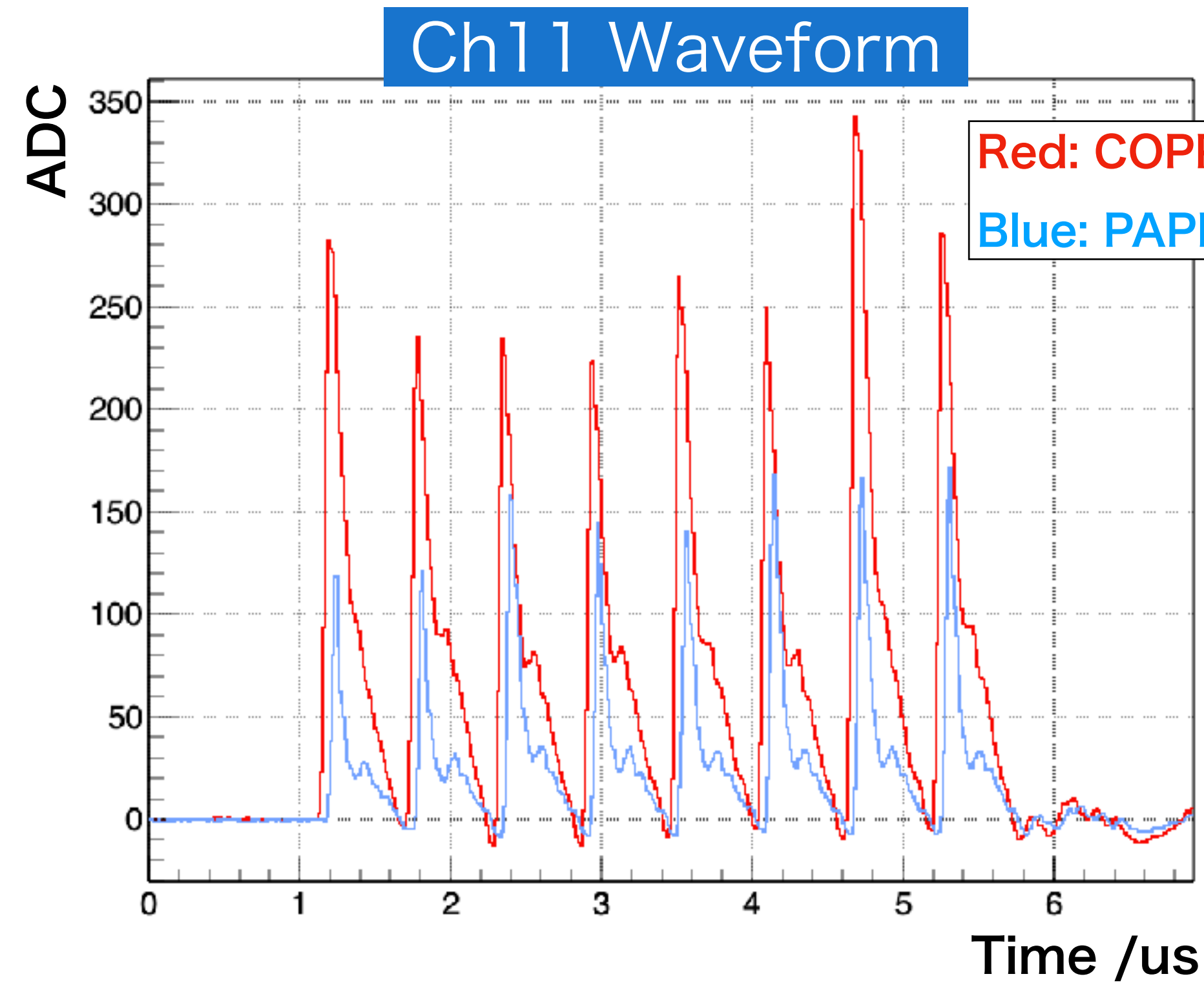

Integral (Summation)  
ADC count for each strip

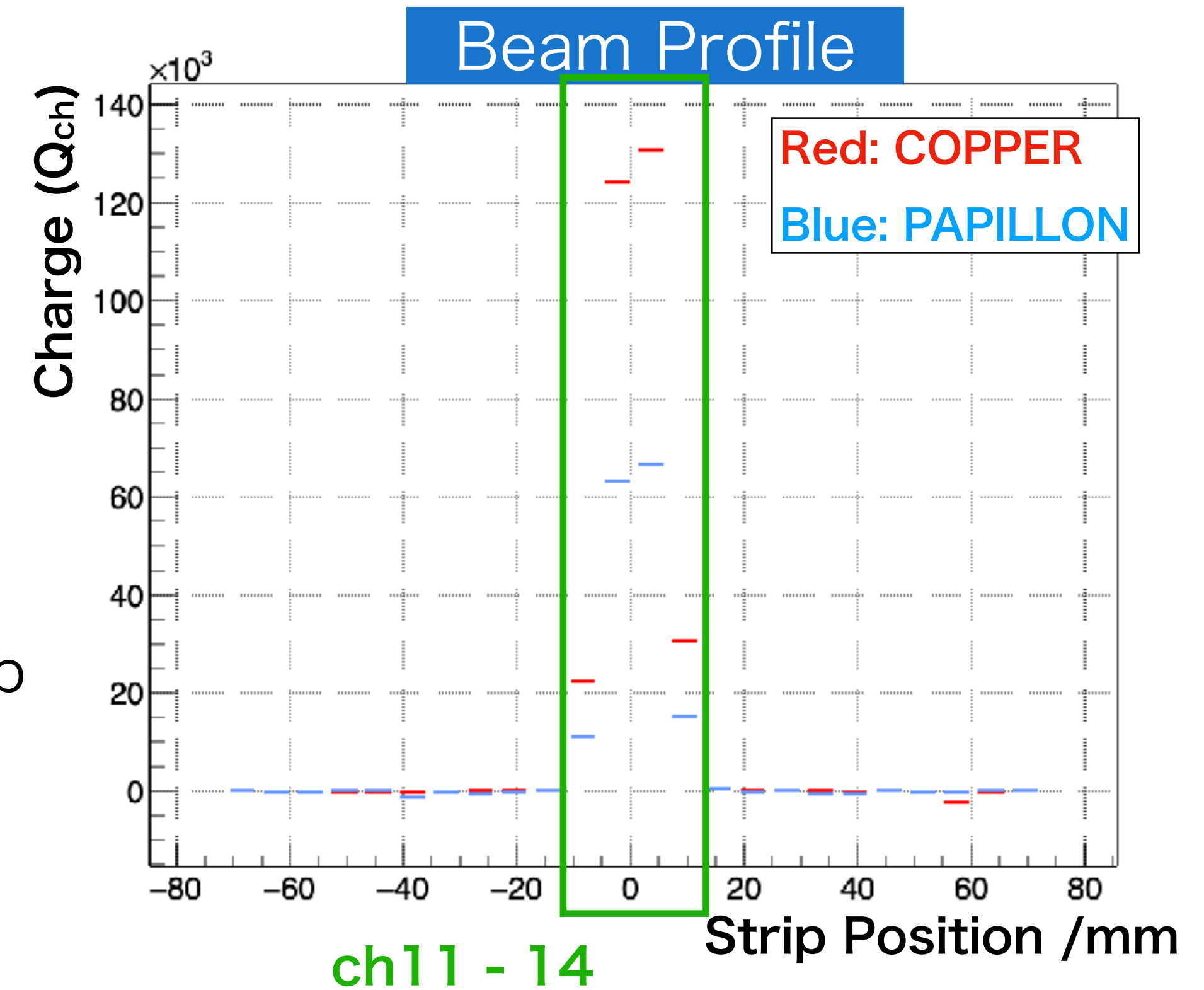

- In waveforms, differences in frequency response are visible
- The PAPILLON FPGA calculation uses strips with  $Q_{ch} > 1200$  (\*)  
-> Only four central strips are used

position:

$$X = \frac{(*) \sum_{ch=0}^{23} Q_{ch} \times x_{ch}}{\sum_{ch=0}^{23} Q_{ch}},$$

width:

$$\sigma_x = \sqrt{\frac{\sum_{ch=0}^{23} Q_{ch} (x_{ch} - X)^2}{\sum_{ch=0}^{23} Q_{ch}}}$$

# Validation of PAPILLON FPGA Calculation 8

- The PAPILLON calculation was **reproduced offline** using the same waveform data
- FPGA output was compared with the offline calculation result

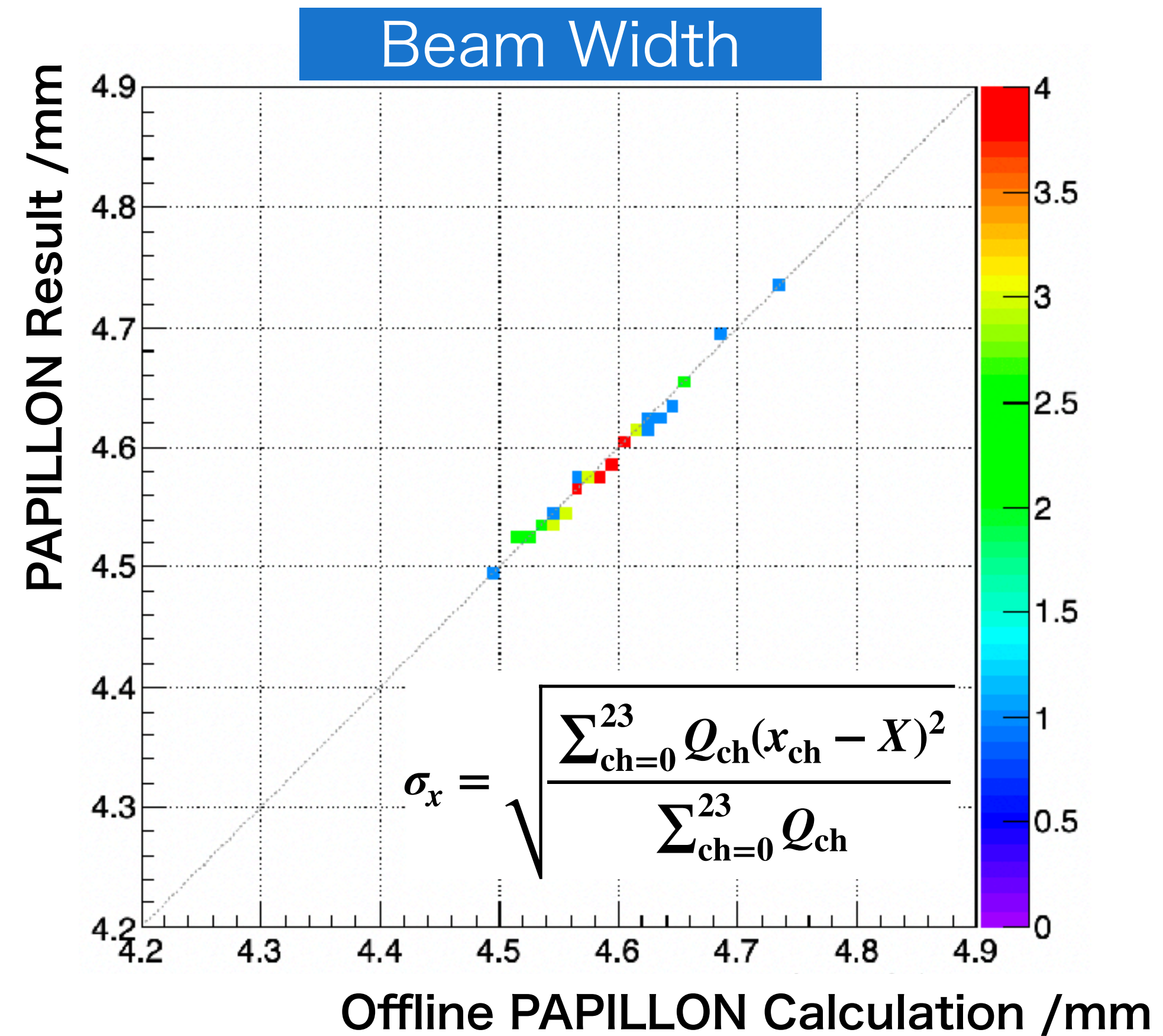
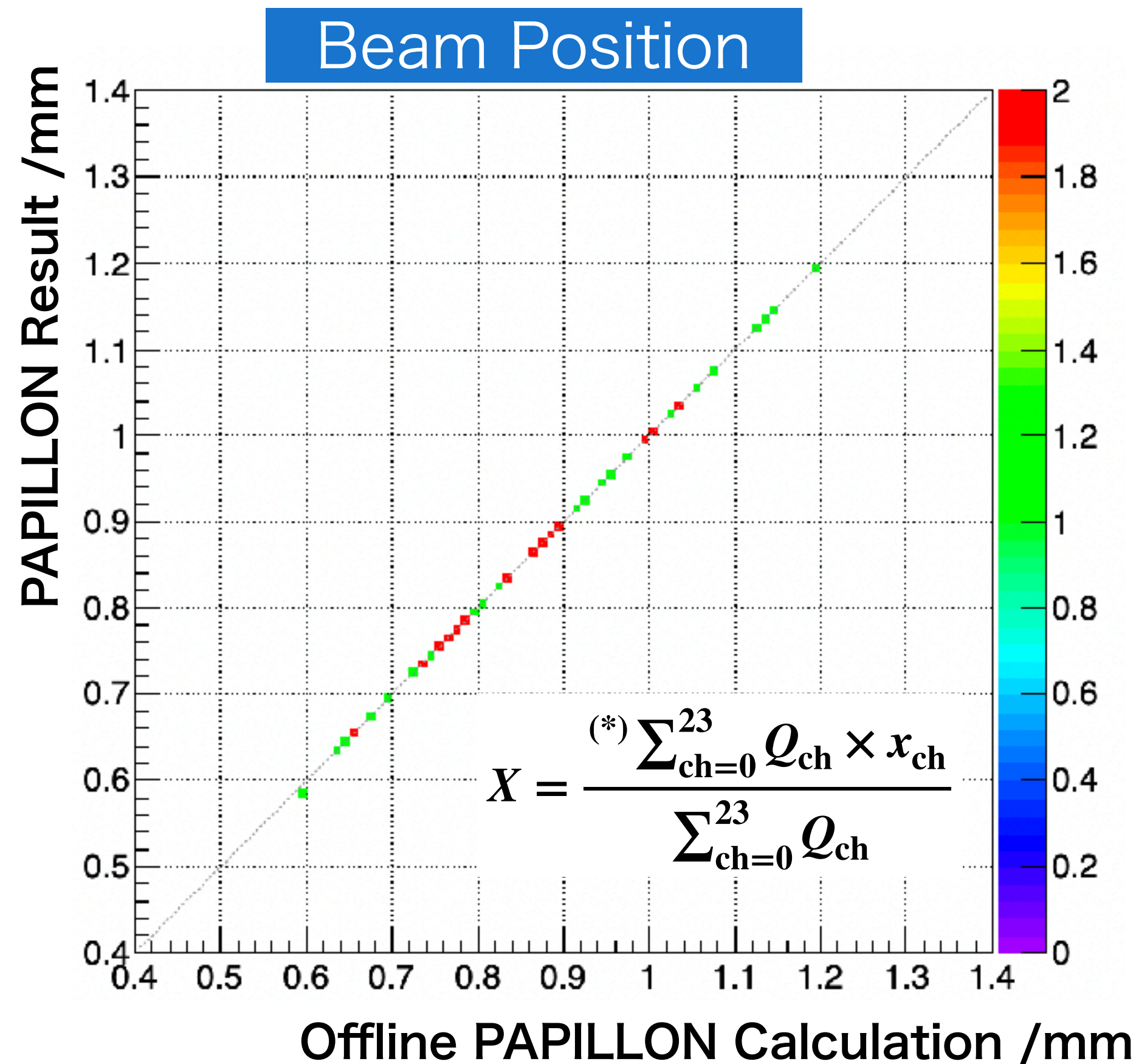

(\*)  $Q_{thr} = 1,200$

-> The FPGA implementation of the PAPILLON calculation **works as expected**

# BeamTest Result

- BeamTest (PAPILLON FPGA results vs T2K offline analysis)
  - **Position:** PAPILLON results show a systematic offset of about -0.1 mm
  - **Width** : PAPILLON results are larger, especially for narrow beams

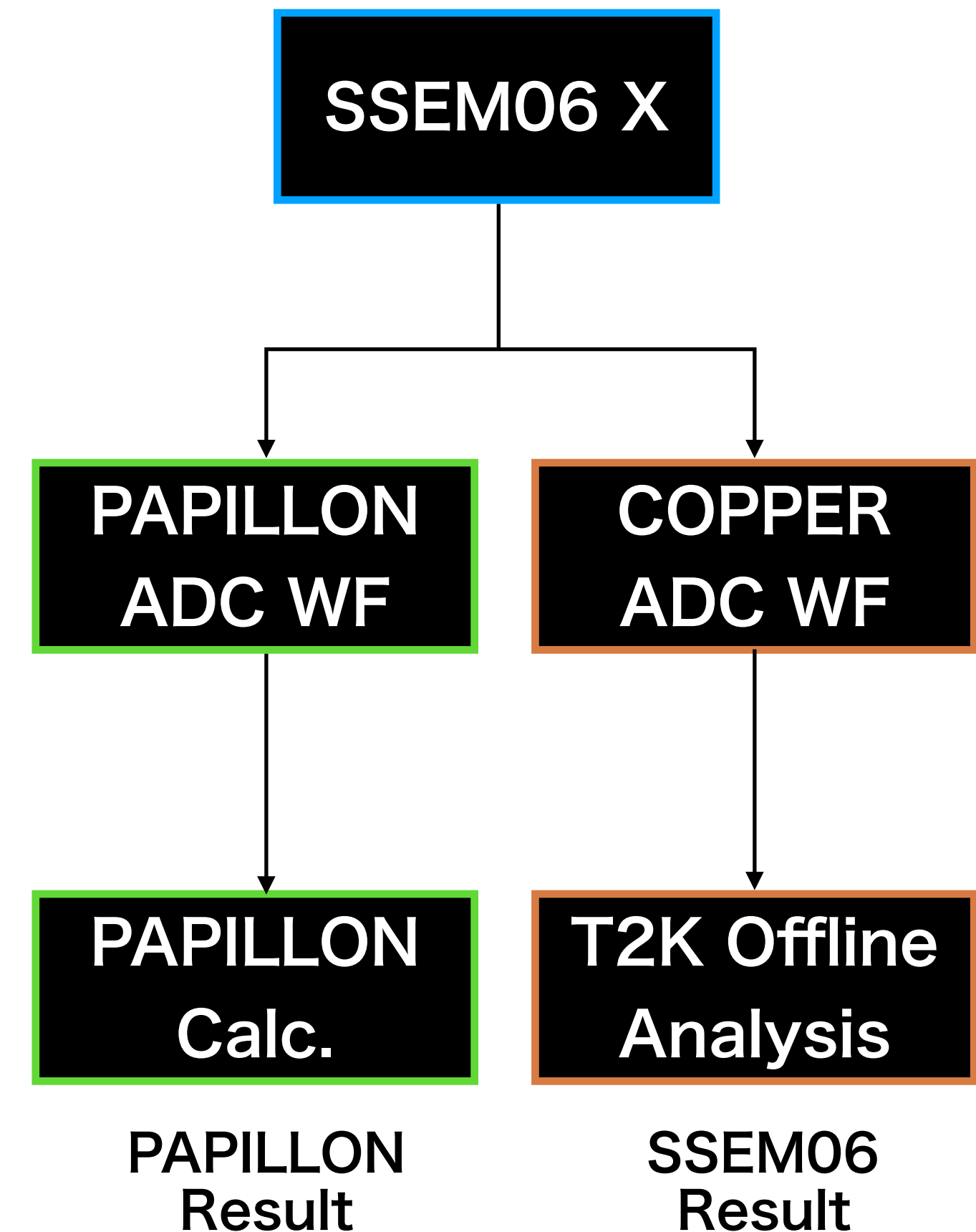
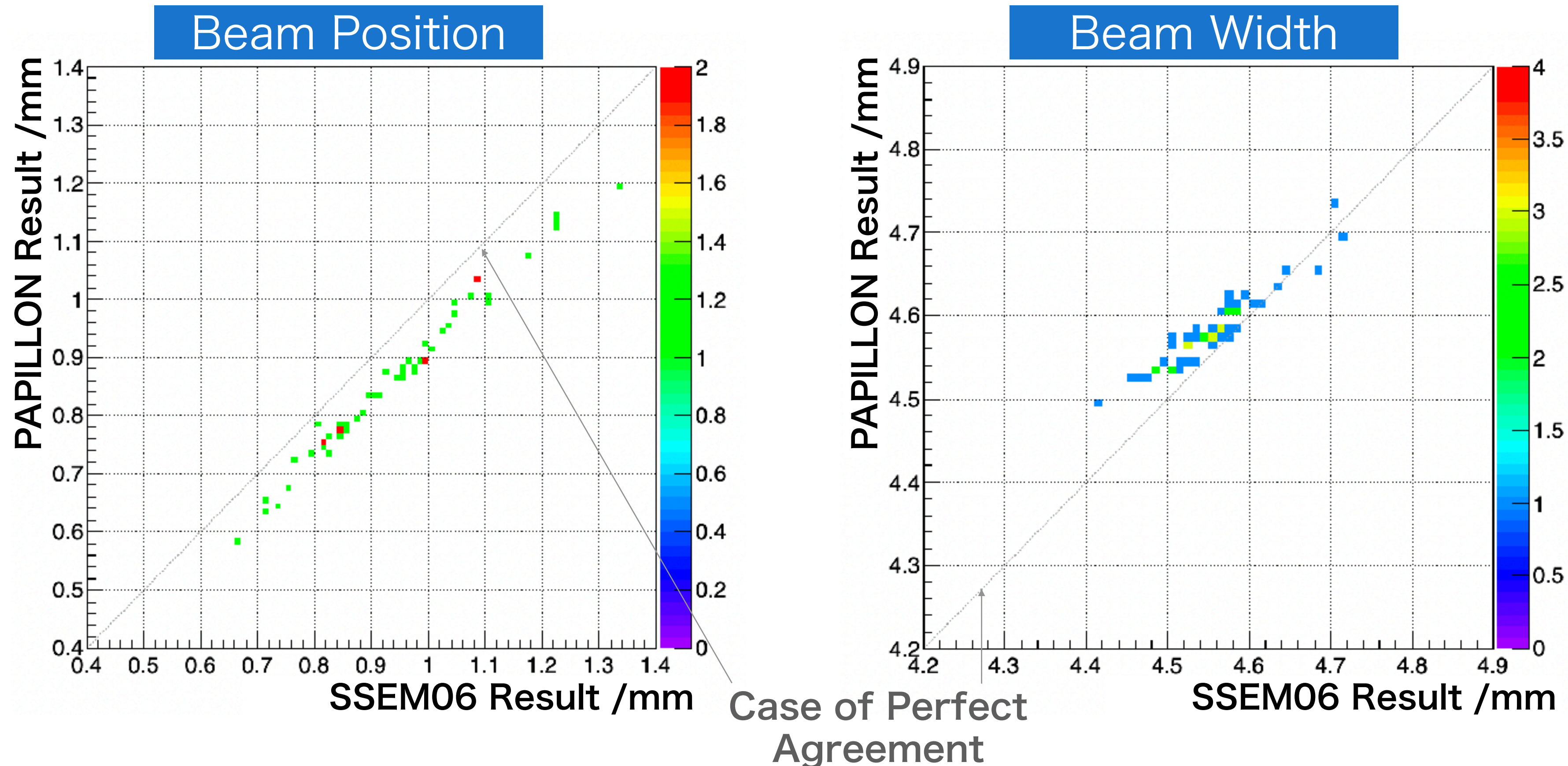

# Comparison of Waveform and Calc.

- The observed difference between PAPILLON and T2K offline analysis can come from two sources:

## 1. Waveform difference

- Differences in frequency response are visible in the waveform shapes

## 2. Calculation difference

- PAPILLON: Charge-weighted average
- T2K offline: Gaussian fit (bunch by bunch)

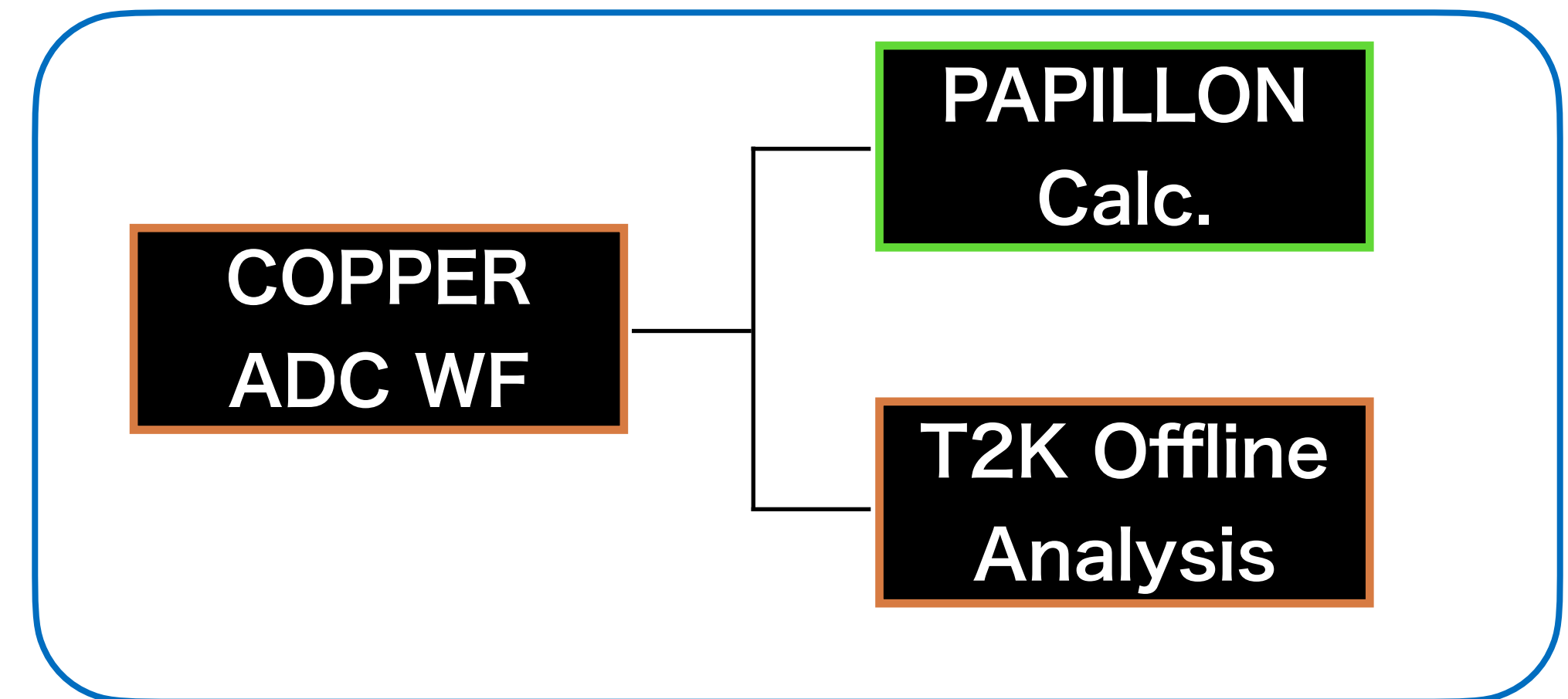
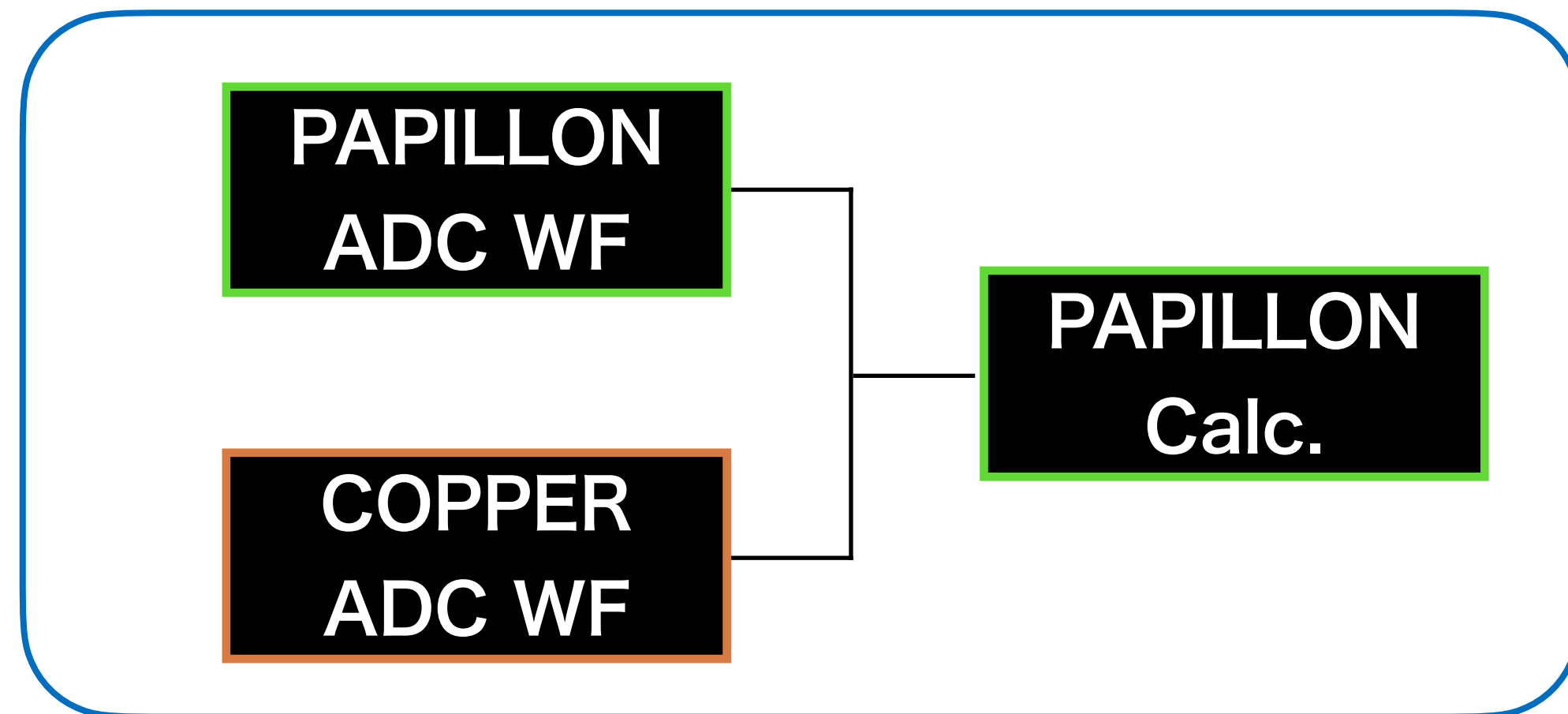

-> Evaluate these two effects separately

# 1. Impact of Waveform Differences

- The PAPILLON method was applied offline to both PAPILLON and COPPER waveforms
  - > Evaluate the impact of waveform differences on the calculated results
- The two results are in relatively good agreement
  - > Waveform differences are **not the dominant source** of result differences

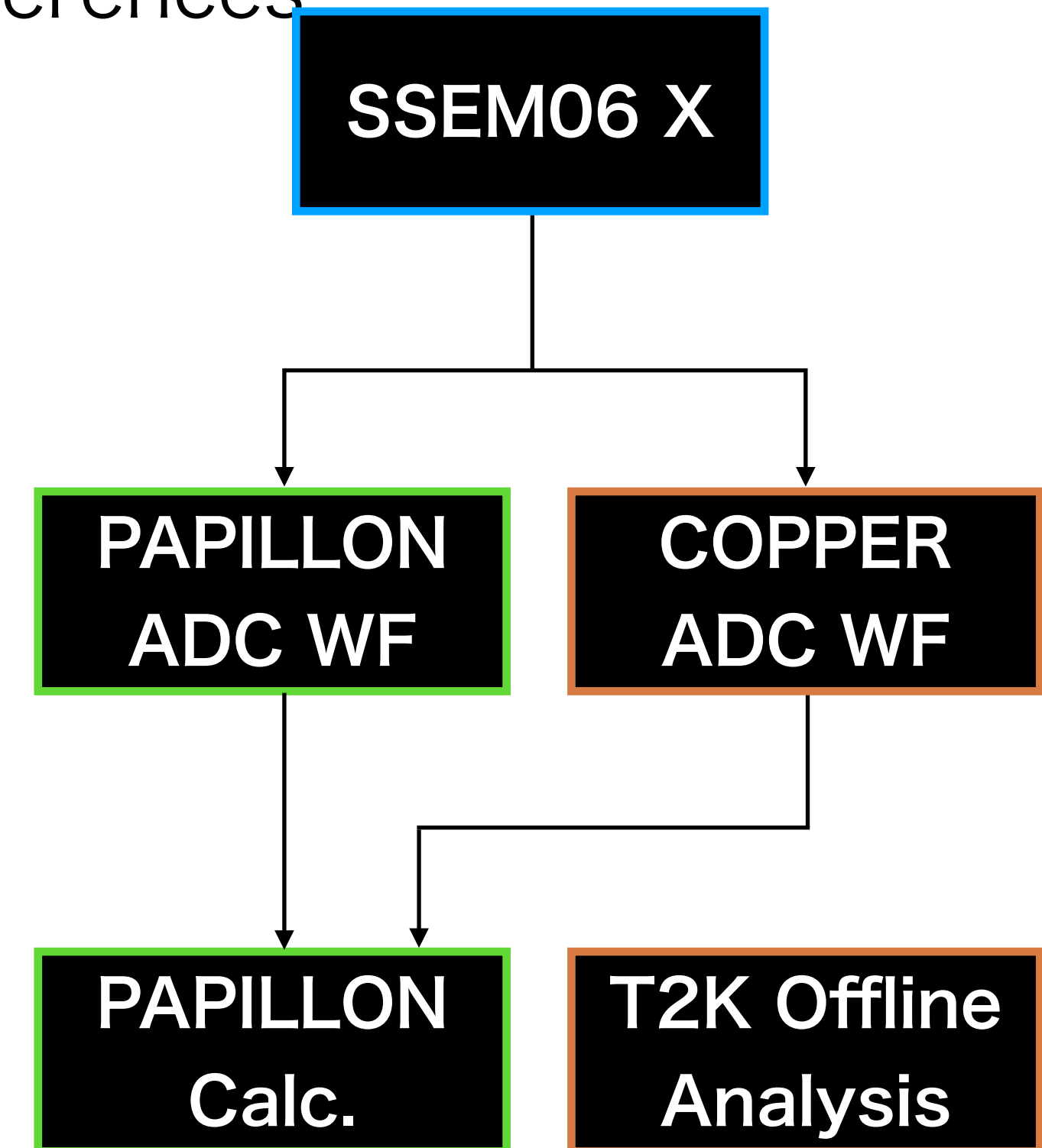
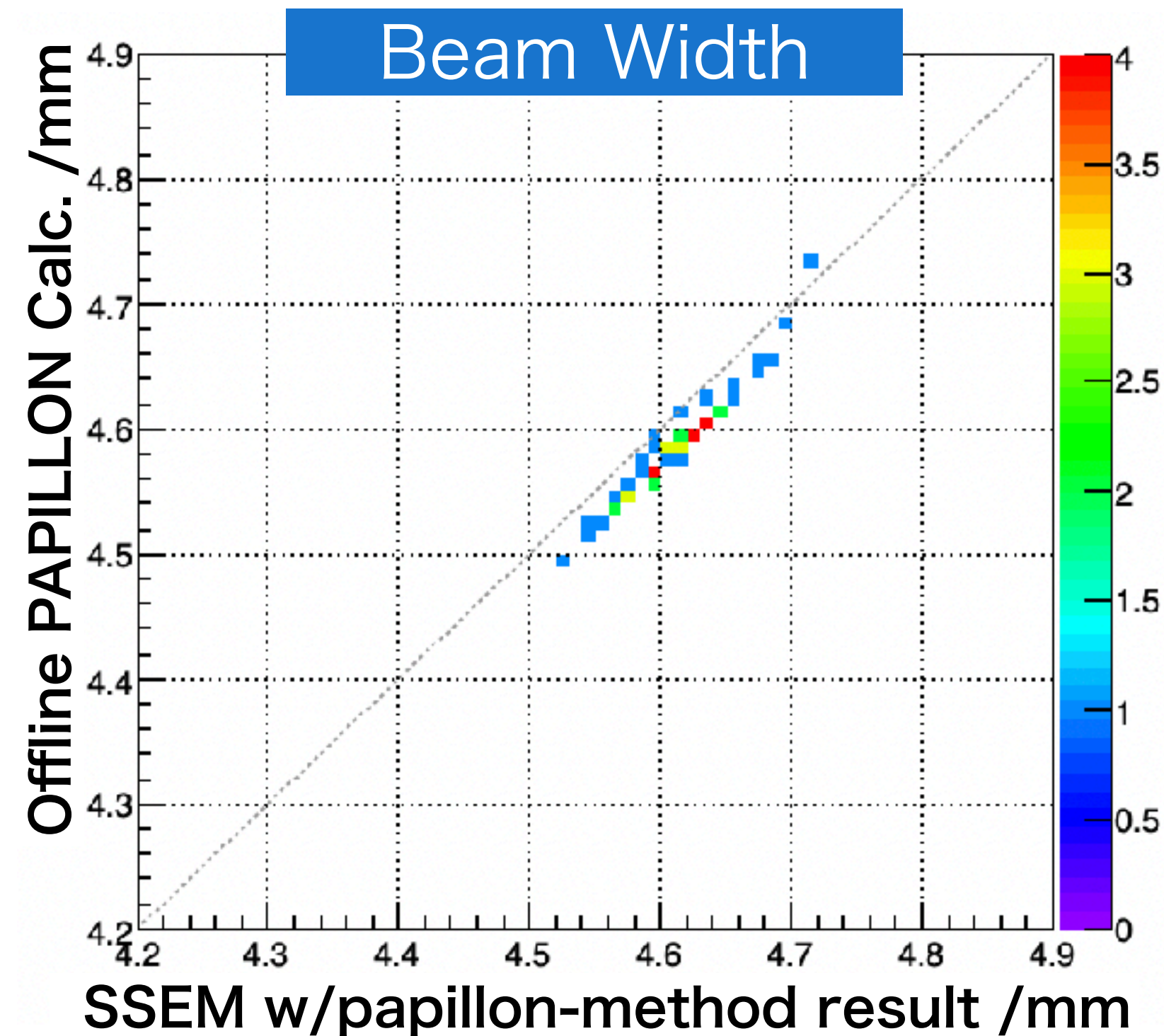
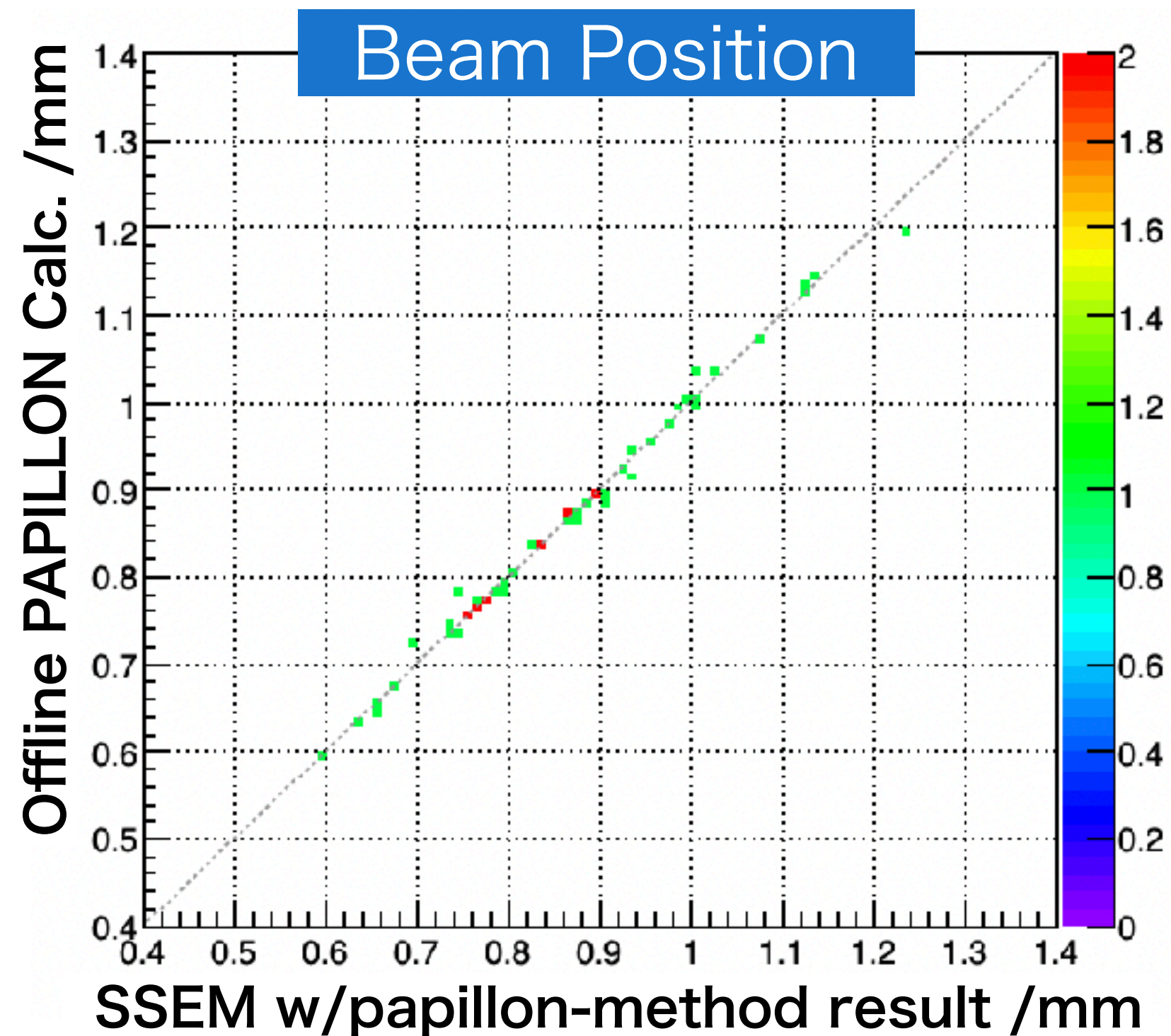

# 2. Impact of Calculation-Method Differences 12

- The PAPILLON-method calc. was compared with T2K offline analysis (w/ COPPER waveform)
- Similar trends to the original beamtest comparison are observed:
  - Position: a systematic offset / Width: the PAPILLON-method results are larger
- The linearity looks good

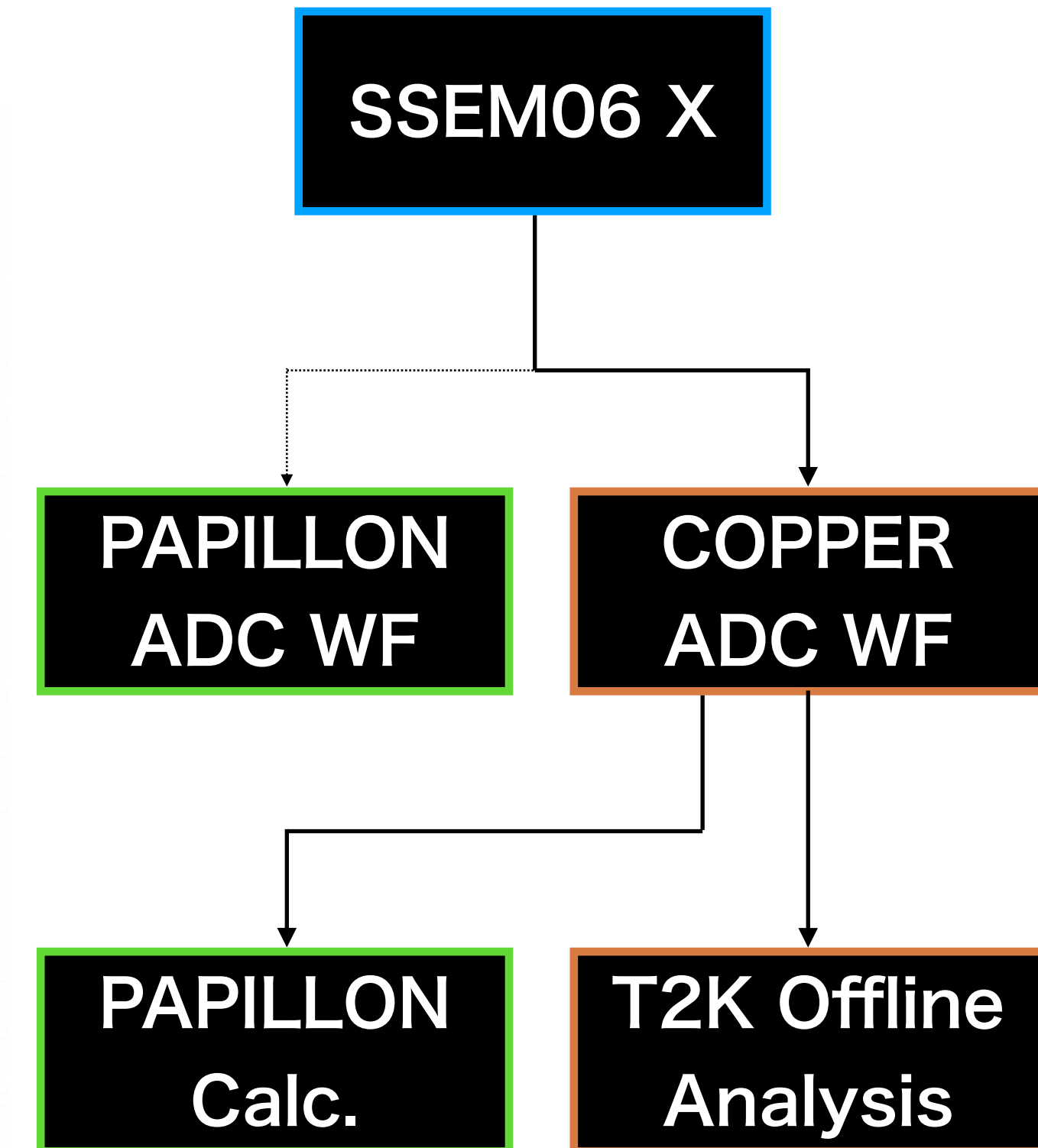
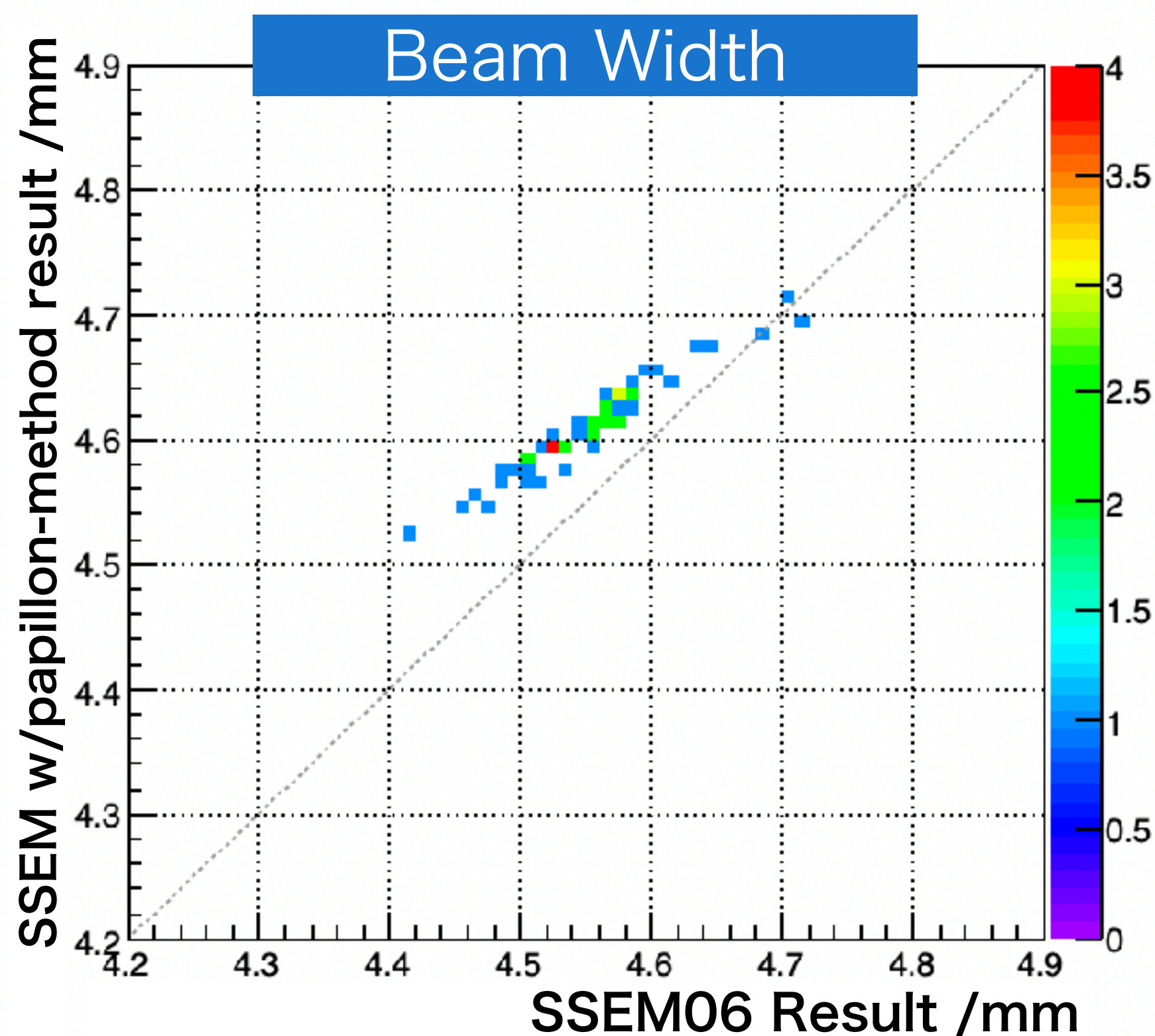
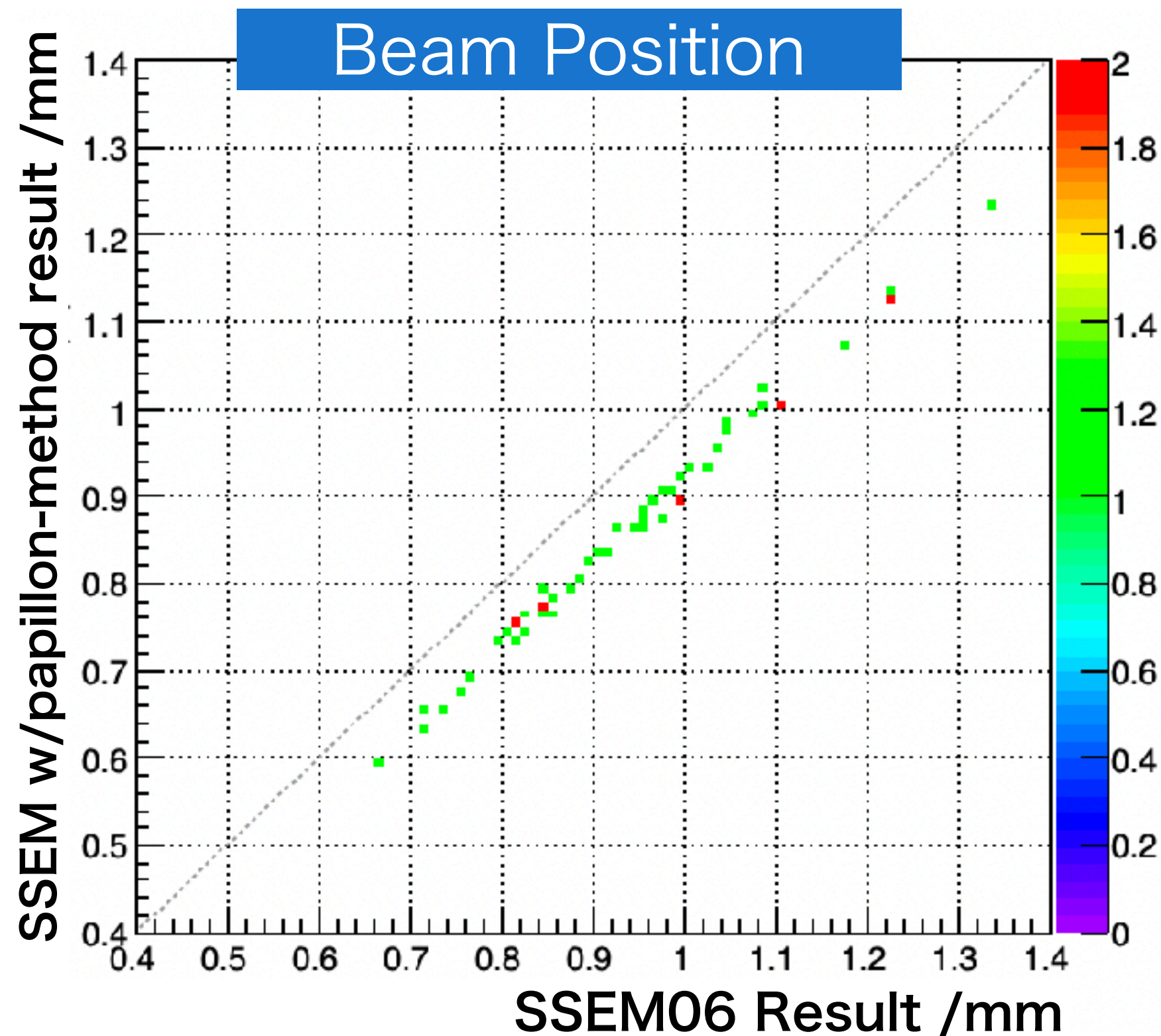

## Summary

- The **target protection system** needs to be upgraded for the 1.3 MW beam operation.
- A new **FPGA-based** module, PAPILLON, has been developed as the interlock system.
- PAPILLON was updated to v3, and a **beamtest** was performed with SSEM06
  - > A difference due to the calculation method was observed, but the linearity with respect to the offline analysis results looks good

## Next steps

- We plan to perform the next **beamtest with SSEM19**
- Take data under several beam configurations to check the linearity over a wider range of position and width
  - > If this linearity is confirmed, the position/width thresholds for PAPILLON interlock can be determined using this relationship.

# Backups

# Previous Study : PAPILLON v2

- PAPILLON v1 and v2 have been developed (v3 is currently under development)
- The calculation method of PAPILLON is validated by comparing it with offline analysis
- The offline system (COPPER) receives SSEM output from the PAPILLON board and processes it.

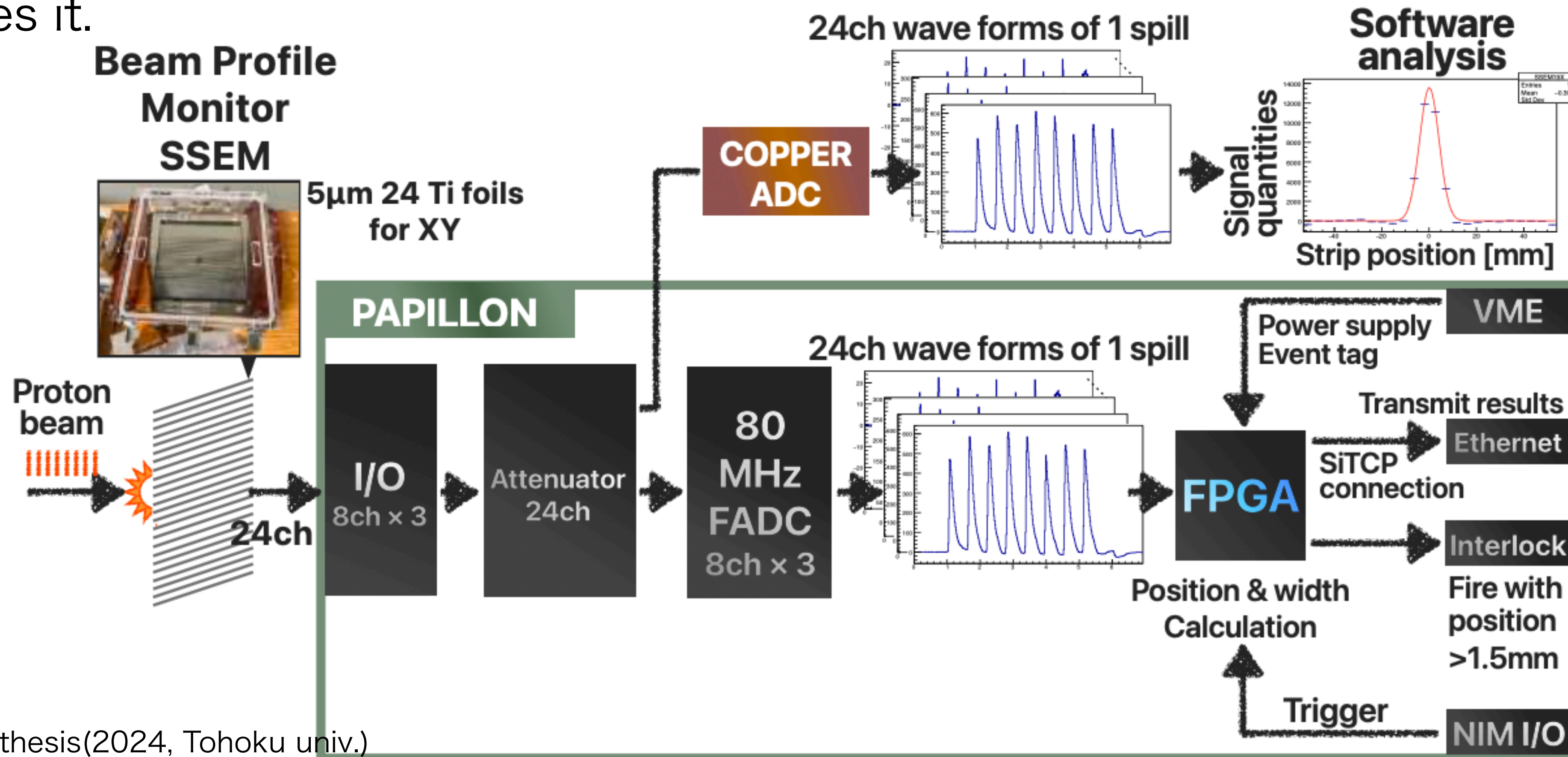

# Previous BeamTest in 2023

- PAPILLON v2 beamtest with SSEM19
  - **Position:** beam was injected off-center on the target; 10 spills taken at each point
  - **Width:** beam width varied; 10 spills taken for each
- PAPILLON FPGA results vs T2K offline analysis results (SSEM19 Result)

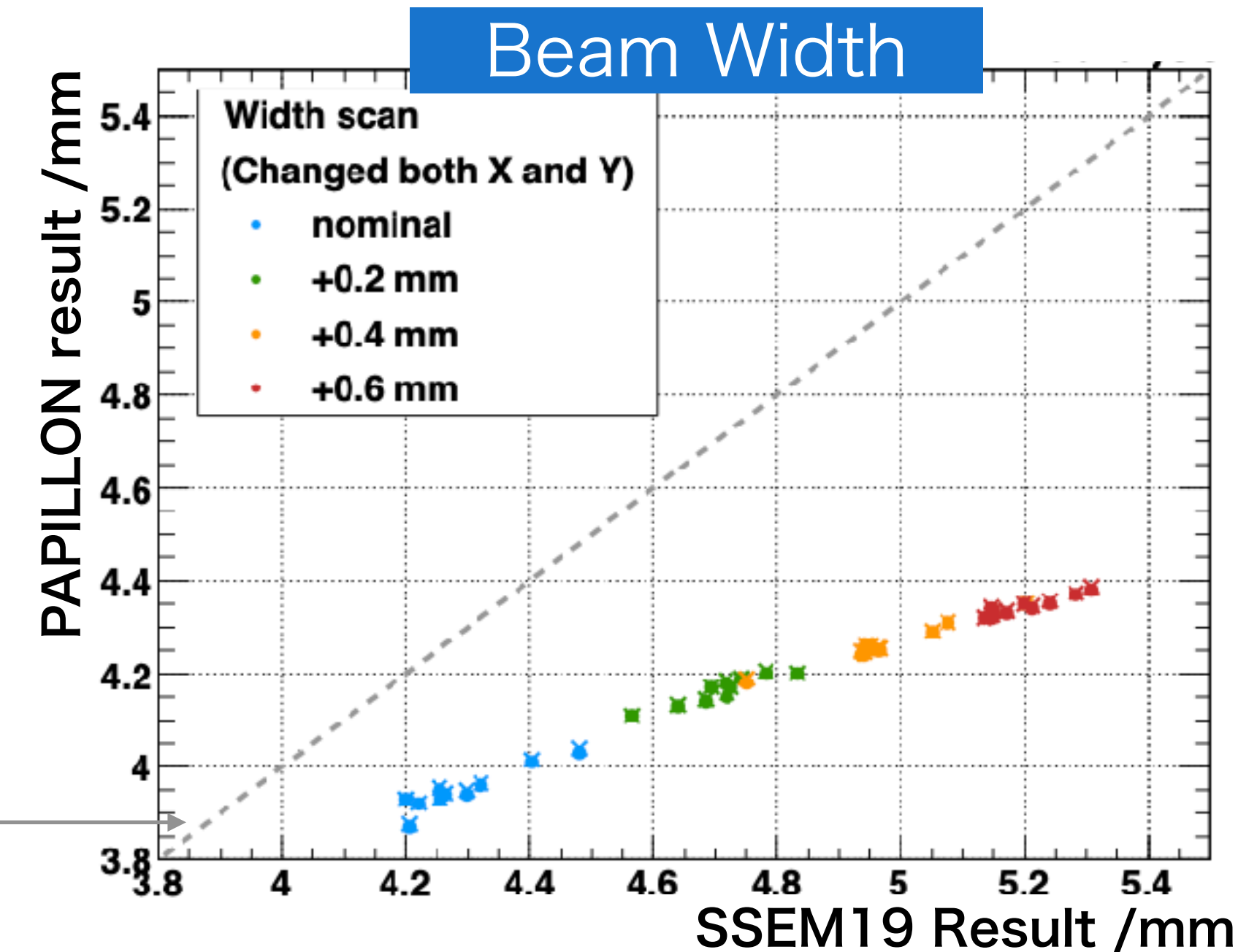
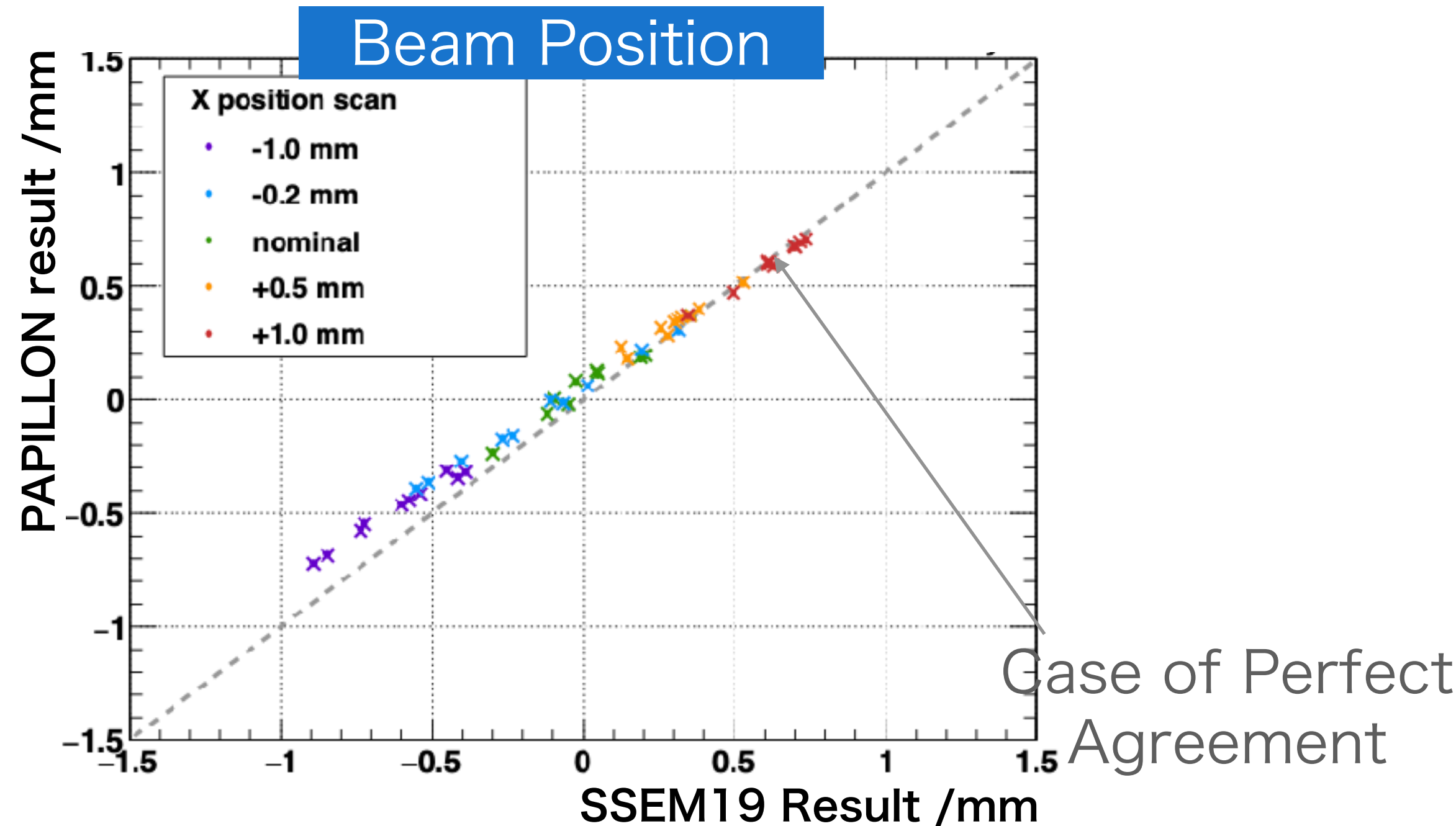

→ **Good linearity was obtained, but the beam width from PAPILLON was smaller than that from the offline analysis.**

# Change the Threshold of PAPILLON Calc. (Offline) 17

- **BeamTest:** Integrated ADC counts ( $Q_{ch}$ ) **thr = 1,200**
  - > PAPILLON calculation uses only the **four central strips**
- Change the **thr -> 500** (ch15 is included in calc.)
  - > Compare with SSEM06 results (= T2K offline analysis)

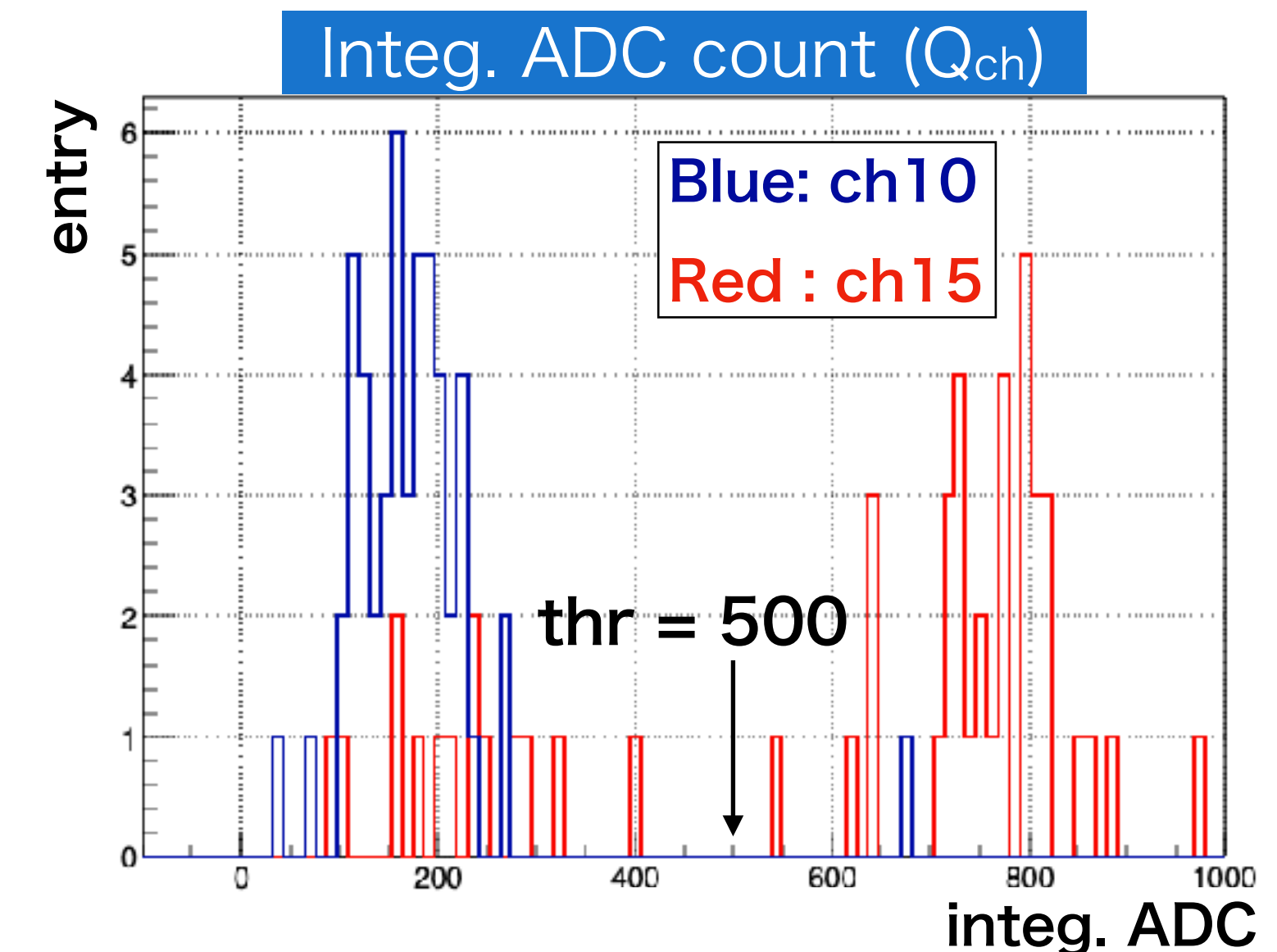
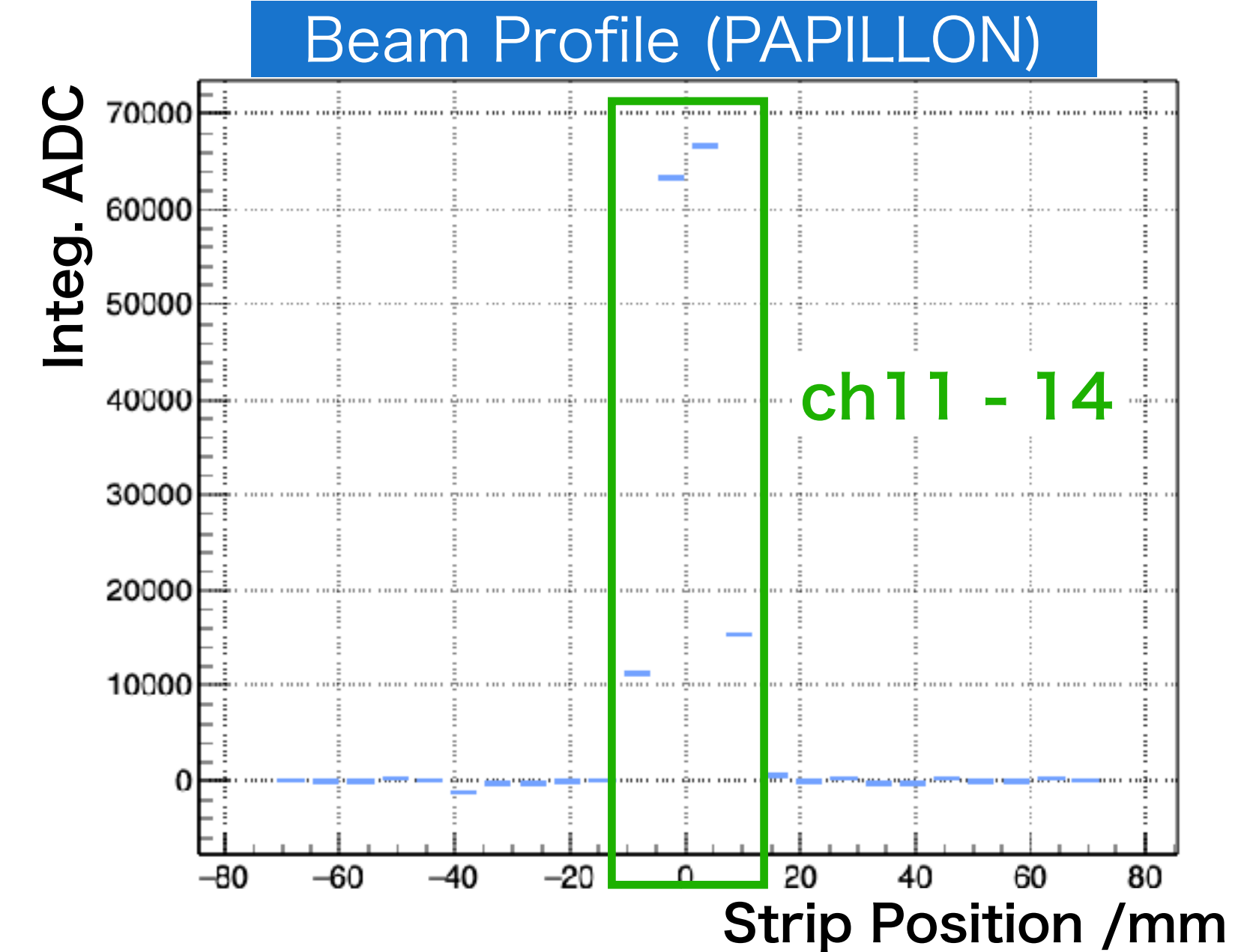
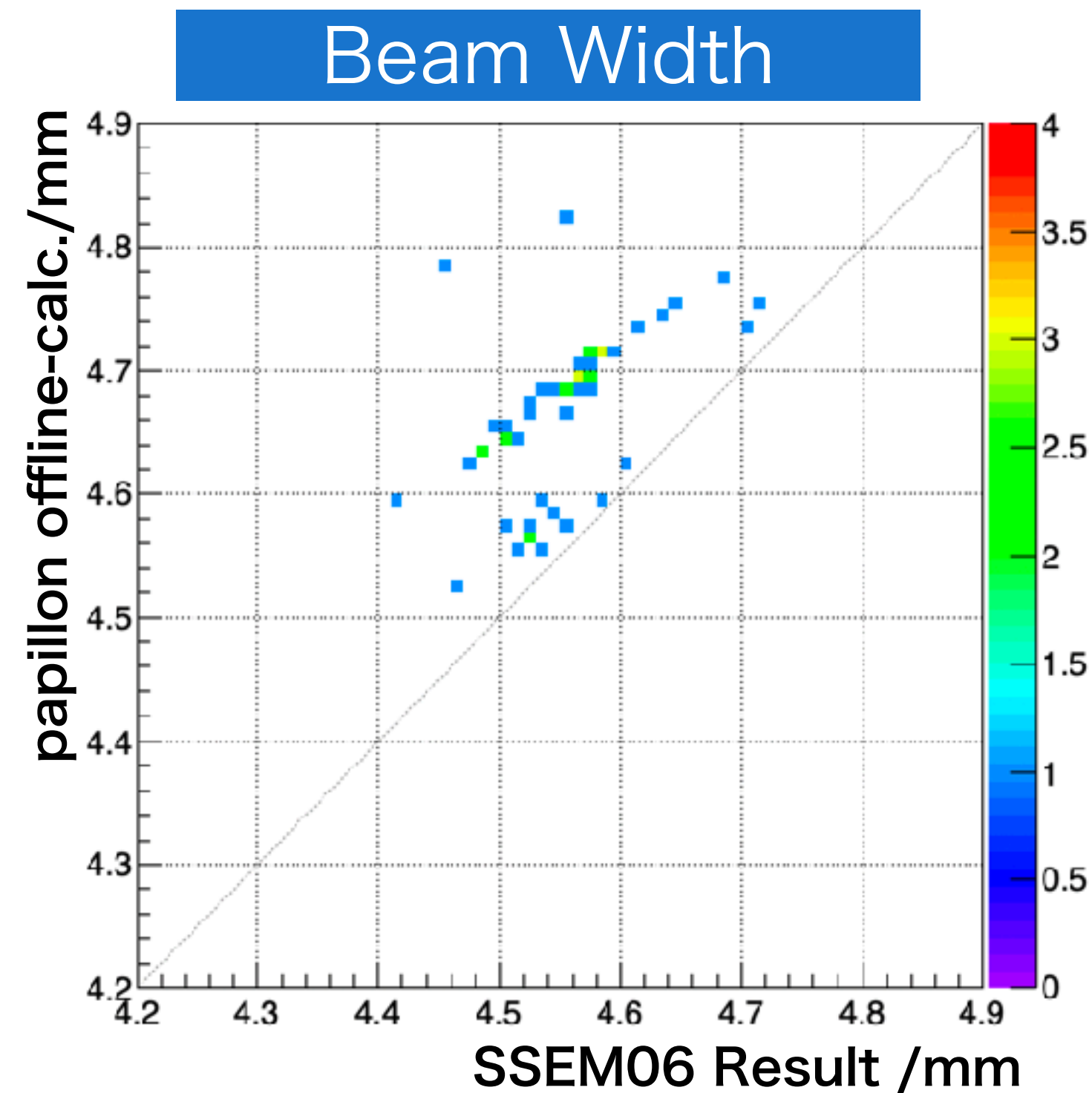
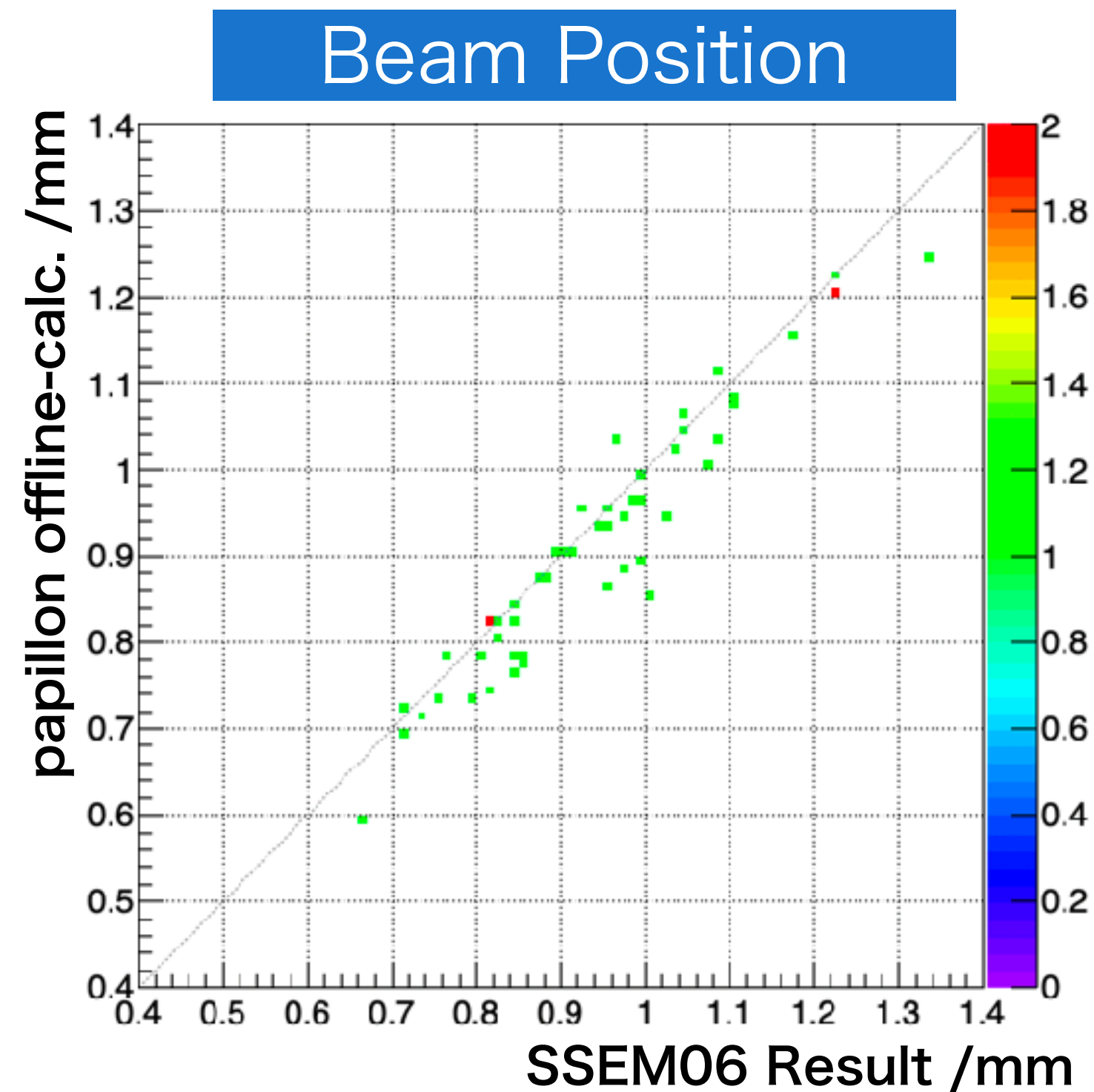

# Integ. ADC count (PAPILLON)

ch 1 ~ 10

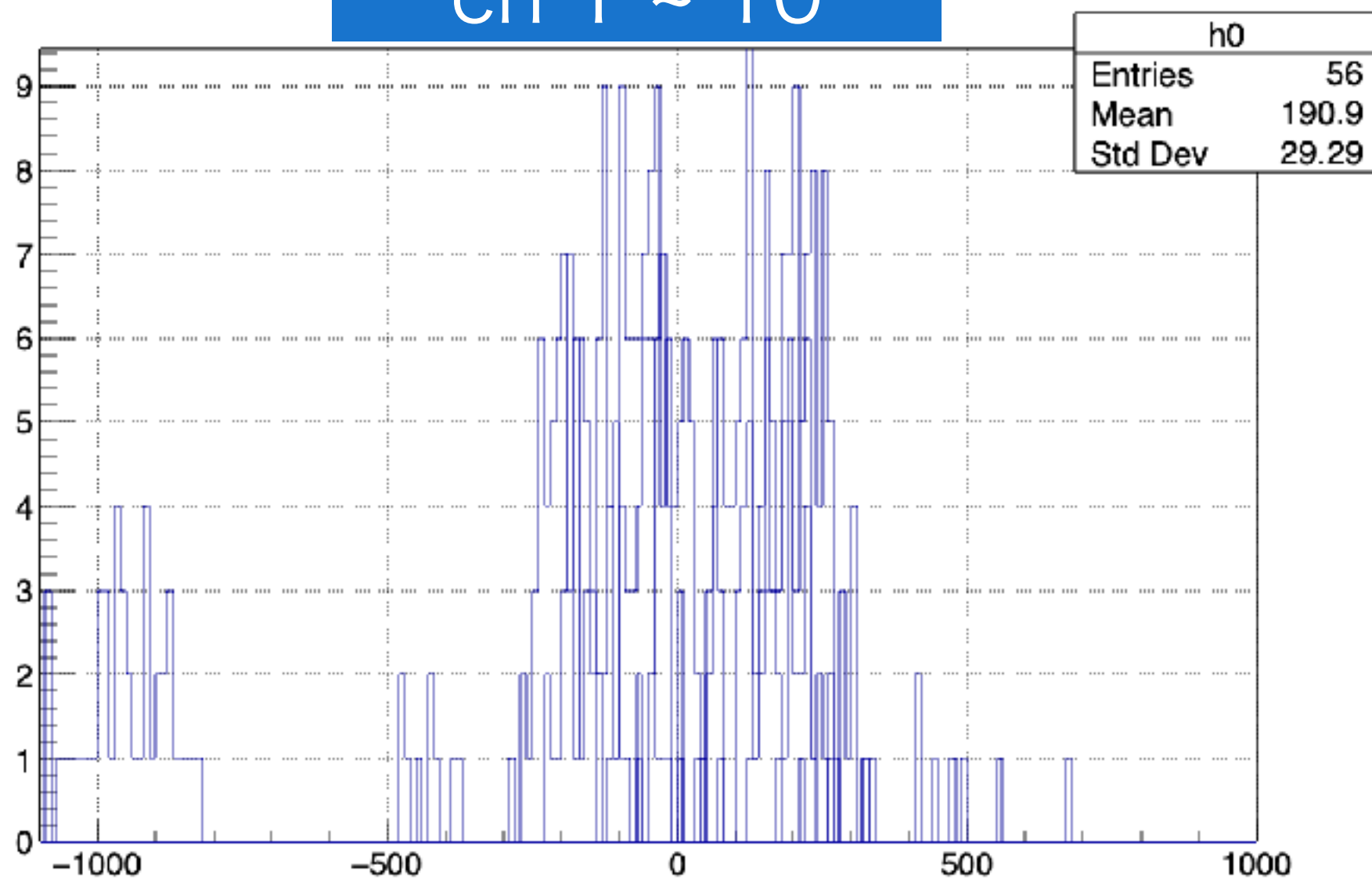

ch 16 ~ 24

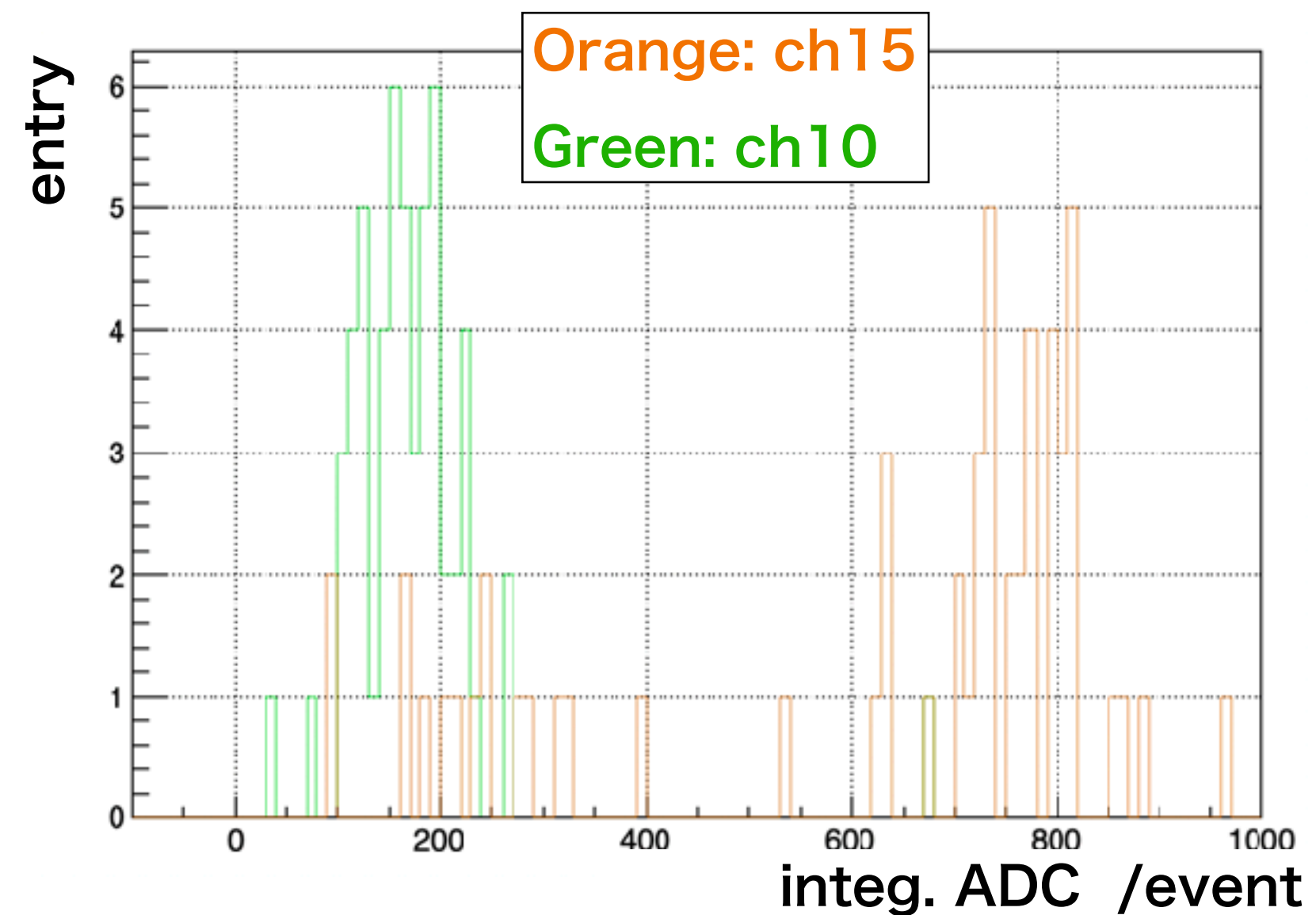
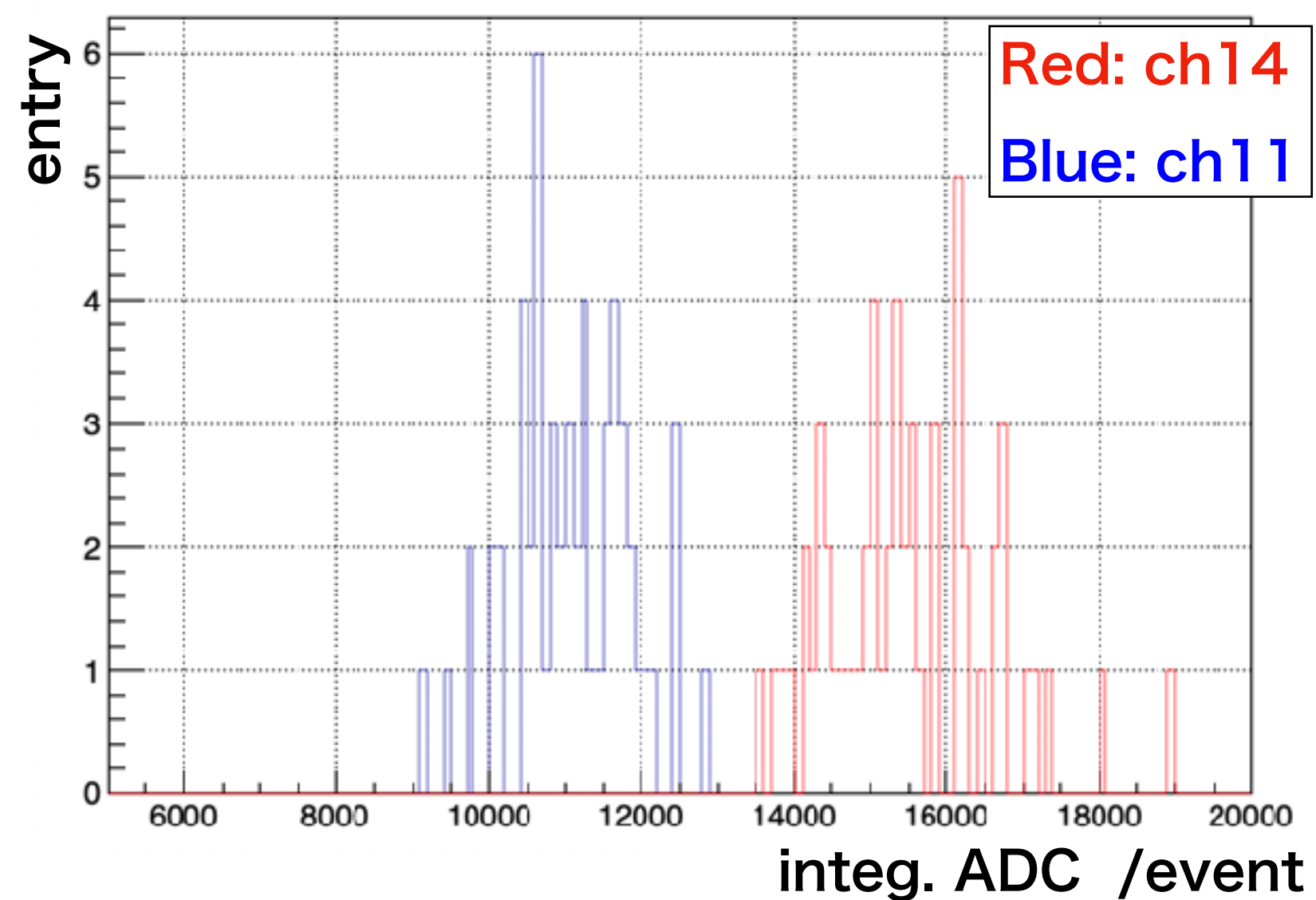
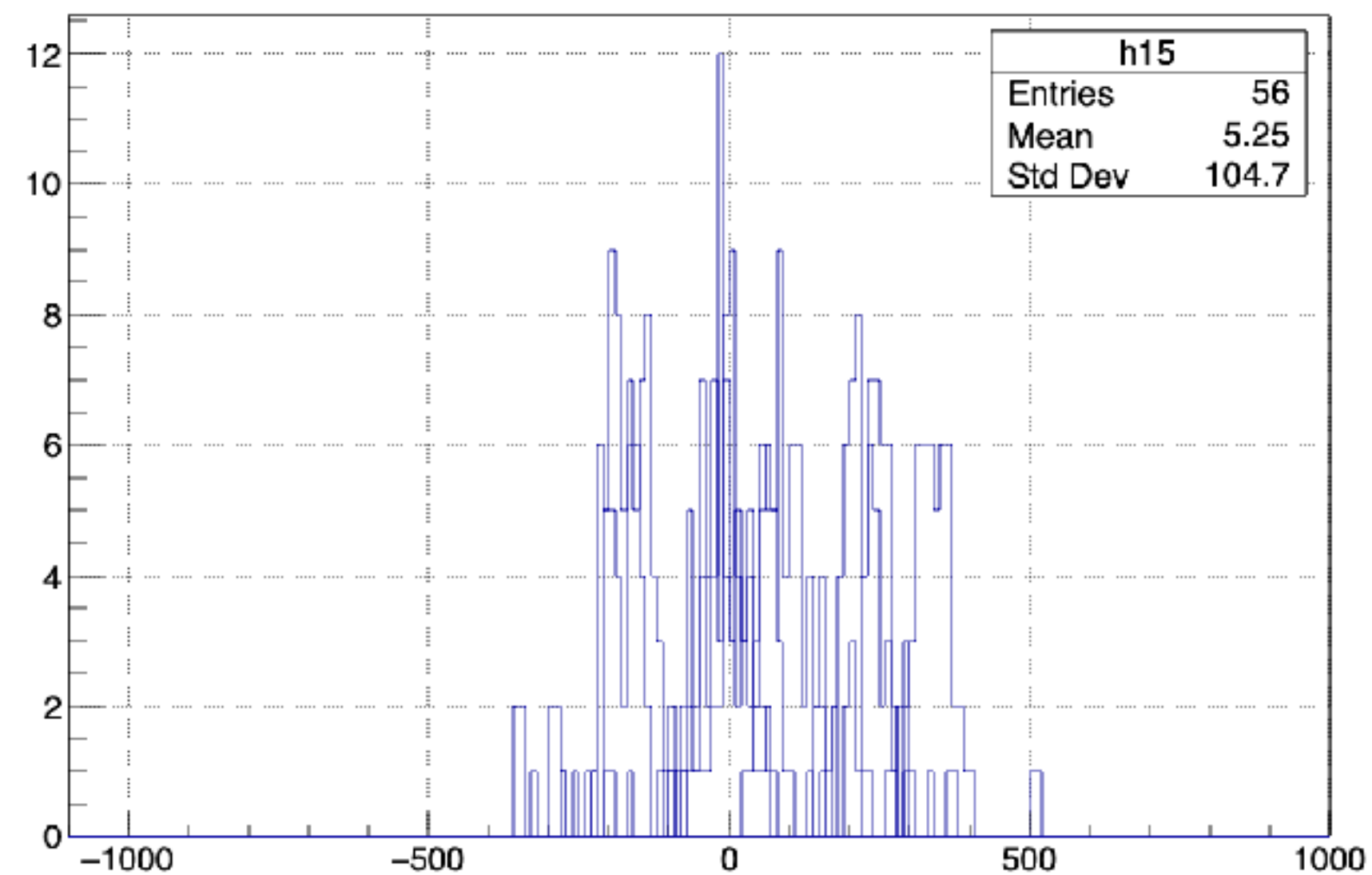

# PAPILLON Processing Time

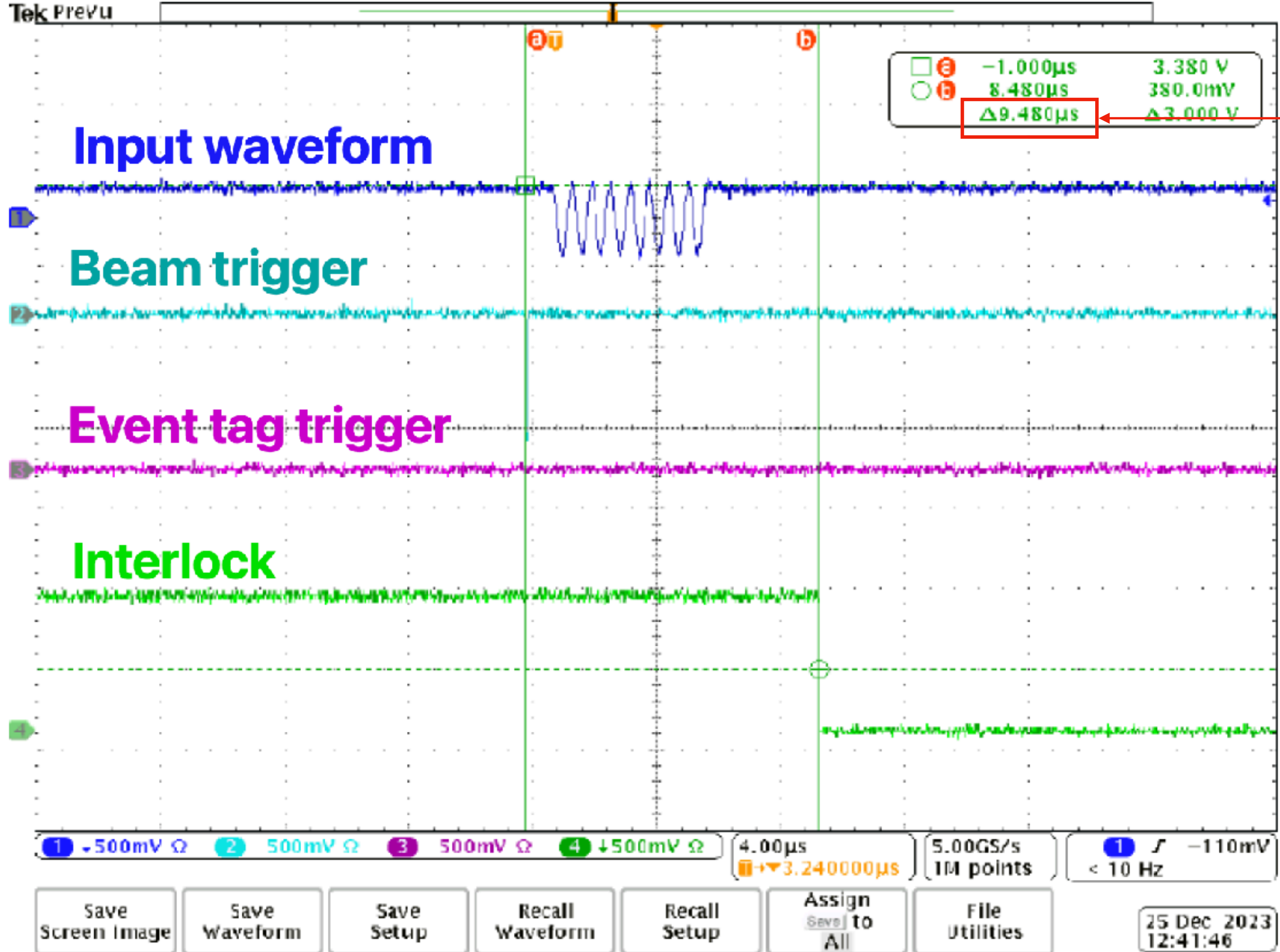

$\Delta ab = 9.48 \mu s$

# Frequency Response

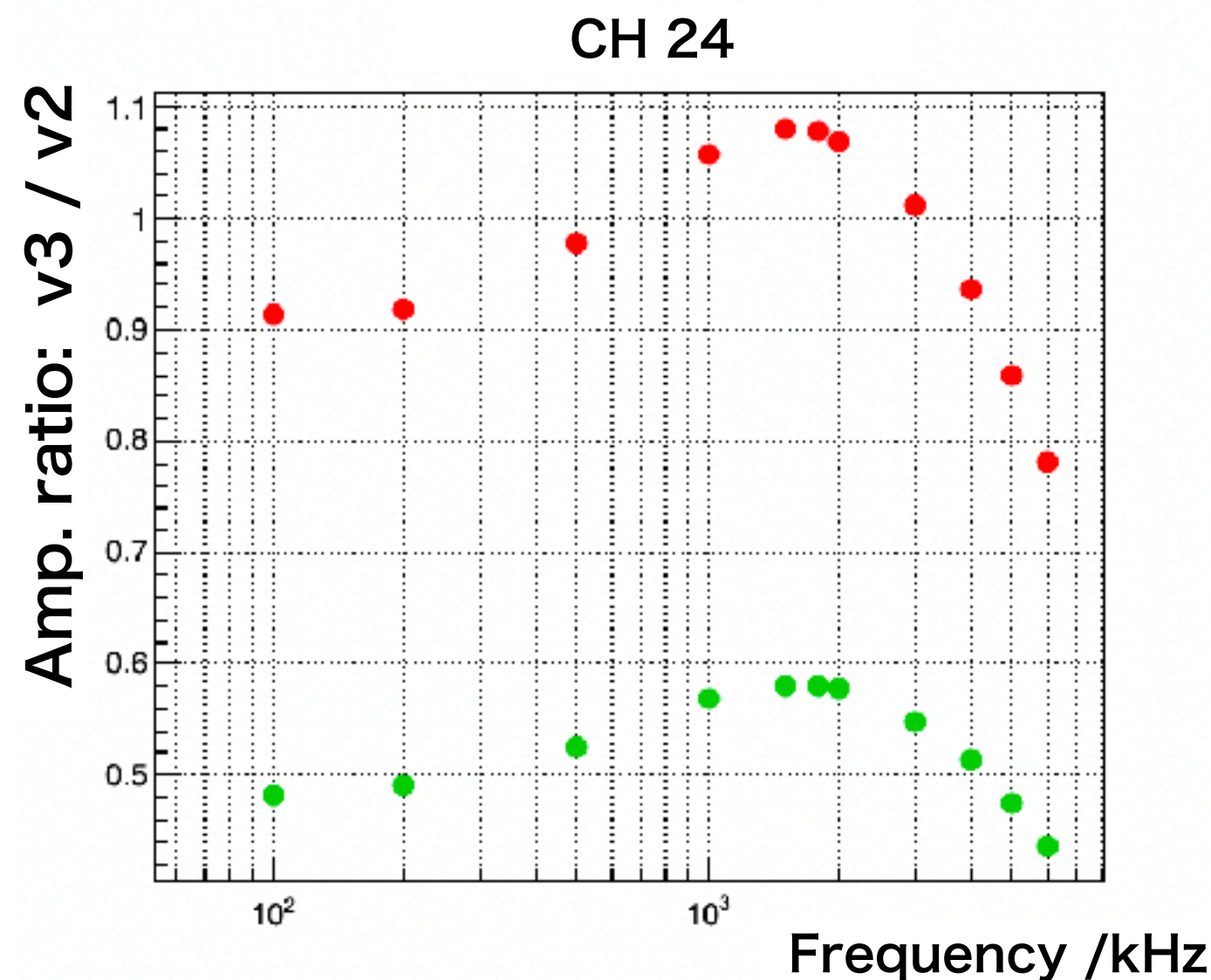
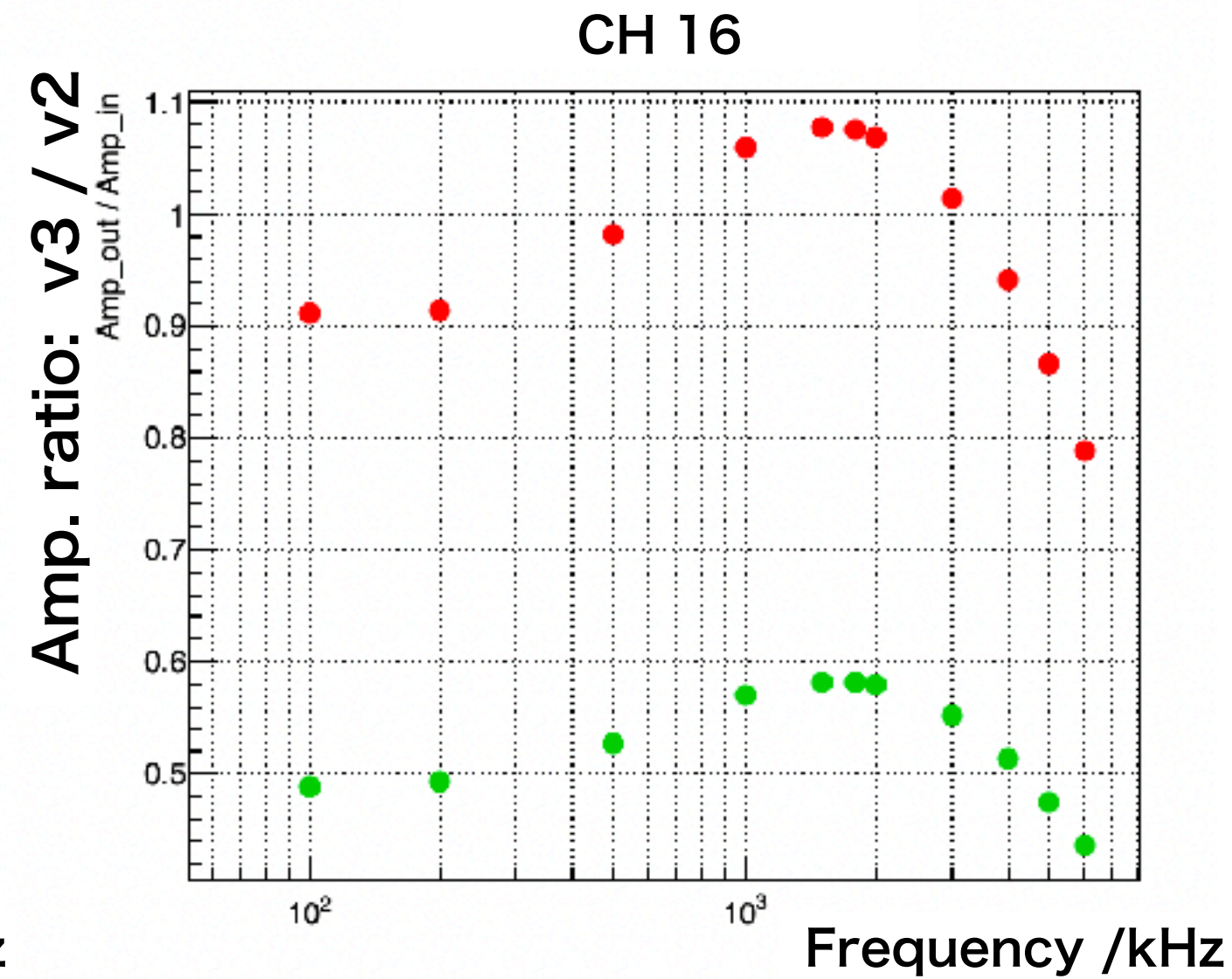
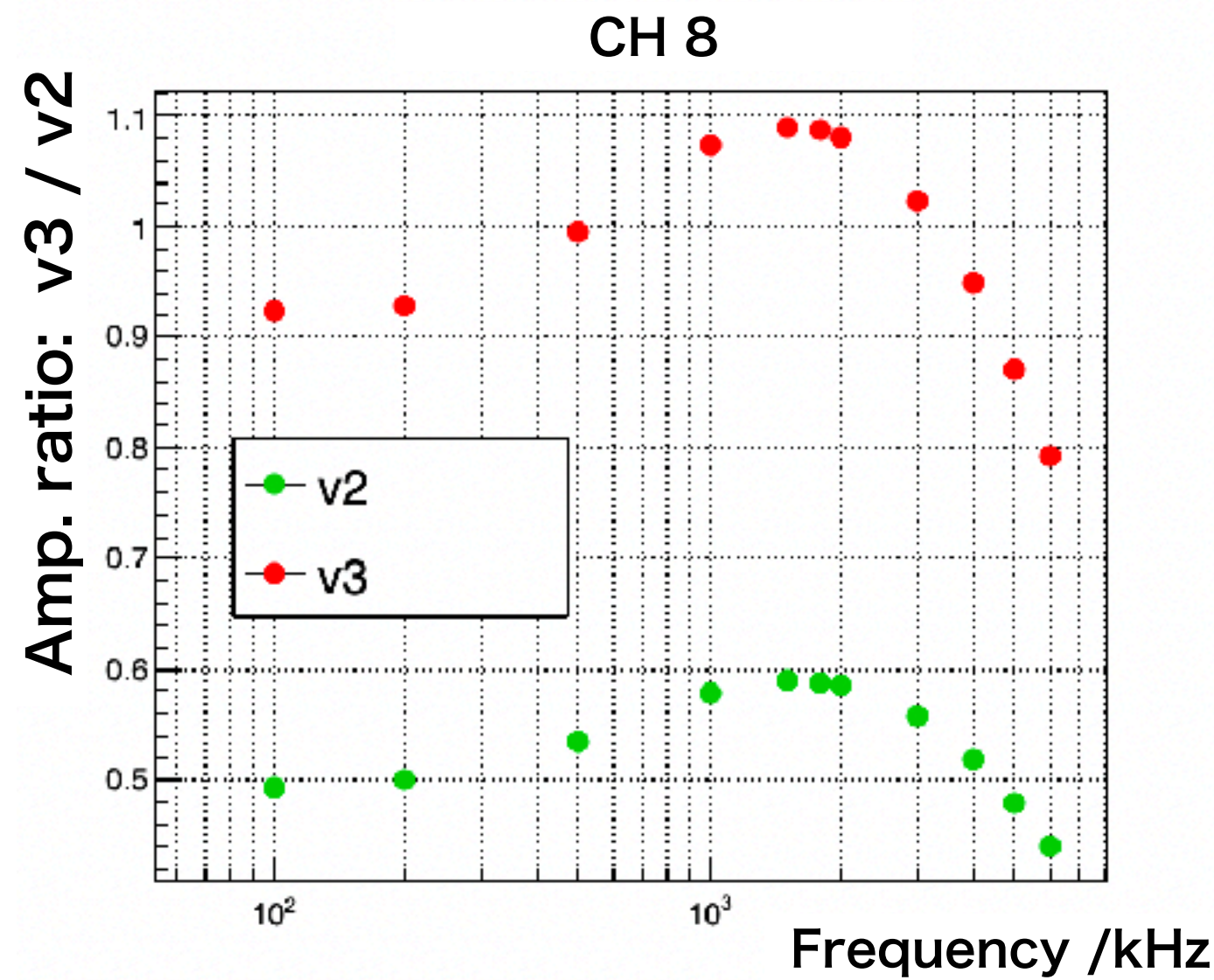

- Measured the frequency response on multiple channels.
- The maximum gain was obtained at 1.5 MHz input.  
(cutoff frequency  $f = 5.13$  MHz)

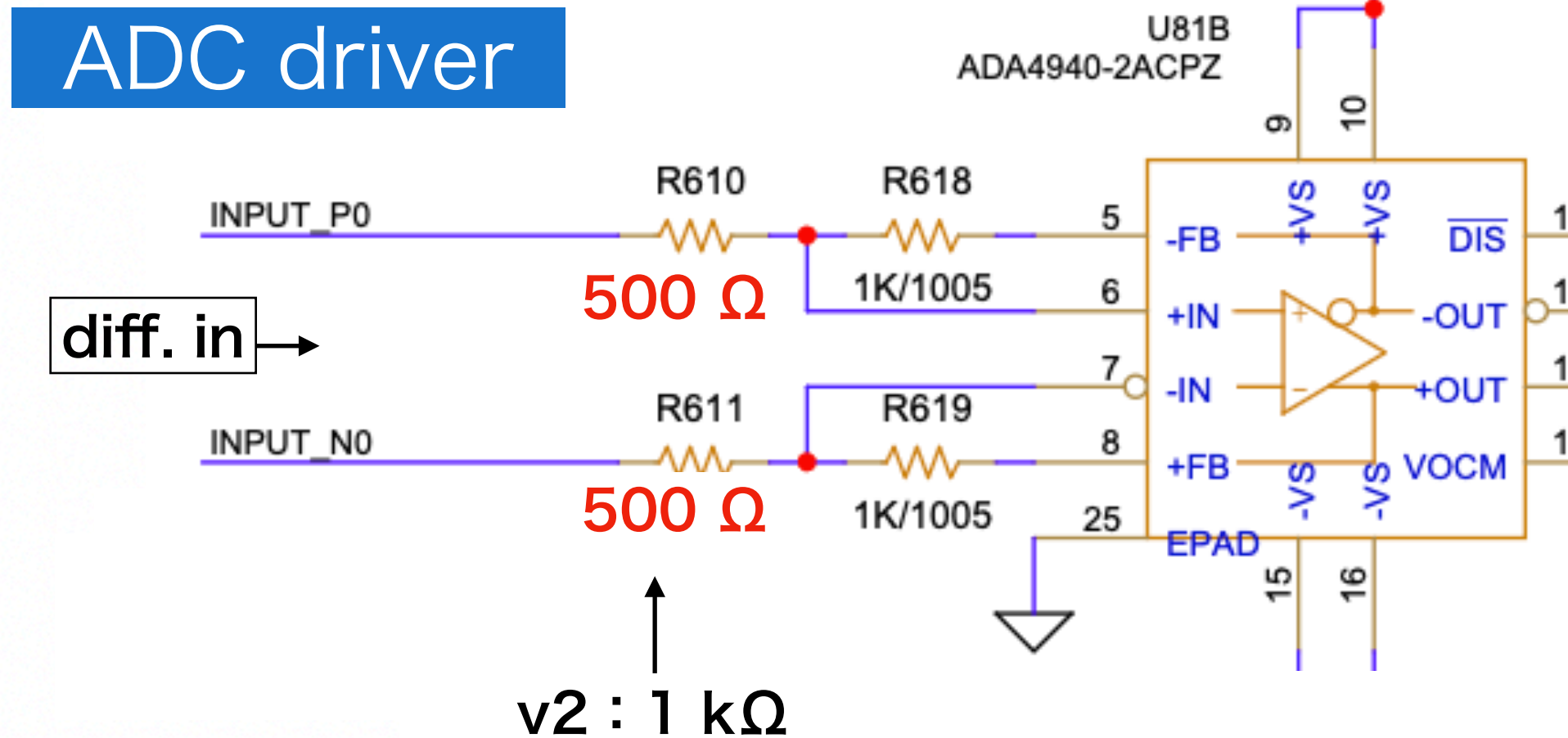

# Gain Verification

- Measure a sine wave with PAPILLON v2 and v3
  - Calc. the average amplitude of the waveform
  - Obtain the gain ratio from the amplitude ratio
- The gain has a frequency dependence
  - > the same-frequency signal is fed into both

Setup

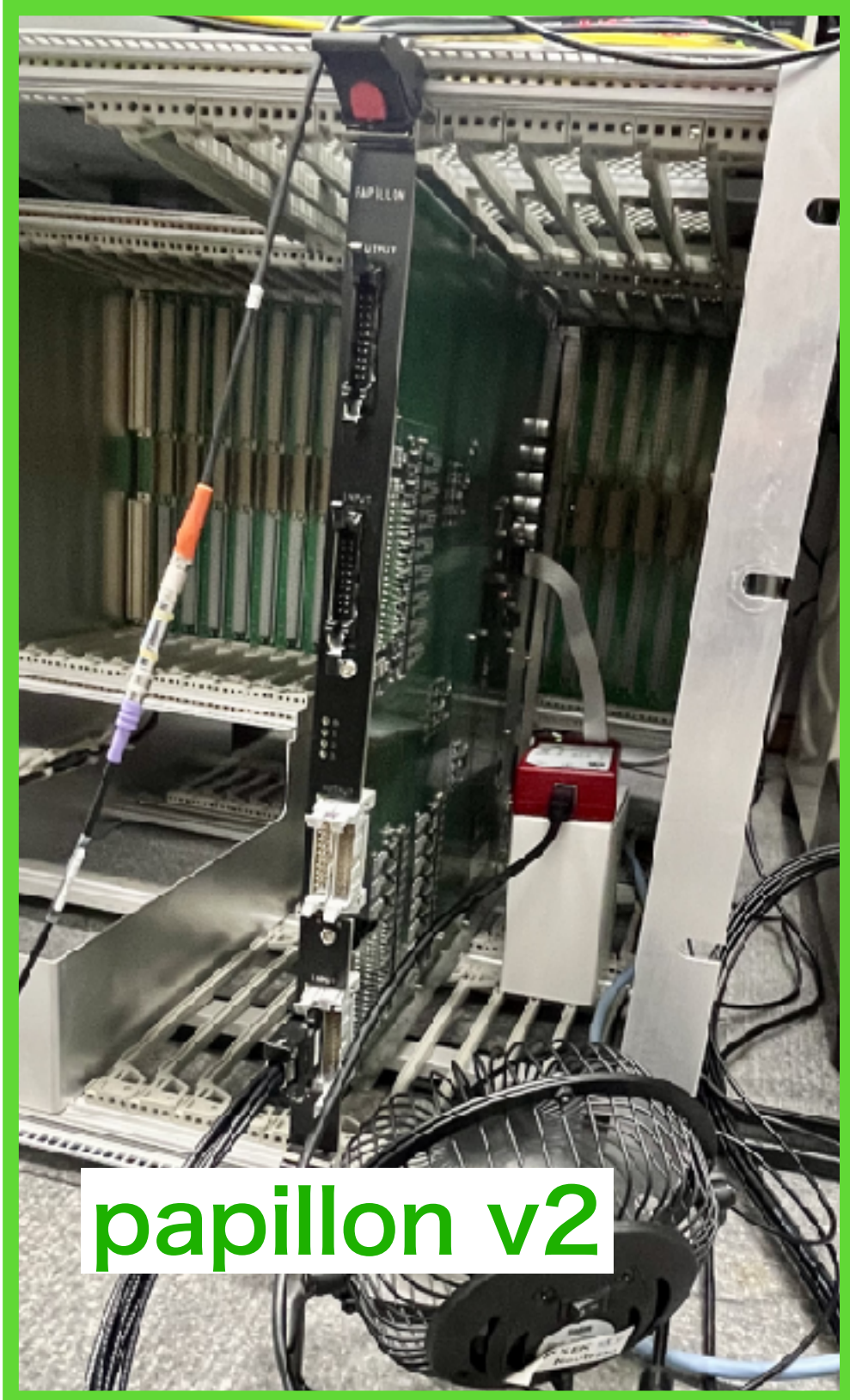
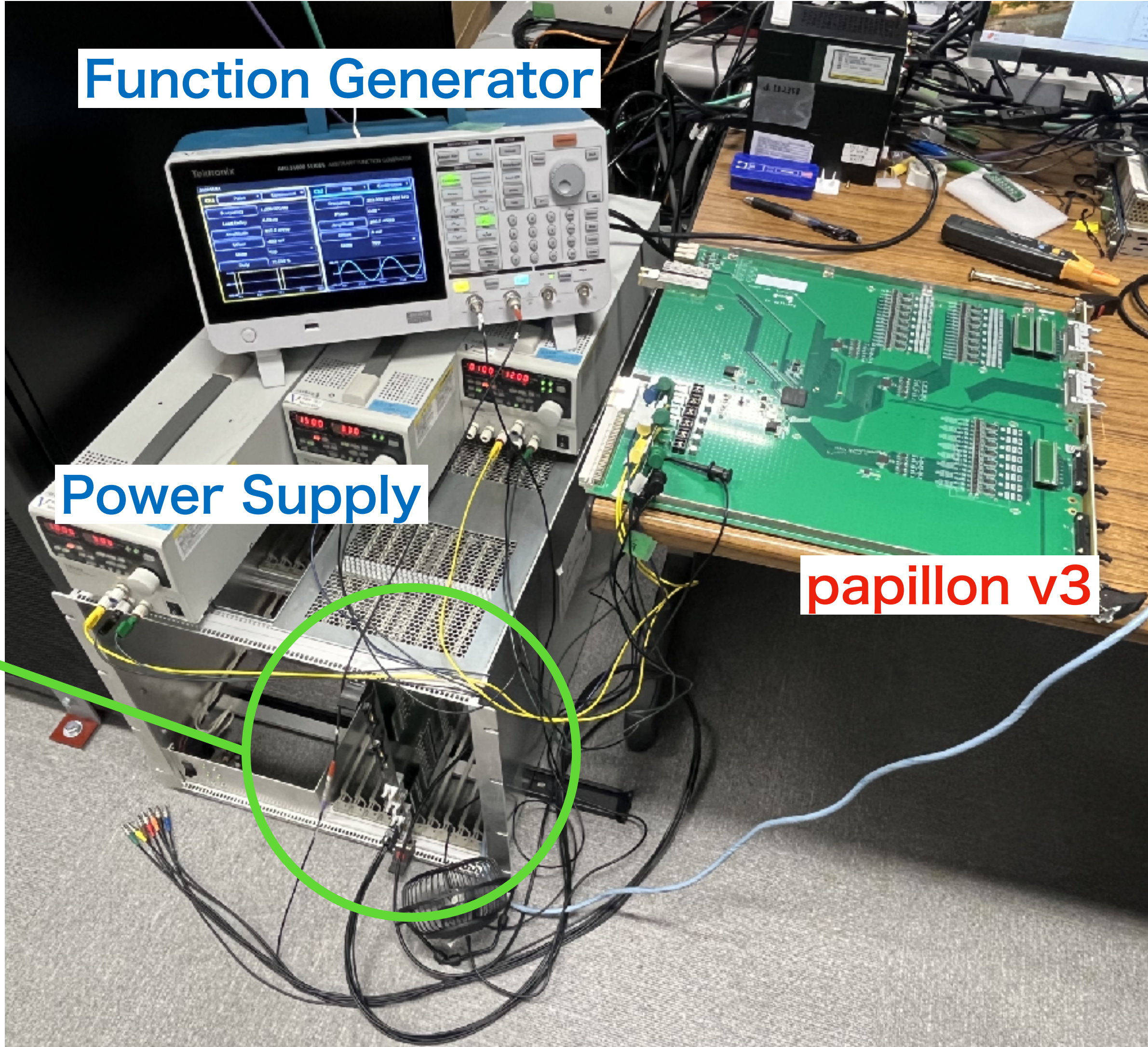

Input Signals:

- trigger in : 1 Hz NIM pulse
- signal in : sin wave
  - 500 ~ 1000 kHz
  - 200 ~ 400 mVpp

Waveform (input: 1 MHz, 400 mVpp)

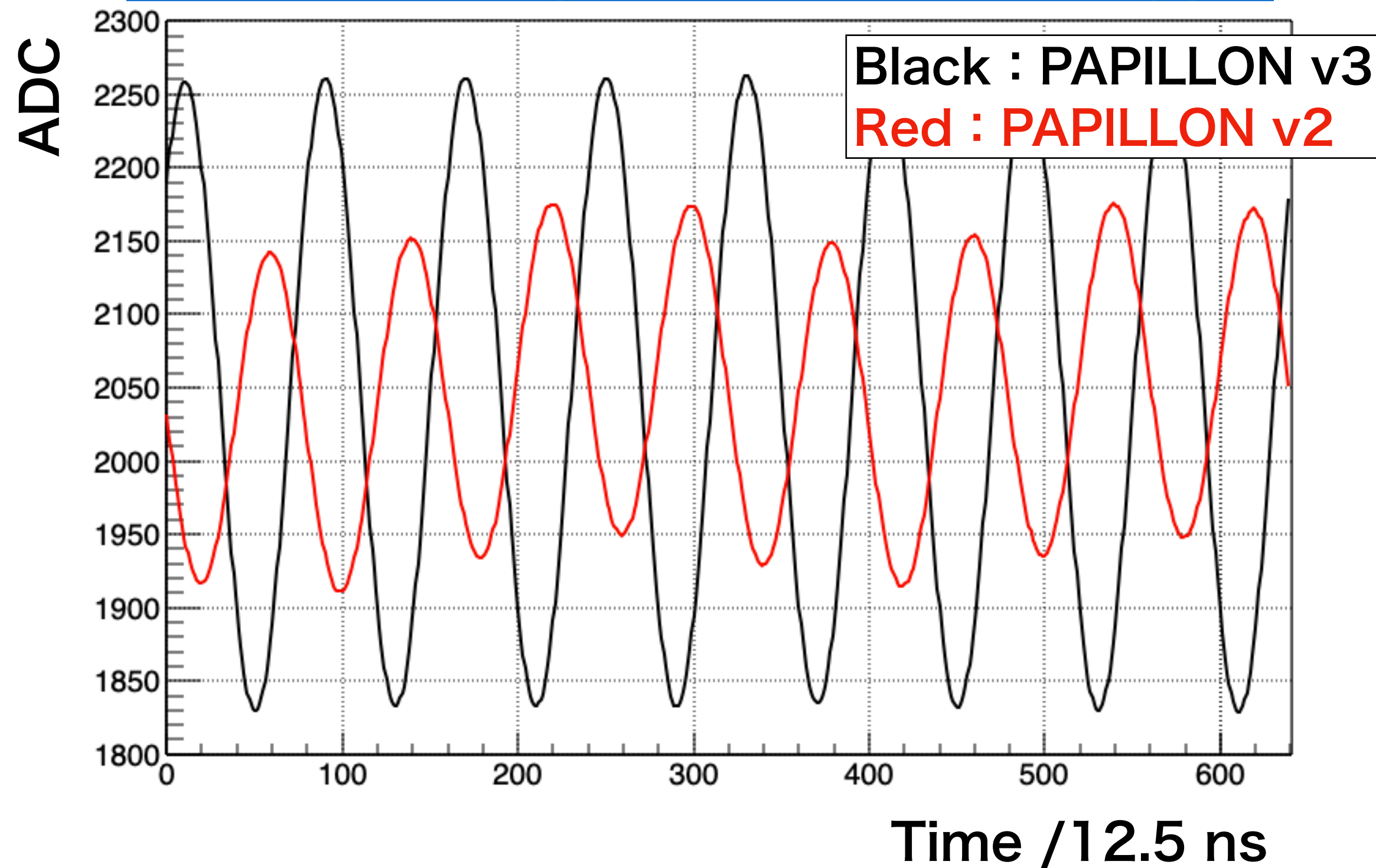

Amplitude Comparison

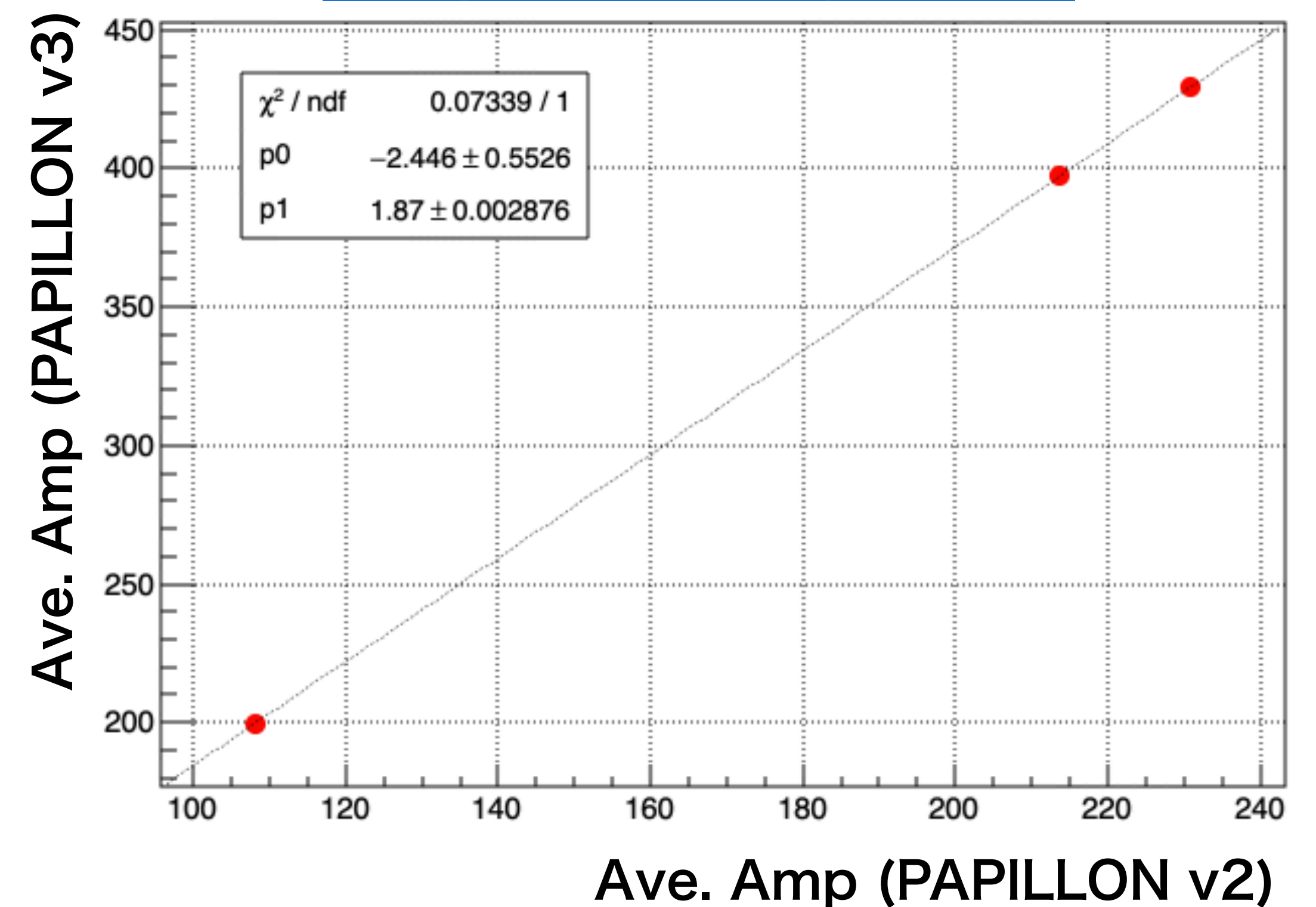

- For each event (8  $\mu\text{s}$  window), calculate the peak-to-peak value for each sine wave cycle and take the simple average.
- The amplitude ratio between v3 and v2 is  $(\text{Amp\_v3}) / (\text{Amp\_v2}) \approx 1.87$ .
- The result is slightly lower than the design expectation, but roughly consistent with expectations.

# Dual-SFP Operation Test

- **Slow-control side:** register access via RBCP (read/write of parameter values)

```
[RBCP>rd 0x0 4 ← read command
RBCP> Succeed in reading. (ID=0)
RBCP> 00000000: 20 26 02 03
```

>> Version information (2026/02/03) was successfully returned

```
==== setup_adc1.txt ====
[RBCP>- Write 0 to 0x10 (ID=0) ] write
RBCP> Succeed in reading. (ID=1) ] read
[RBCP> 00000010: 00
- Write 60 to 0x100 (ID=2)
[RBCP> Succeed in reading. (ID=3)
[RBCP> 00000100: 18
```

>> Initial parameters were successfully written to the registers

- **Data-transfer side:** a sine wave signal was input to the board for data acquisition

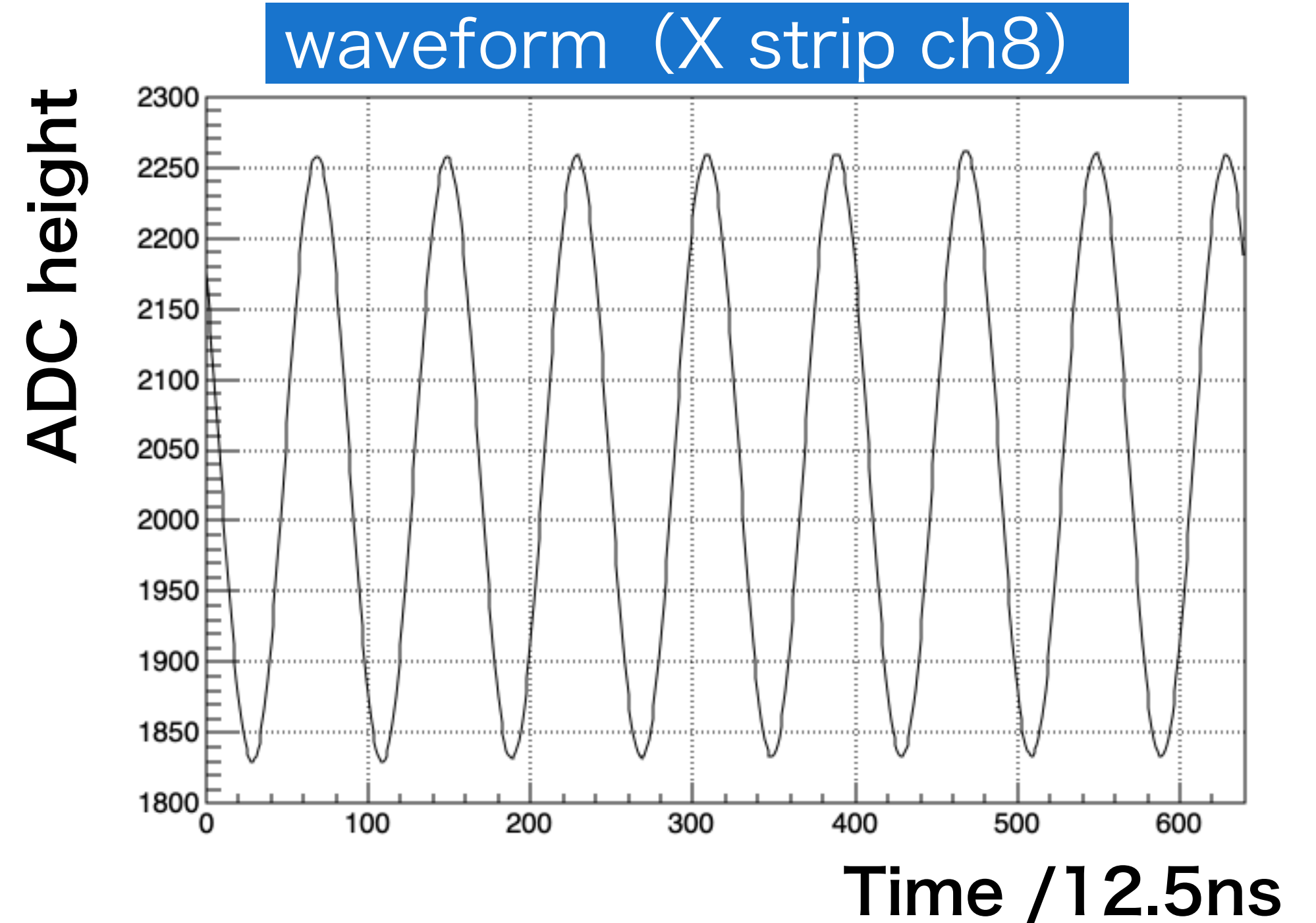

>> Waveform data were acquired without any issues

-> Dual-SFP implementation completed!

# PAPILLON BeamTest 2026.03.11 @NU1 24



# Waveform : DAQevent28

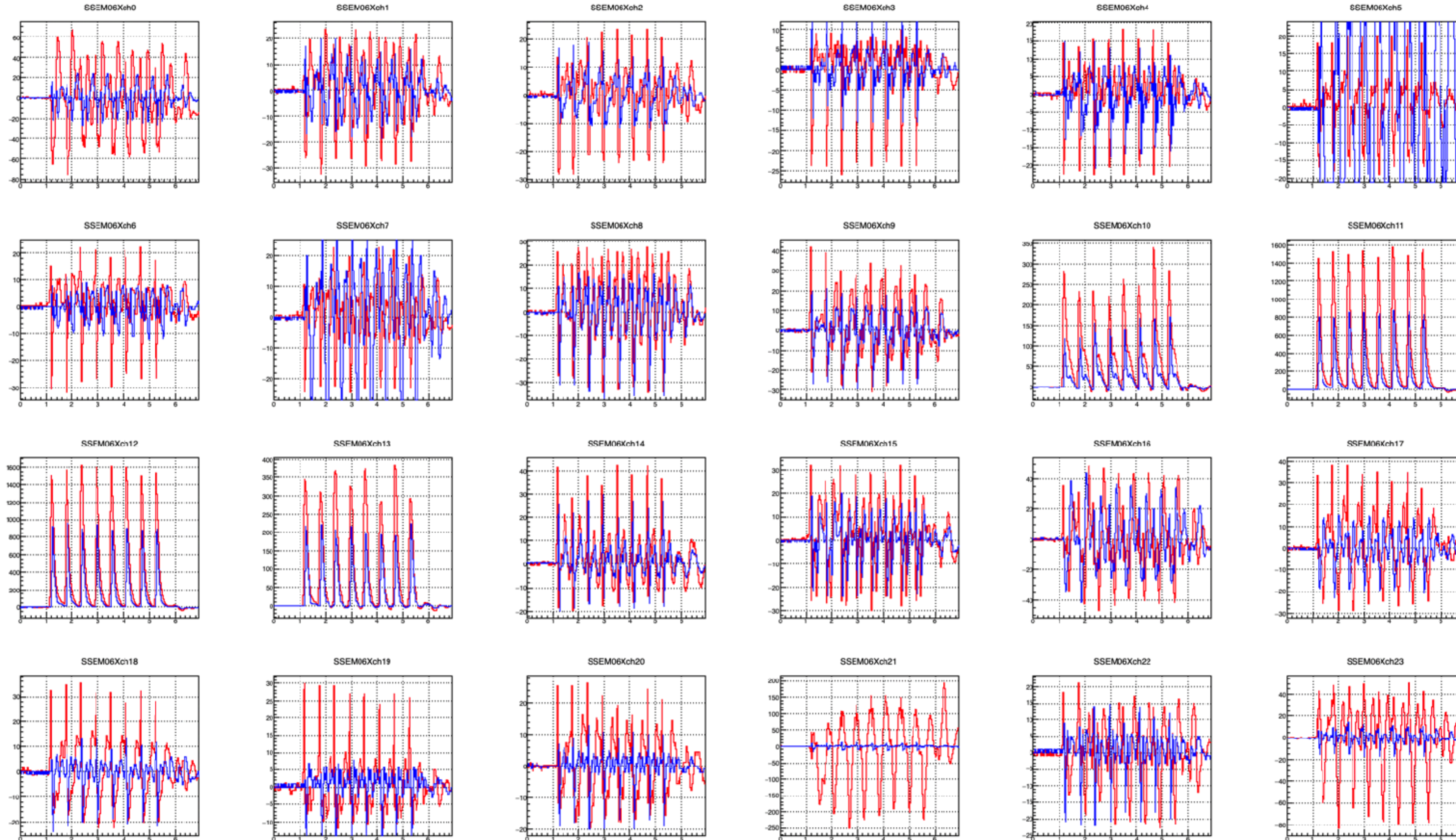

Red: COPPER  
Blue: PAPILLON