

Solar Neutrino Interaction Rate < 3.49 MeV in SK-IV

Alejandro Yankelevich

for the Super-Kamiokande Collaboration



The Solar Upturn

- The Mikheyev–Smirnov–Wolfenstein (MSW) effect, causes all ν_e to adiabatically convert to ν_2 .
- The required density increases with decreasing energy, so only vacuum oscillations below ≈ 1 MeV.
- The “upturn” in ν_e survival probability (P_{ee}) has not been observed due to high radioactive background.

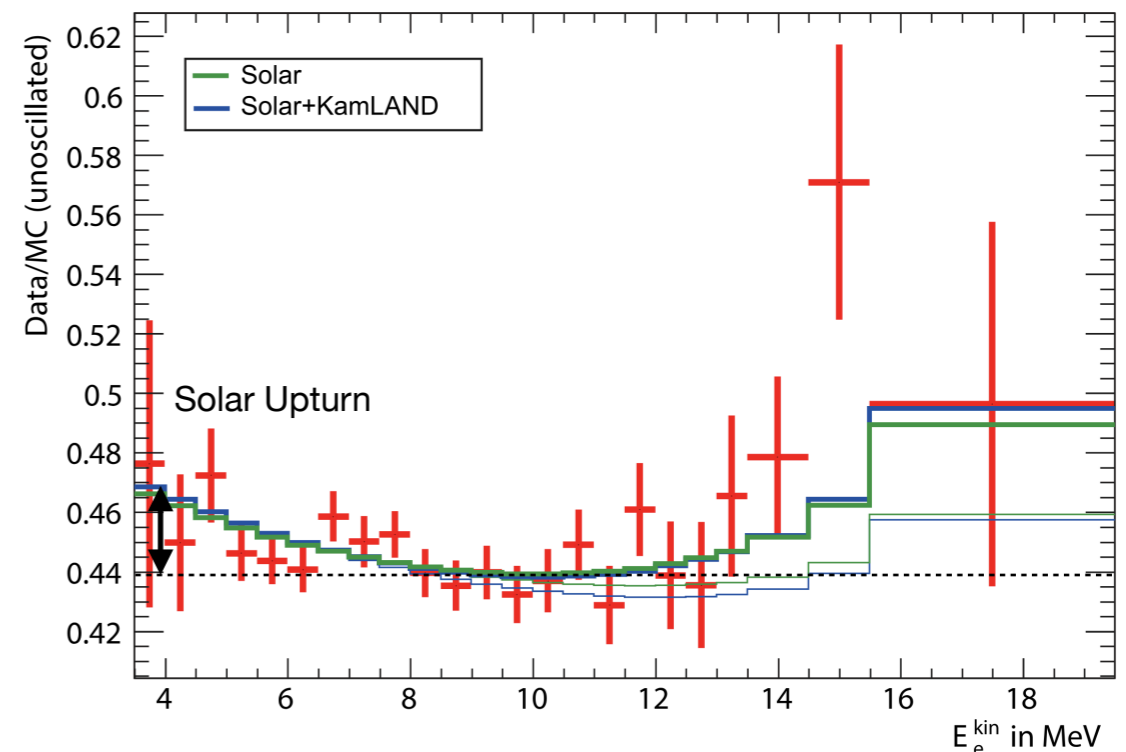
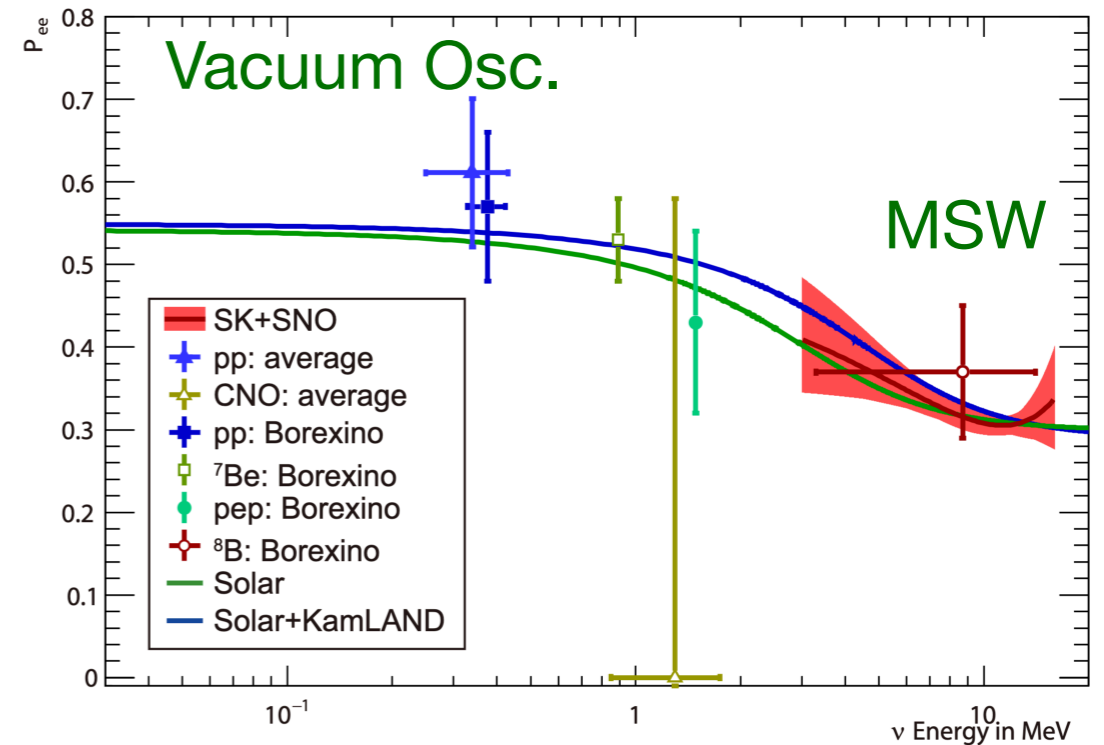

Super-Kamiokande

- 50 kton water Cherenkov detector 1 km under Mt. Ikeno, Japan.
- 11,129 20" PMTs detect Cherenkov light.
- Two independent triggers in DAQ: **software trigger** and **WIT**.
- Wideband intelligent trigger (WIT) is a system of CPUs that conducts online event reconstruction and triggering to preserve lower energy events.

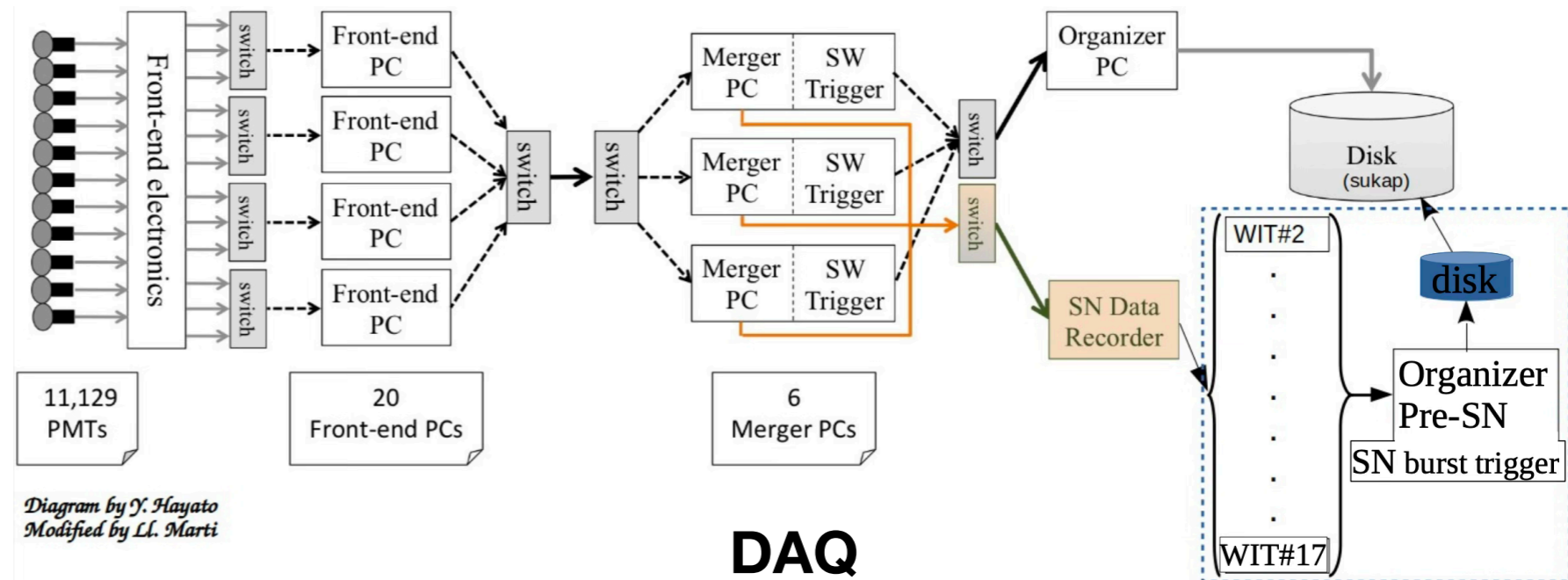
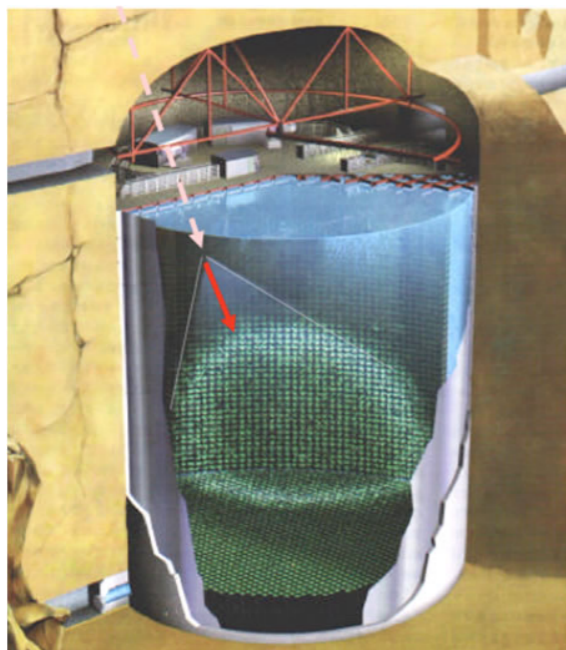
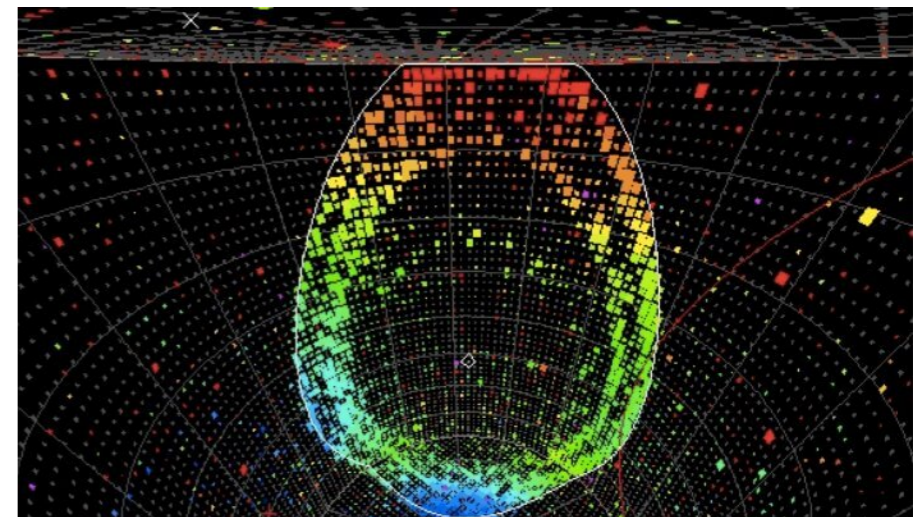
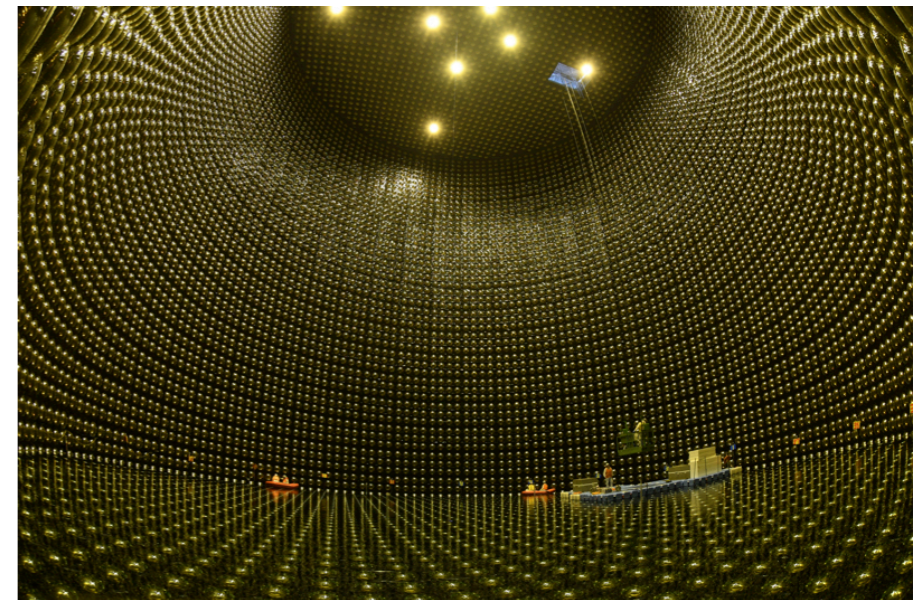

SK Solar Analysis

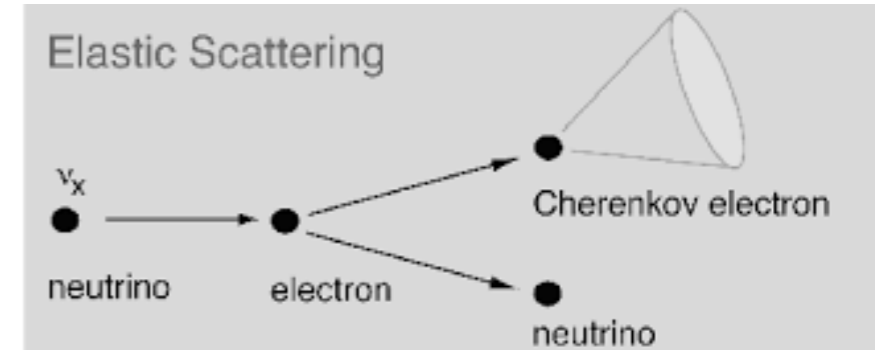

- As a water Cherenkov detector, Super-K observes ^8B solar neutrinos through elastic scattering on electrons.
 - Recoil electron preserves direction of neutrino. \rightarrow Can use direction to identify solar neutrinos.
- Most recent analysis uses SK I-IV (5805 days total, 2970 in SK-IV).
- SK+SNO: 2.1σ significance against flat ν_e survival probability.

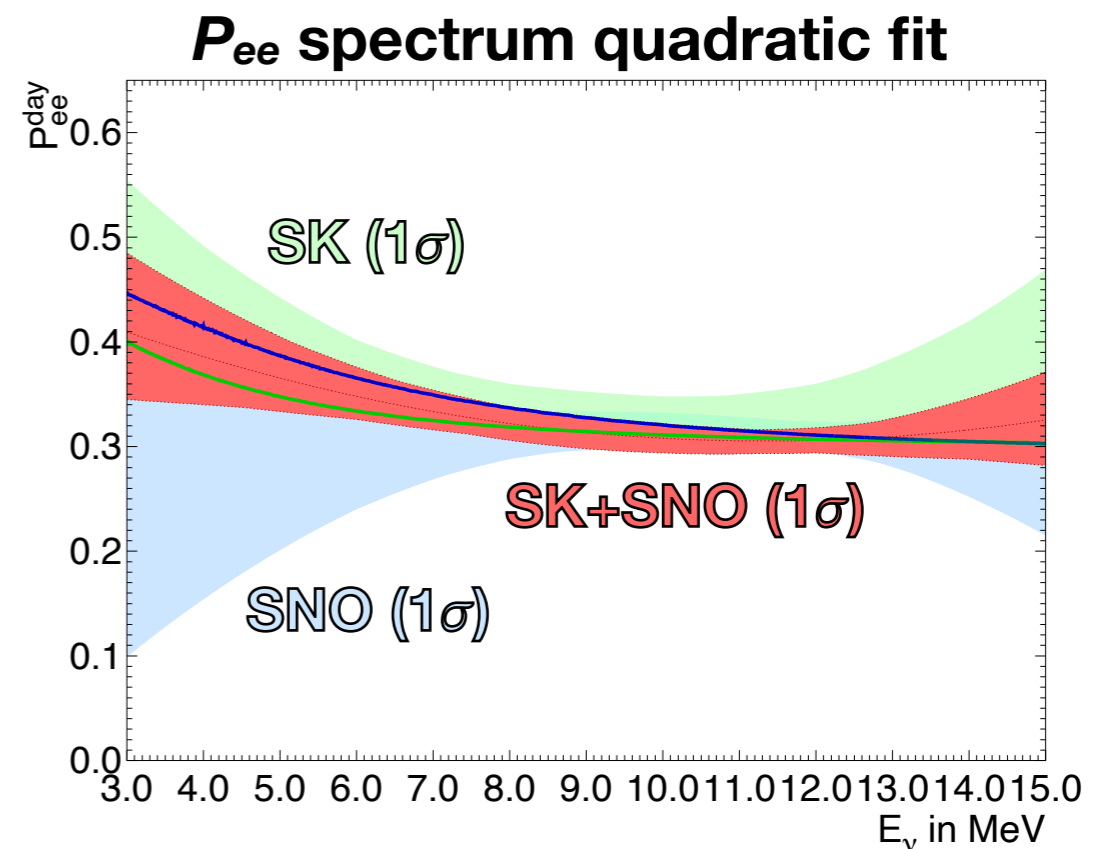
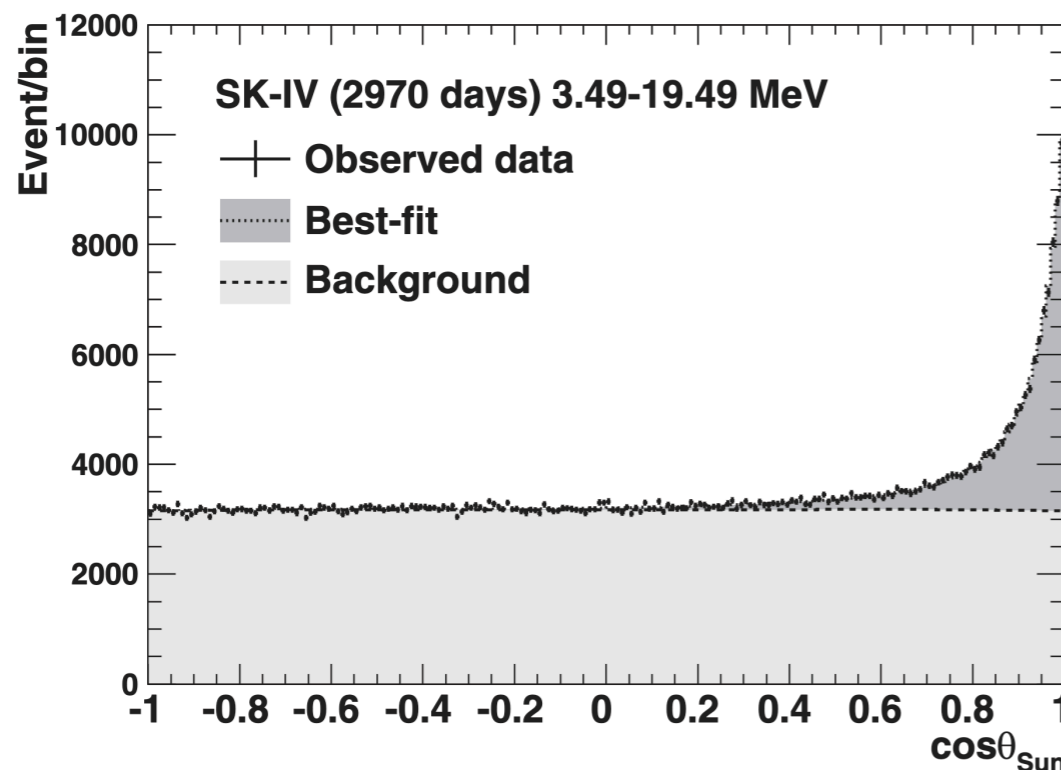

Sources of Background

- <6 MeV, radioactive impurities is largest background.
 - Radon gas from mine enters detector. ^{214}Bi β -decay (3.3 MeV Q-value).
 - Water current/temperature carefully controlled to create still, clean region.
 - PMT glass ^{208}Tl $\beta\gamma$ -decay (5.0 MeV Q-value, 2.2 MeV γ).
- >6 MeV, cosmic ray muon spallation radioactivity dominates.
 - Hadronic showers on ^{16}O produce ^{16}N , β -decay seconds later, meters away from track.

Radium-226 Decay Chain

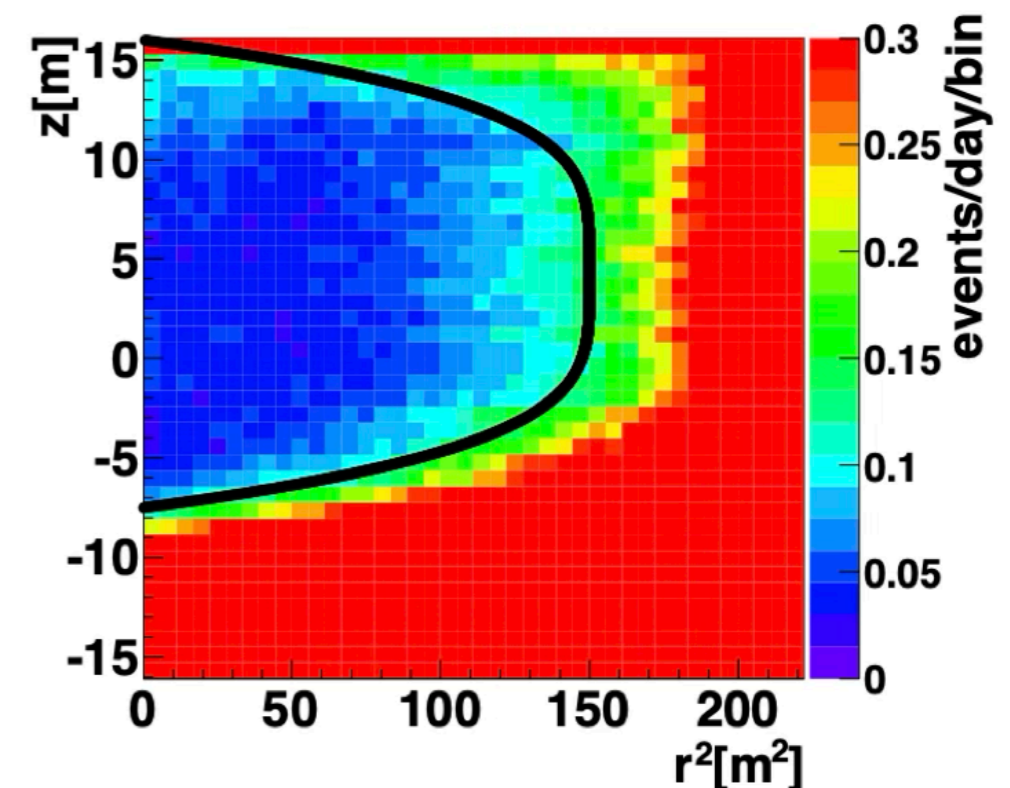
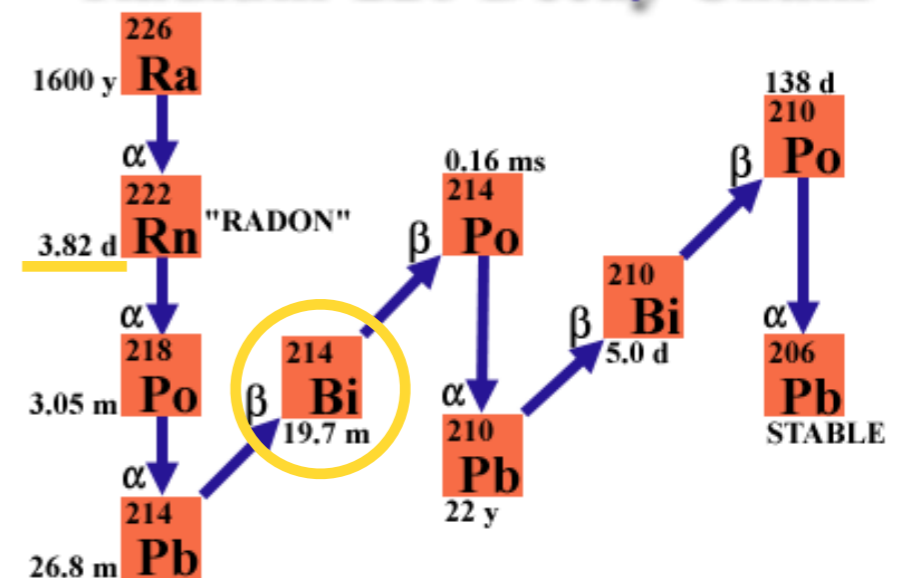

3.99 MeV - 4.49 MeV background distribution. Black line is tight fiducial volume cut.

Lowering Energy Threshold

- Several attempts to improve trigger efficiency near end of SK-IV.
 - Software trigger “SLE” (super low energy) threshold lowered from 34 hits to 31 hits.
 - July 2015: WIT system introduced.
- In <3.49 MeV WIT data after first reduction, $\sim 10^7$ radioactive background vs ≈ 5 solar events per day.
- Need further background rejection to observe signal in upturn region, $\approx 10x$ more per MeV.

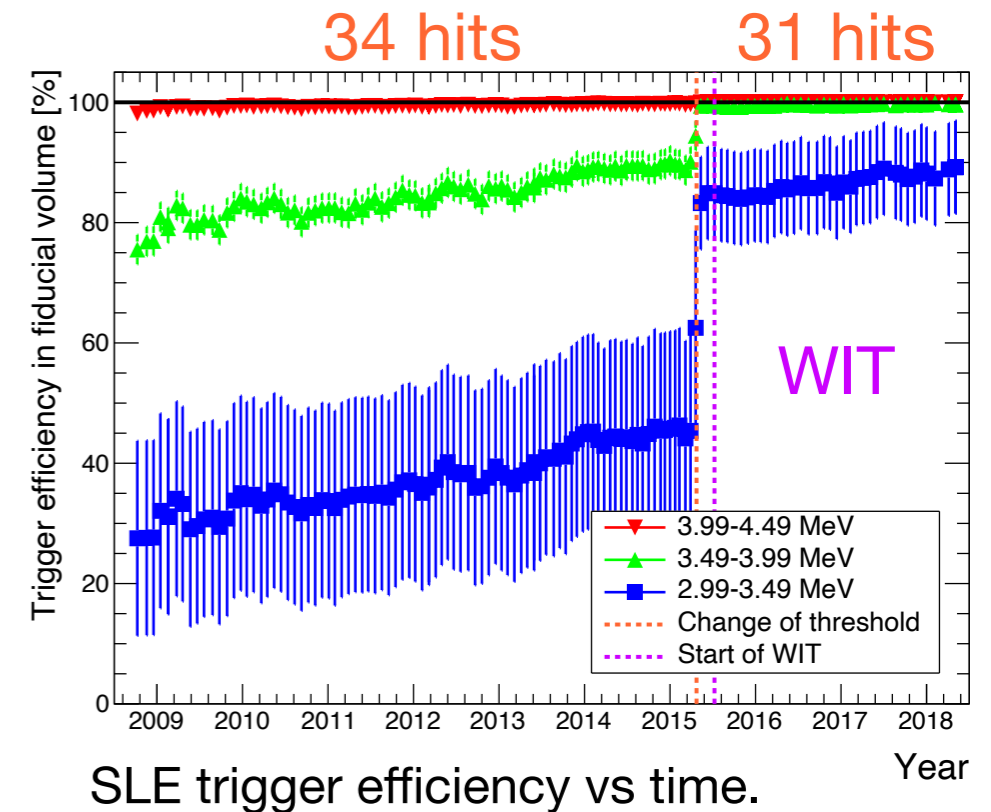

SLE trigger efficiency vs time.

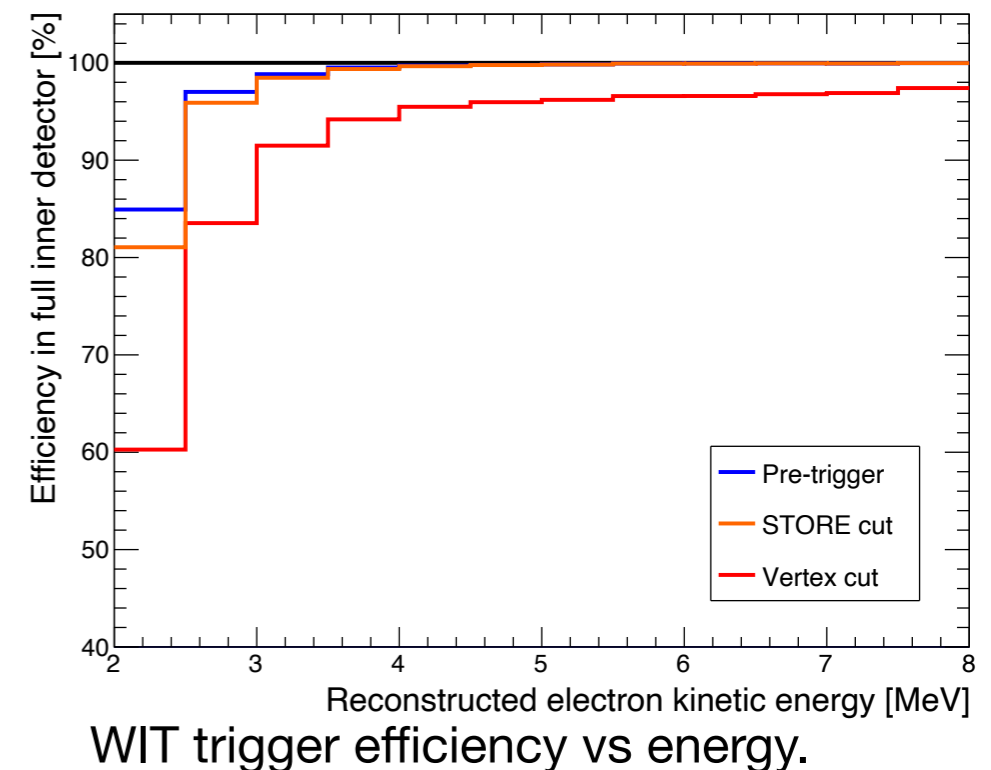

WIT trigger efficiency vs energy.

Machine Learning with PMT Hits

- Worked with water Cherenkov machine learning (WatChMaL) group to explore various ML methods for event selection.
- ResNet CNN [Phys. Sci. Forum 2023, 8\(1\), 63](#)
 - Trained on event display images.
 - 2D images distort 3D cylindrical geometry.
 - ResNet50 performed best.
- Graph Neural Networks
 - Trained on PMT positions in 3D connected by k-nearest neighbors.
 - DyEdCNN performed best. Learns optimal graph structure.

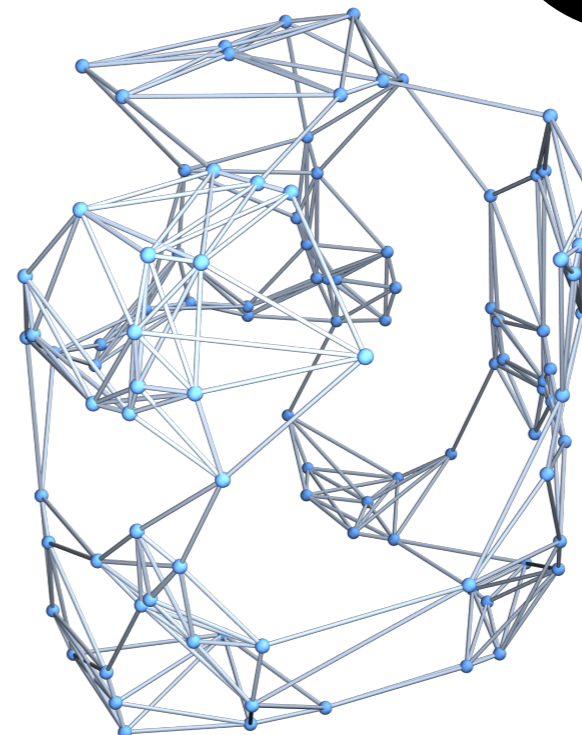
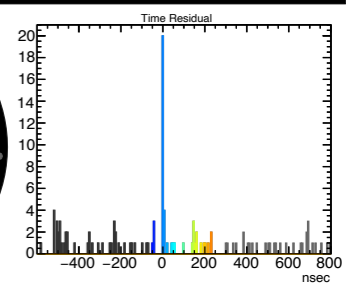
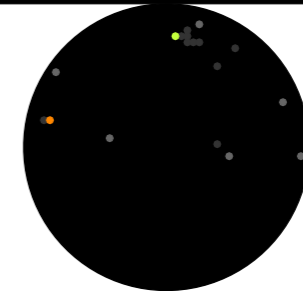
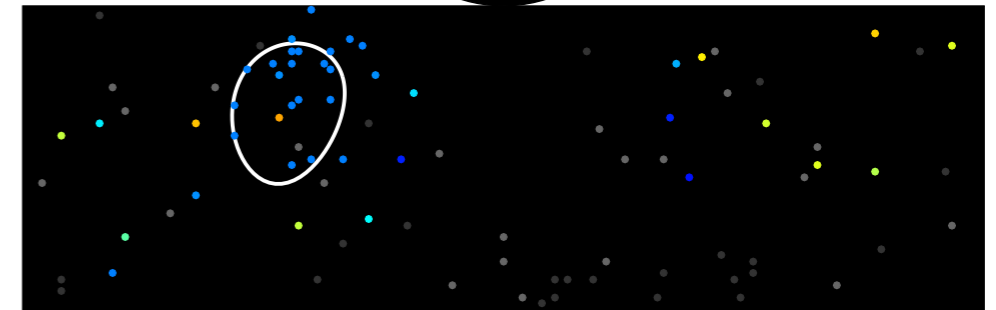
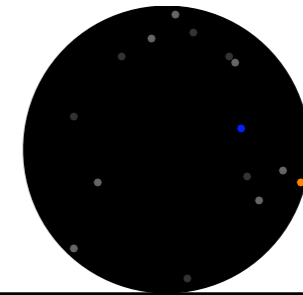

Solar MC event
5-nearest neighbor
graph

Machine Learning with Variables

- Trained boosted decision trees (BDTs) on reconstructed variables used in solar analysis.
 - 6.8x background rejection vs previous selection cuts in 2.49-3.49 MeV E_{kin} .
- Also tried “hybrid” methods with both PMT hit and variable inputs.
 - Feed network score to BDT.
 - DyEdCNN to embed PMTs, NN to embed variables, combine into NN for classification.

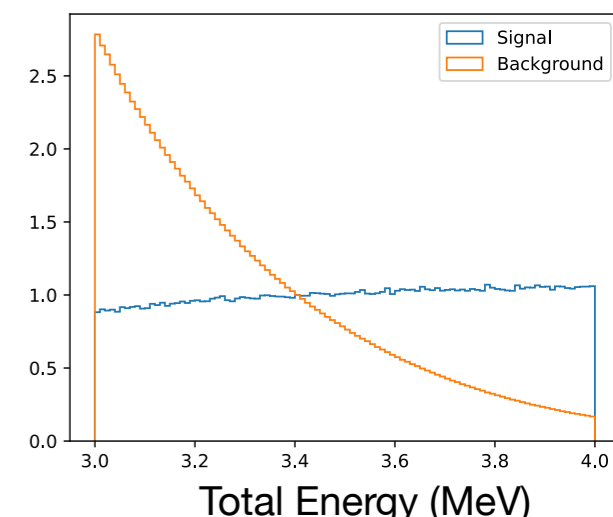
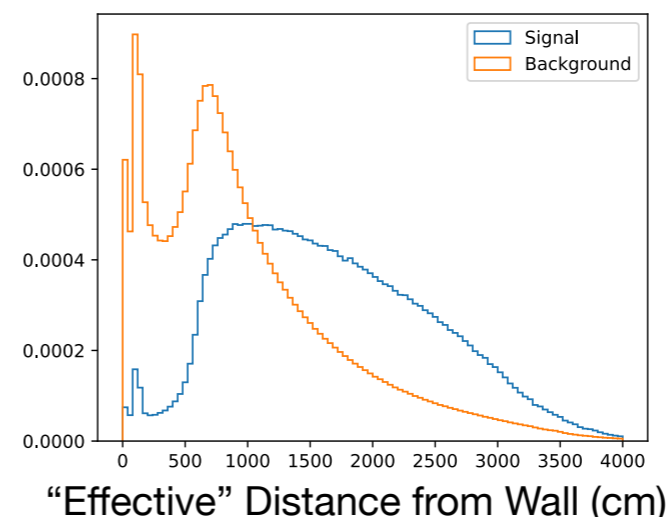
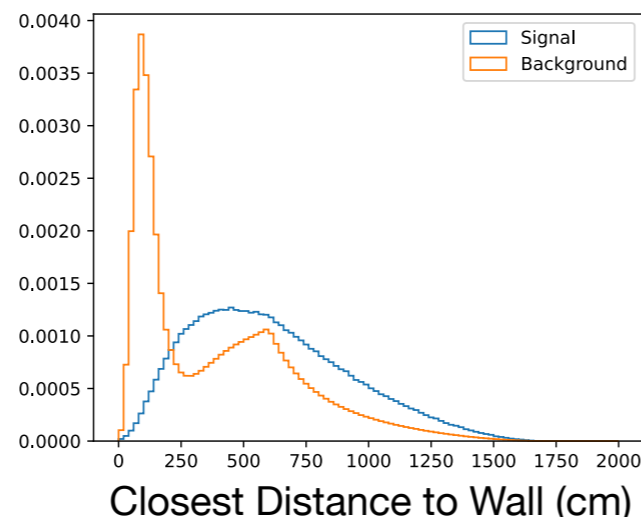
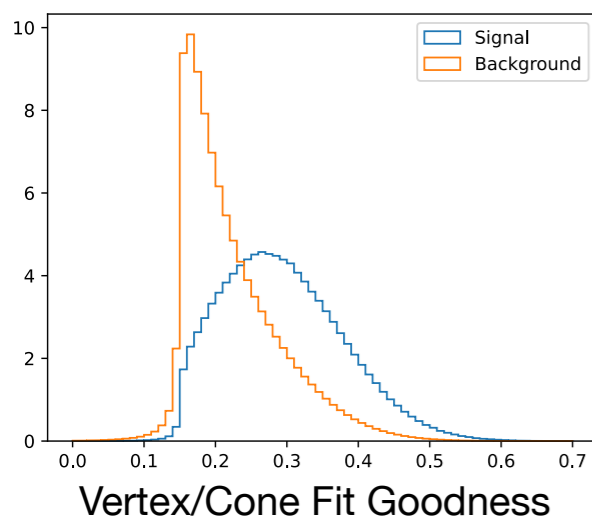
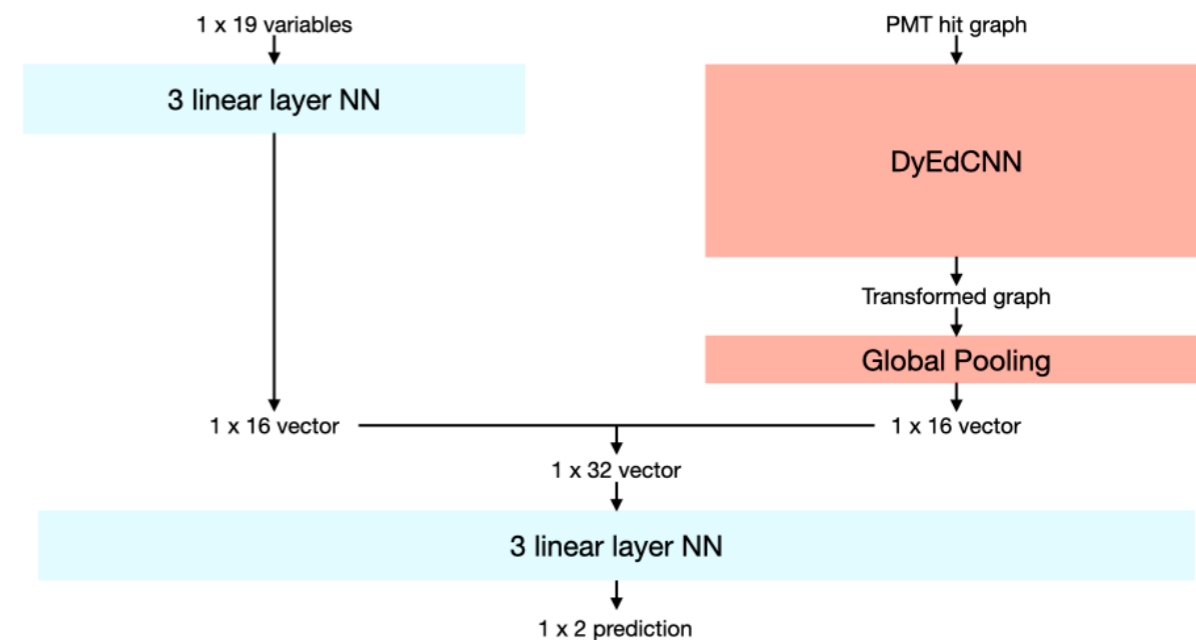
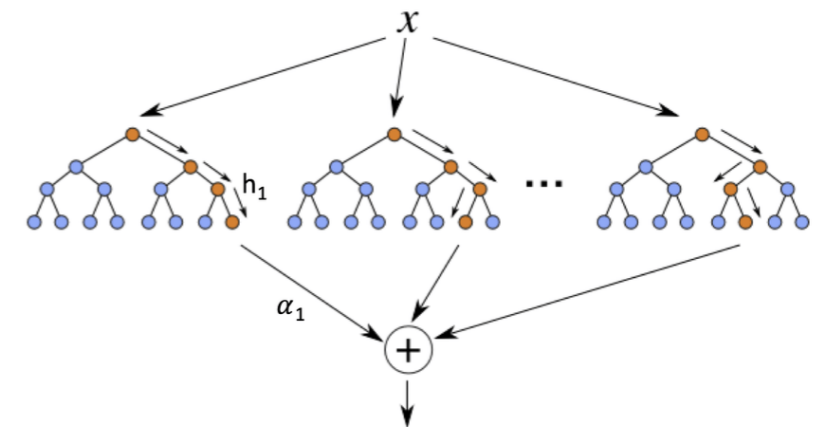

Final Selection / Signal Extraction

- 3 datasets to cover full 2970 day SK-IV phase.
 - **SLE 34-hit** period (2047 days)
 - **SLE 31-hit** period (305 days after excluding WIT)
 - **WIT** (618 days)
- Apply cosmic ray muon spallation cut and basic data quality cuts.
- Create “shapes” in $\cos(\theta_{\text{sun}}) = \hat{d} \cdot \hat{s}$ for signal and background.
 - Polynomial fit to solar MC distribution.
 - Data-driven background shapes with two alternative methods: **“Standard”** and **“Scramble”**.
- “Sofit” maximum likelihood fitter determines number of signal and background events based on data and shapes.

Systematic Uncertainties

- Background shape dominates systematic uncertainty.
- Compare two calculation methods. If S:B is small, small differences around solar peak have large effects on fit number of events.

Error Source	WIT	34-hit SLE
Background shape	11%	42%
Trigger efficiency	8.6%	16%
$g_t^2 - g_p^2$ fit goodness	2.1%	2.1%
Energy scale	4.5%	10.4%
Total uncorrelated	14%	45%
Total	15%	46%

Significant systematic error sources including energy-uncorrelated and energy-correlated errors.

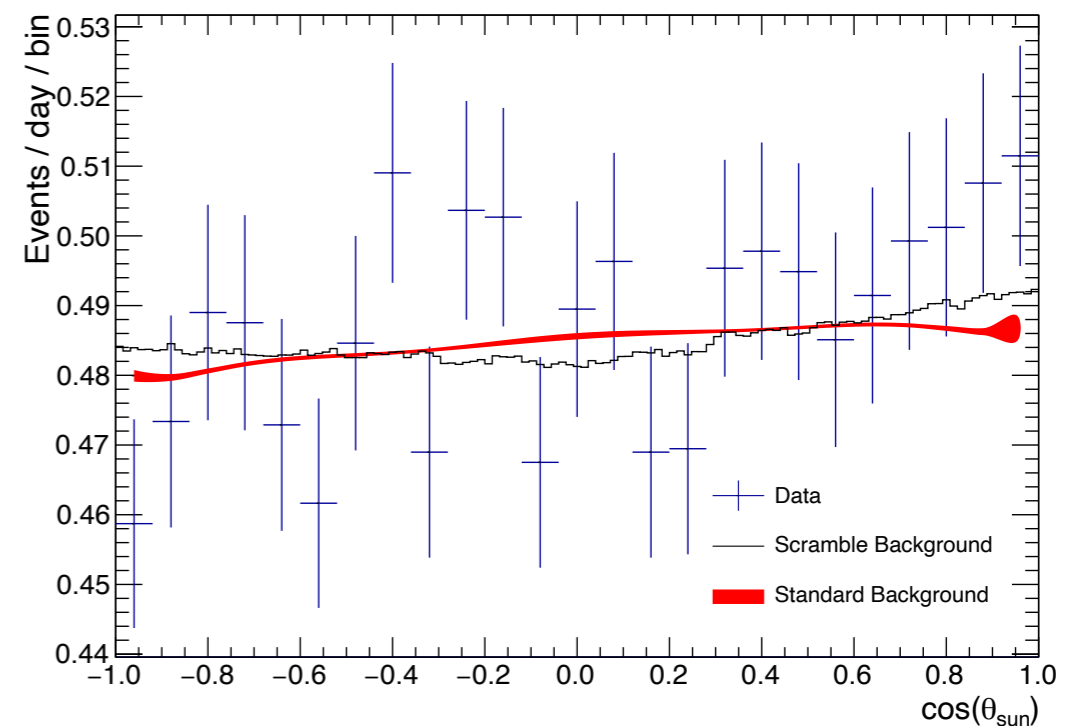

Example background shape method comparison. (34-hit SLE with multiple scattering goodness (MSG) 0.35 - 0.45)

Interaction Rate Results

“Multiple Scattering Goodness”
(slide 18)

Dataset	E_{kin} Bin	MSG Bin	Exp. (Unosc.)	Obs.	Obs./Exp.	
WIT	2.49–2.99 MeV	0–0.35	41	-45^{+46}_{-48}	$-1.1^{+1.1}_{-1.2}$	
	2.49–2.99 MeV	0.35–0.45	71	-13^{+48}_{-50}	$-0.18^{+0.68}_{-0.70}$	
	2.49–2.99 MeV	0.45–1	115	49^{+54}_{-53}	$0.42^{+0.47}_{-0.46}$	
	2.99–3.49 MeV	0–0.35	247	63^{+104}_{-102}	$0.25^{+0.42}_{-0.41}$	
	2.99–3.49 MeV	0.35–0.45	362	64^{+97}_{-96}	$0.17^{+0.27}_{-0.26}$	
	2.99–3.49 MeV	0.45–1	467	276^{+92}_{-90}	$0.59^{+0.20}_{-0.19}$	
	2.49–2.99 MeV	0–1	227	25^{+83}_{-81}	$0.11^{+0.37}_{-0.36}$	
	2.99–3.49 MeV	0–1	1077	$457^{+159}_{-157} \pm 69$	$0.425^{+0.148}_{-0.146} \pm 0.064$	2.66 σ
SLE 34-hit	2.99–3.49 MeV	0–0.35	230	85^{+90}_{-88}	$0.37^{+0.40}_{-0.38}$	
	2.99–3.49 MeV	0.35–0.45	356	151^{+88}_{-86}	$0.42^{+0.25}_{-0.24}$	
	2.99–3.49 MeV	0.45–1	506	30^{+83}_{-82}	$0.06^{+0.16}_{-0.16}$	
	2.99–3.49 MeV	0–1	1092	$213^{+141}_{-140} \pm 98$	$0.196^{+0.130}_{-0.128} \pm 0.090$	1.25 σ
SLE 31-hit	2.99–3.49 MeV	0–0.35	70	-61^{+48}_{-51}	$-0.86^{+0.68}_{-0.72}$	
	2.99–3.49 MeV	0.35–0.45	99	73^{+48}_{-46}	$0.73^{+0.49}_{-0.47}$	
	2.99–3.49 MeV	0.45–1	121	-8^{+41}_{-43}	$-0.07^{+0.34}_{-0.35}$	
	2.99–3.49 MeV	0–1	291	23^{+77}_{-74}	$0.08^{+0.26}_{-0.26}$	
WIT+34-hit	2.99–3.49 MeV	0–1	2169	$667^{+195}_{-198} \pm 143$	$0.307^{+0.091}_{-0.090} \pm 0.066$	2.76 σ

Measurement \pm stat. \pm syst.

Compare observed rate to expected without oscillations using SNO results.

Obs./Exp. = 0.44 for no upturn (1.20 σ deficit), 0.47 for SK best-fit (1.47 σ deficit).

Interaction Rate Results

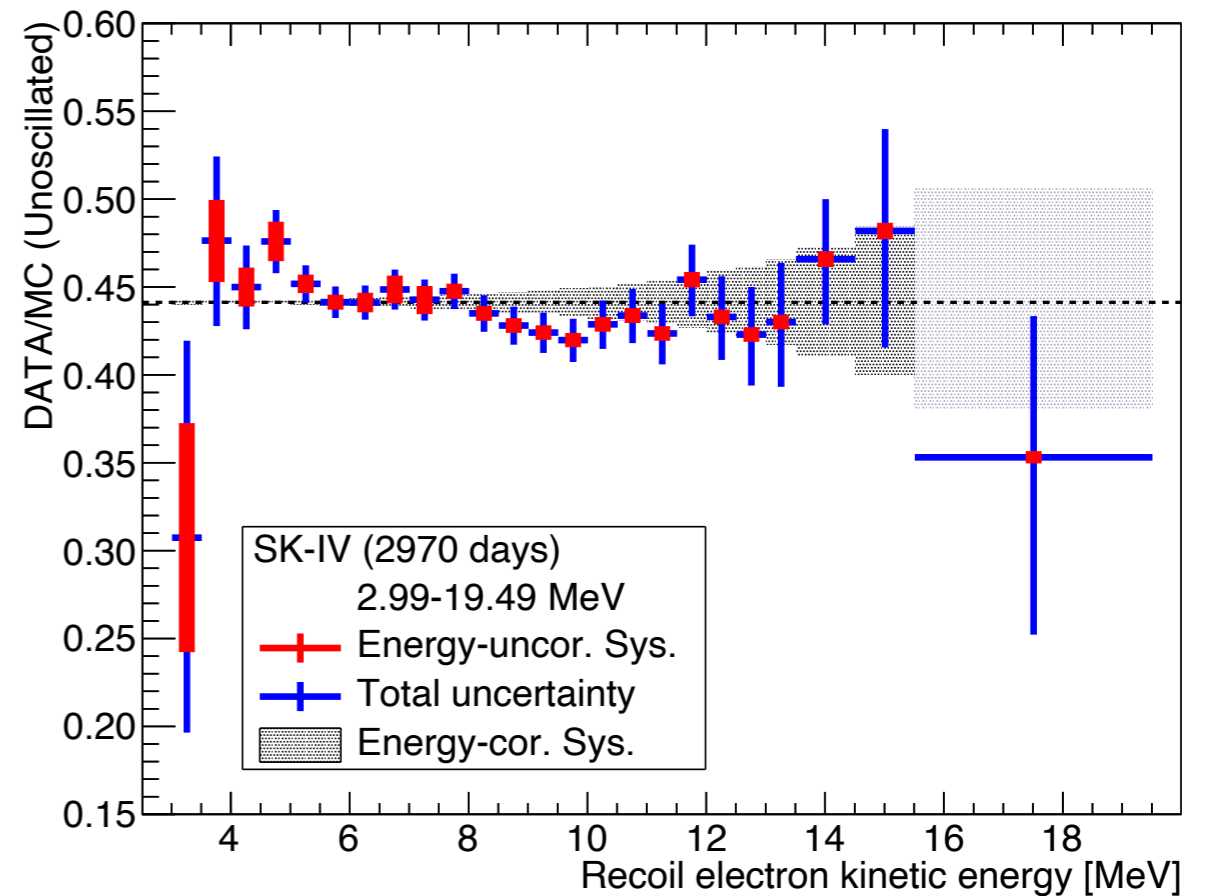
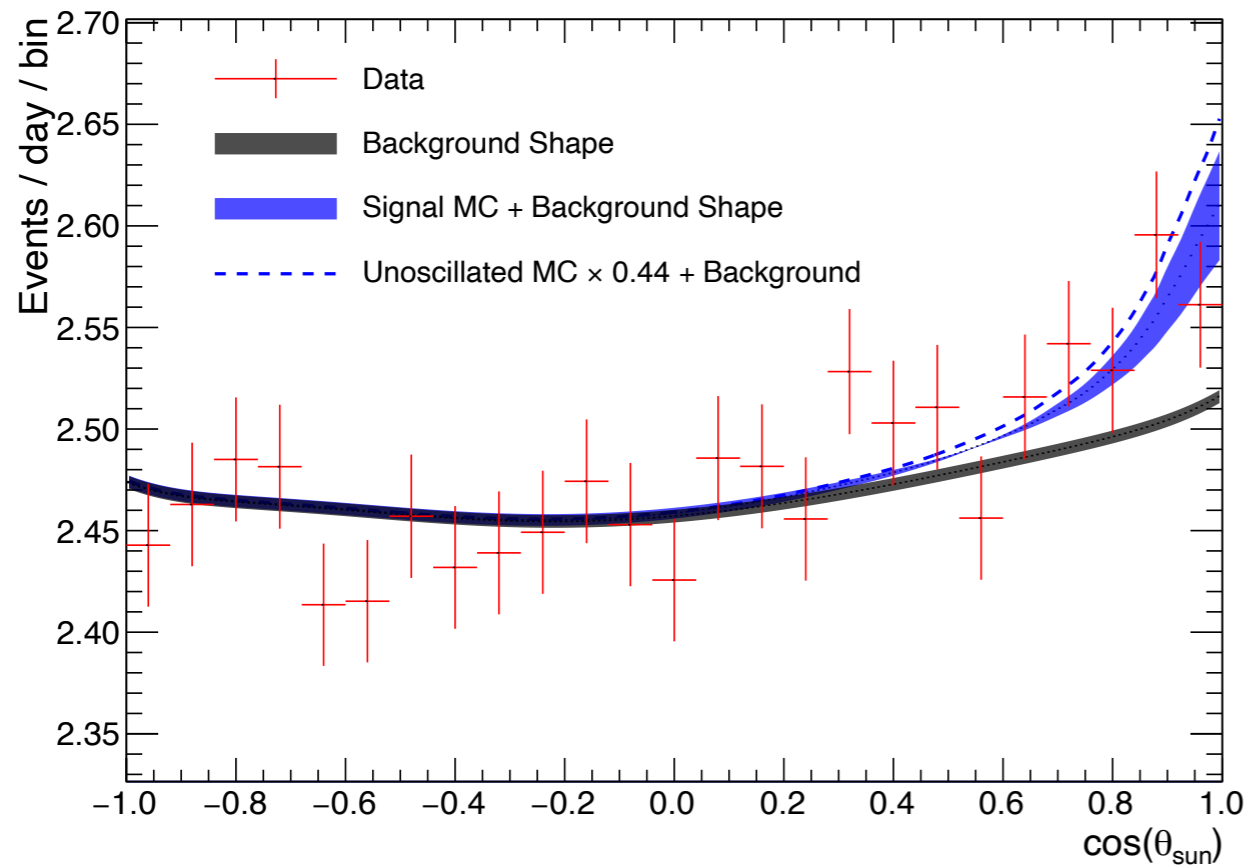

Compare observed rate to expected without oscillations using SNO results.
Obs./Exp. = 0.44 for no upturn (1.20σ deficit), 0.47 for SK best-fit (1.47σ deficit).

Summary and Future Sensitivity

- Applied BDT and incorporated WIT data to lower Super-K solar analysis energy threshold.
- 2.76σ solar neutrino signal indication in 2.99-3.49 MeV E_{kin} .
- Will need higher energy threshold (≈ 3.99 MeV) during later SK phases due to radioactive impurities in $\text{Gd}_2(\text{SO}_4)_3$.
- Primary goals of future SK solar analyses are day-night effect (currently 3.1σ) and *hep* neutrino search.

[Paper approaching publication](#), [arXiv.2512.19887](https://arxiv.org/abs/2512.19887)

Backup

Super-K Phases/Datasets

- SK-IV is longest phase with low background levels and improved electronics.
- SK-Gd starts with SK-VI. Gadolinium added to improve neutron detection (from $\bar{\nu}_e$ inverse beta decay).

	Phase	Duration	ID PMTs	Photocoverage	Gd (% w/w)
PMT implosion →	SK-I	Apr 1996 – Jul 2001 (1496 days)	11146	40%	0
New PMTs →	SK-II	Oct 2002 – Oct 2005 (791 days)	5182	19%	0
New elec. →	SK-III	Jul 2006 – Aug 2008 (548 days)	11129	40%	0
WIT starts July 2015 →	SK-IV	Oct 2008 – May 2018 (2970 days)	11129	40%	0
	SK-V	Feb 2019 – Jul 2020 (379 days)	11129	40%	0
Gd ₂ (SO ₄) ₃ Dissolved →	SK-VI	Jul 2020 – Jun 2022 (552 days)	11129	40%	0.01
Coil trouble, fixed →	SK-VII	Jun 2022 – Sep 2024 (596 days)	11129	40%	0.03
	SK-VIII	Sep 2024 – (505+ days)	11129	40%	0.03

Radioactive Decay Tables



WWW Table of Radioactive Isotopes

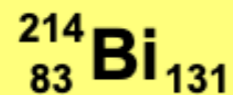

Half life: 19.9 m 4
Jp: 1-
S_n (keV): 4044 13
S_p (keV): 5.24E3 sy
Prod. mode: Naturally occurring

ENSDF citation: NDS 76,127 (1995)
Literature cut-off date: 1-Jun-1995
Author(s): Y.A. Akovali
References since cut-off: [²¹⁴Bi decay from 1995-98 \(NSR\)](#)

Decay properties:

Mode	Branching (%)	Q-value (keV)
b ⁻	99.979 1	3272 11
a	0.021 1	5616.8 10



WWW Table of Radioactive Isotopes

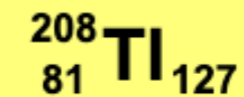

Half life: 3.053 m 4
Jp: 5(+)
S_n (keV): 3789 6
S_p (keV): 7.82E3 15
Prod. mode: Naturally occurring
 Fast neutron activation

ENSDF citation: NDS 47,797 (1986)
Literature cut-off date: 1-Dec-1985
Author(s): M.J. Martin
Update: 23-Apr-1997, R.B. Firestone
References since cut-off: [²⁰⁸Tl decay from 1997-98 \(NSR\)](#)

Decay properties:

Mode	Branching (%)	Q-value (keV)
b ⁻	100	5001.0 17

BDT Inputs

- nhit: number of PMT hits
- bsvertex[r, z]: position of offline reconstructed vertex via BONSAI (bs)
- bsdir[x,y,z]: direction unit vector
- bswall: closest distance from vertex to ID wall
- poswal[x,y,z]: position of intersection with wall along reverse of direction vector
- bseffwal: distance between bsvertex and poswal
- dtfv: closest distance to tight fiducial volume boundary
- val_poly: value of 2D polynomial fit to background vertex positions in r^2 and z
- bsenergy: reconstructed total event energy
- bsgood: goodness of vertex fit, higher for smaller PMT hit timing residuals
- bsdirks: hit pattern goodness, lower for better azimuthal symmetry of Cherenkov cone
- bsovaq: $bsgood^2 - bsdirks^2$
- bsclik: Smallest radius containing one-fifth of the hit PMTs, smaller for events originating at or near PMT glass
- MSG: Ariadne multiple scattering goodness (see next slide)

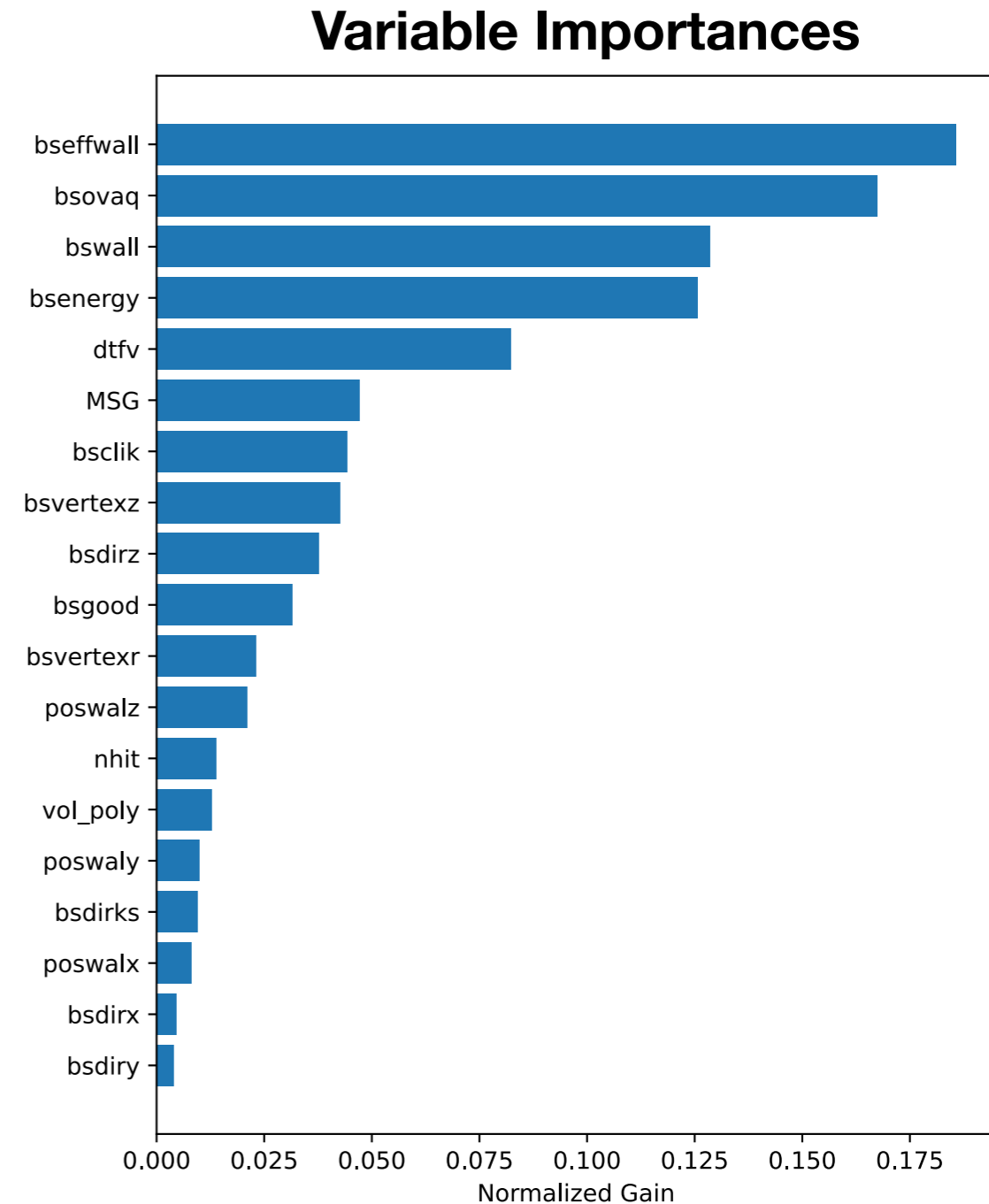

Multiple Scattering Goodness

- Quantifies alignment between candidate candidates.
- Lower energy electrons undergo less Coulomb scattering.
 - Fuzzier cones
 - Worse alignment

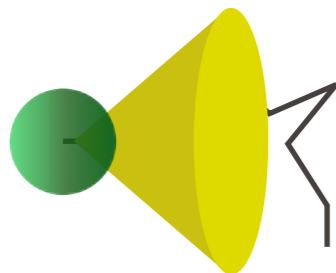

Low energy event
More scattering

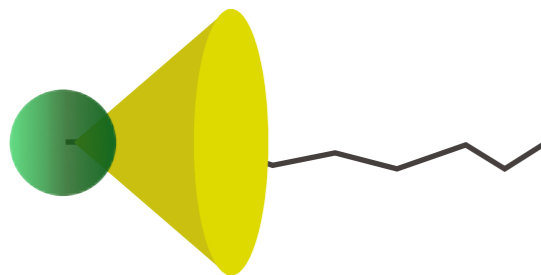

High energy event
Less scattering

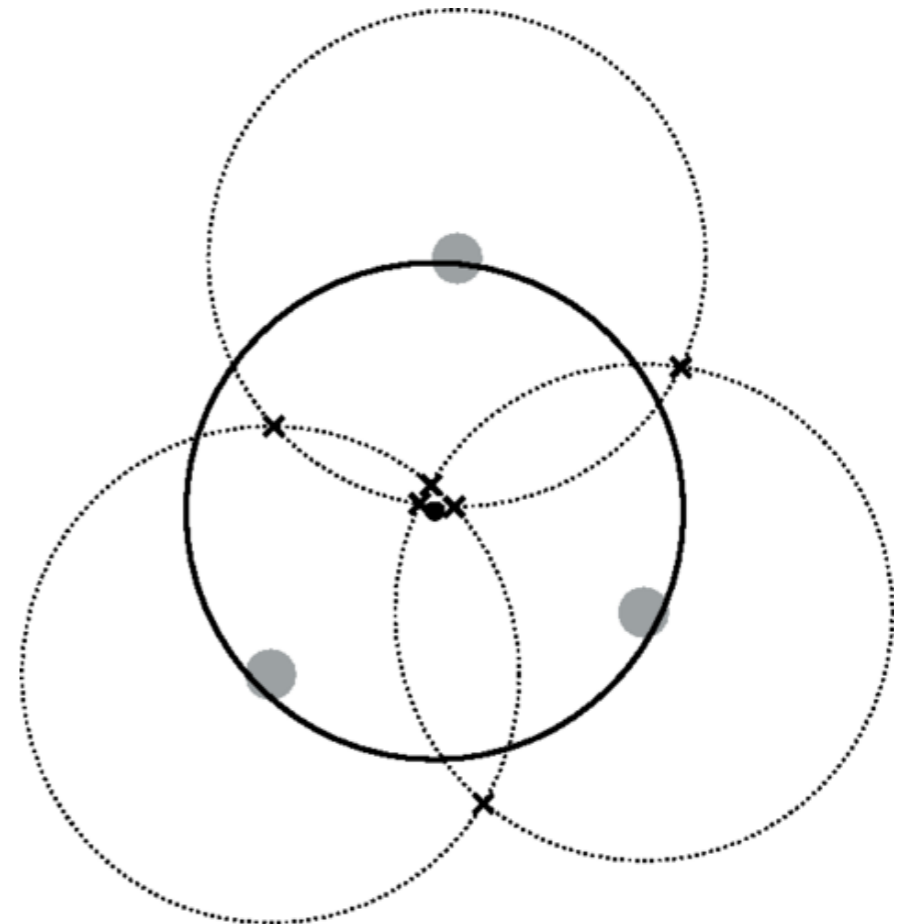

Schematic view of the event direction candidates used to calculate the multiple scattering goodness. The gray points represent PMT hits and the dotted circles surrounding them are the projections of the 42° cones centered around each hit. The black crosses give the intersection points of the cones. The vectors from the event vertex position to these intersection points are taken as event direction candidates. The black dot shows the event best fit direction and the black solid circle is the projection of its Cherenkov cone onto the inner detector wall. The intersections will cluster around the event direction.

ML Methods Performance

- All ML methods outperform existing solar analysis cuts.
- Hit-input methods perform well for large regions of ROC curve, but not low acceptance region.
- BDT matches or exceeds other methods in low acceptance region.

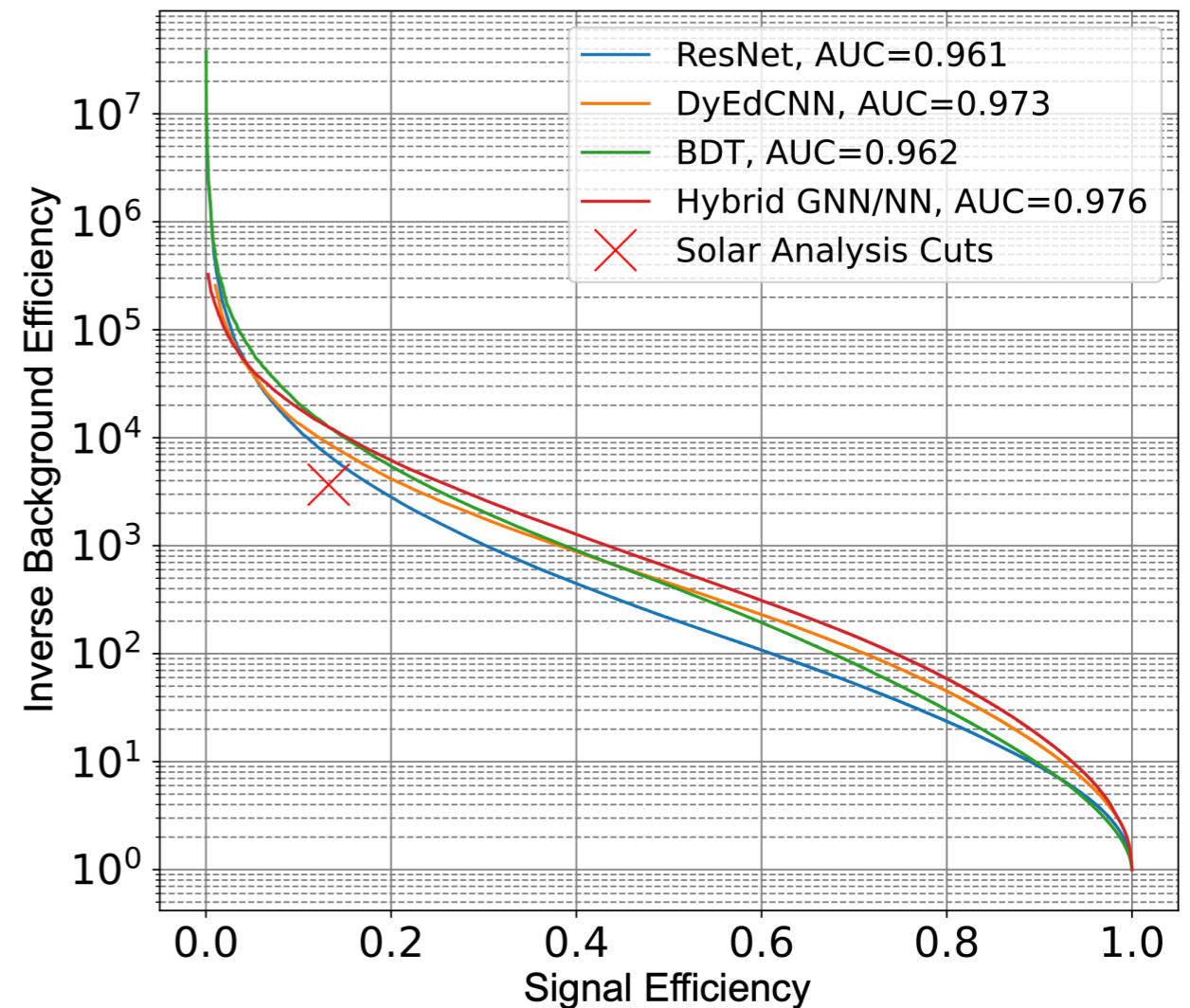

Background Shape Calculation

- “Shapes” are predicted $\cos(\theta_{\text{sun}}) = \hat{d} \cdot \hat{s}$ distributions for signal and background.
- Signal shape is polynomial fit to solar MC.
- Two data-driven methods for background shape:
 - Scramble: $\cos(\theta_{\text{sun}}^{ij}) = \hat{d}_i \cdot \hat{s}_j$ for all possible pairs of event direction \hat{d}_i and solar direction \hat{s}_j in sample.
 - Standard: Polynomial fits to $\cos(\theta)$, $\phi \rightarrow$ toy MC \rightarrow second fits \rightarrow project to $\cos \theta_{\text{sun}}$

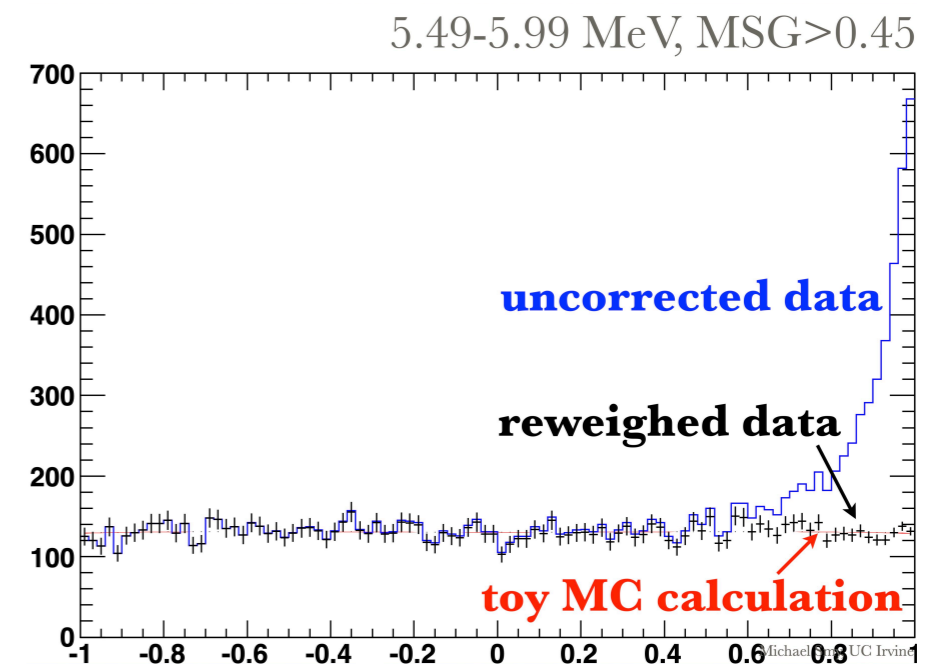
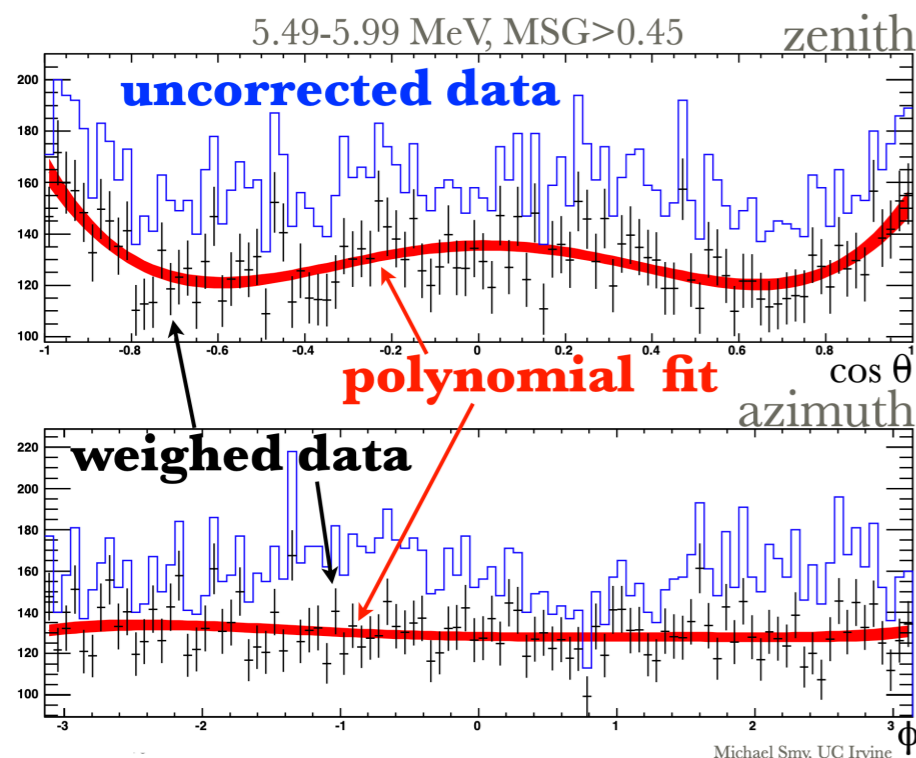

Adapting Systematics Calculations

- SK solar analysis assigns systematic uncertainty to each variable used for cuts by comparing variable in Data vs MC with calibration source.
 - Apply Data-MC difference to solar MC variable and observe efficiency change.
 - For BDT-based selection, apply same shift to BDT inputs and observe BDT output cut efficiency change.
- Extend existing energy-correlated uncertainty table to 2.49 MeV.
 - For energy spectrum fit: use as-is.
 - For solar interaction rate measurement: use above method for energy scale error on BDT energy input, apply same shifts to bin boundaries, assign larger of two effects.

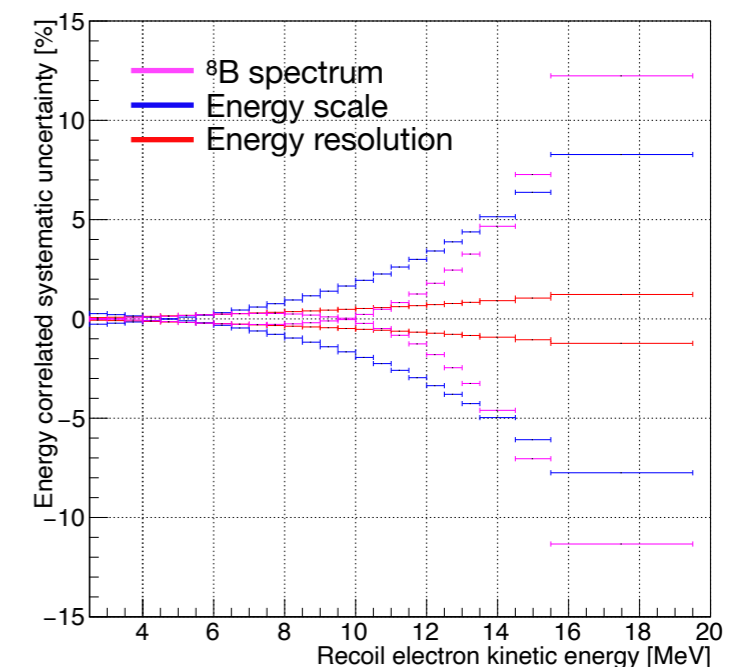
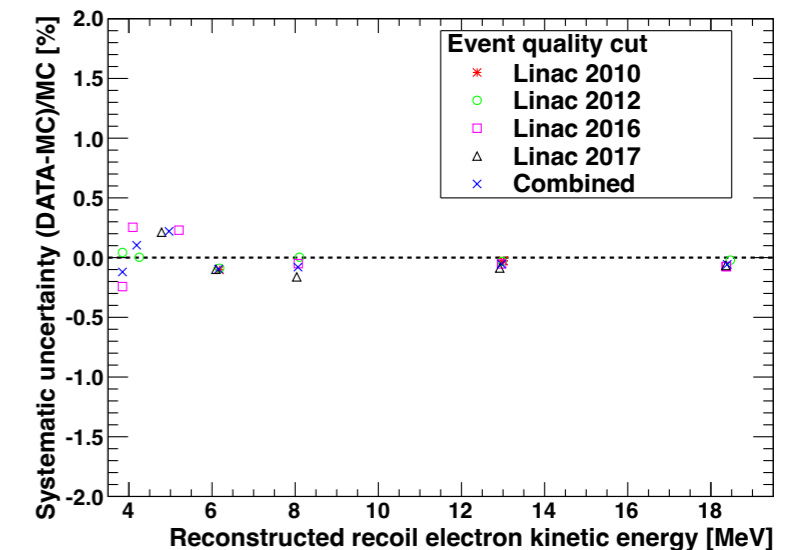

Shift method	WIT	34-hit	31-hit
Shift BDT input up	3.7%	4.0%	3.9%
Shift BDT input down	-3.6%	-3.9%	-4.0%
Shift final evt. E up	-4.4%	-9.4%	-6.2%
Shift final evt. E down	4.5%	10.4%	6.1%
Shift both up	-0.7%	-6.3%	-2.1%
Shift both down	0.9%	5.8%	2.5%

Dataset Solar Angle Distributions

WIT 2.49 MeV < E_{kin} < 2.99 MeV

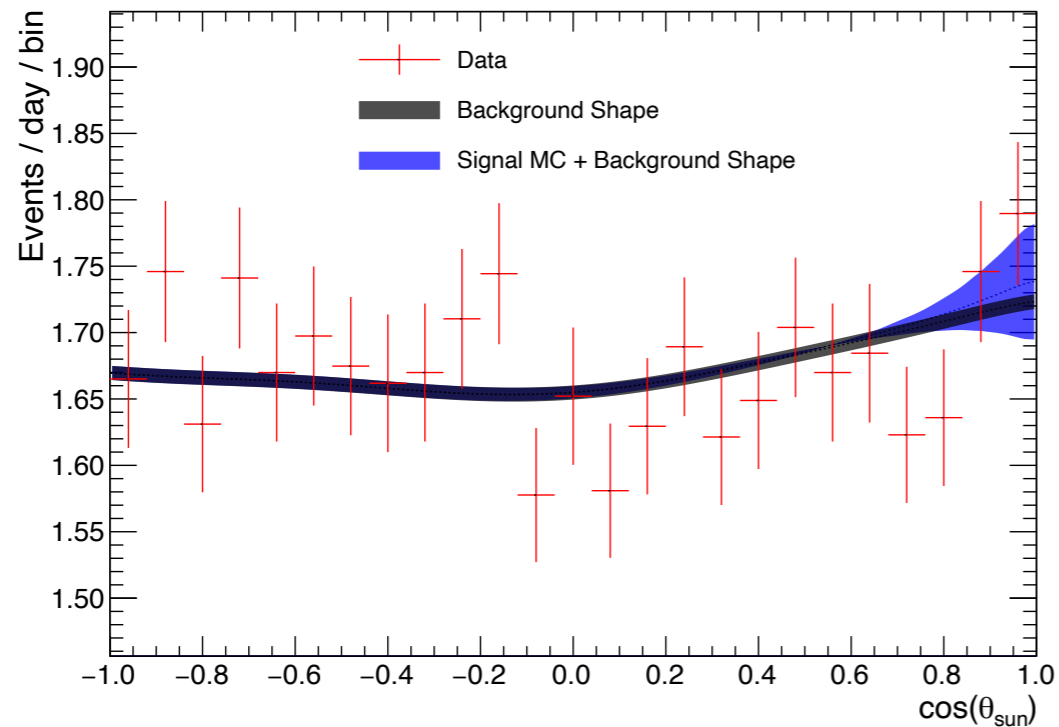

WIT 2.99 MeV < E_{kin} < 3.49 MeV

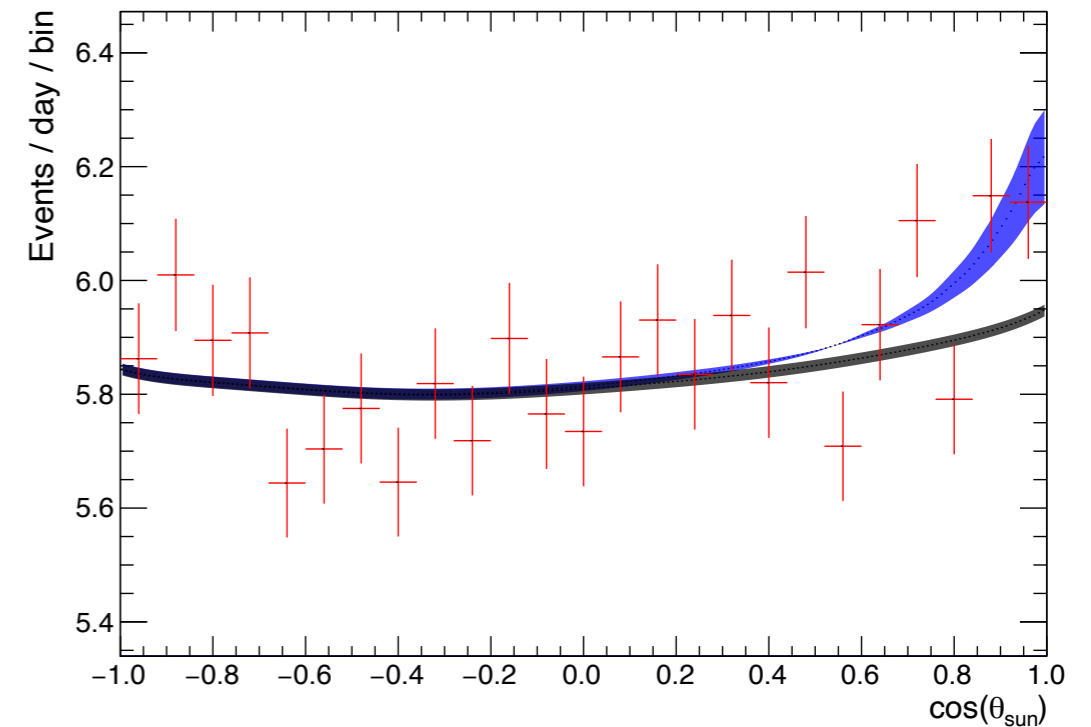

SLE 34-hit 2.99 MeV < E_{kin} < 3.49 MeV

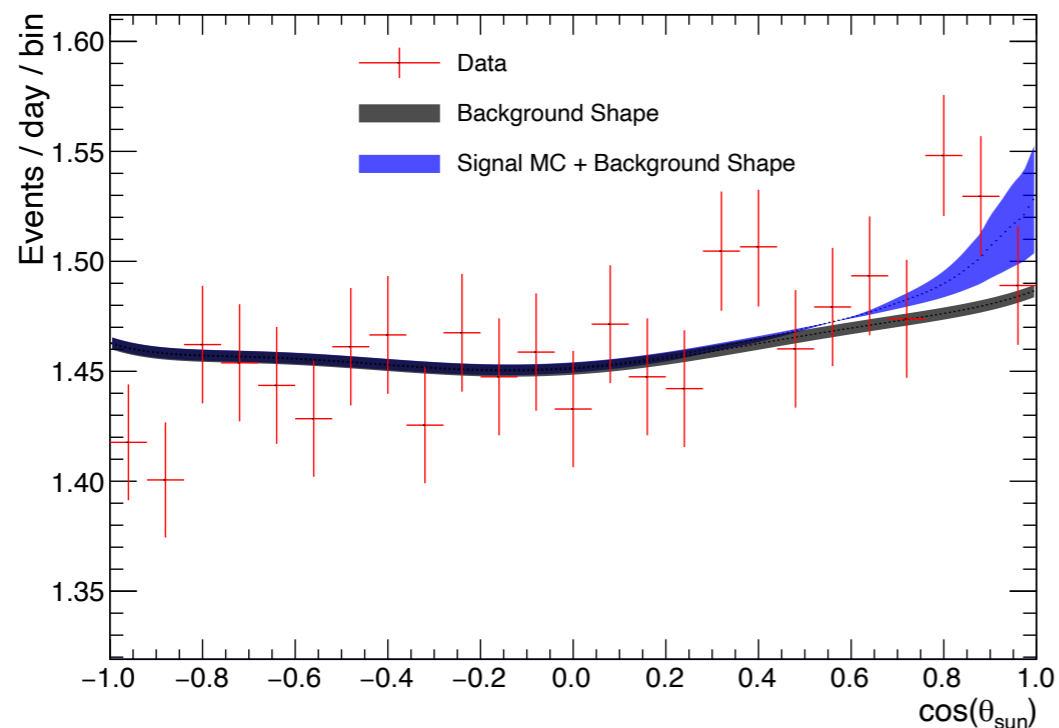

SLE 31-hit 2.99 MeV < E_{kin} < 3.49 MeV

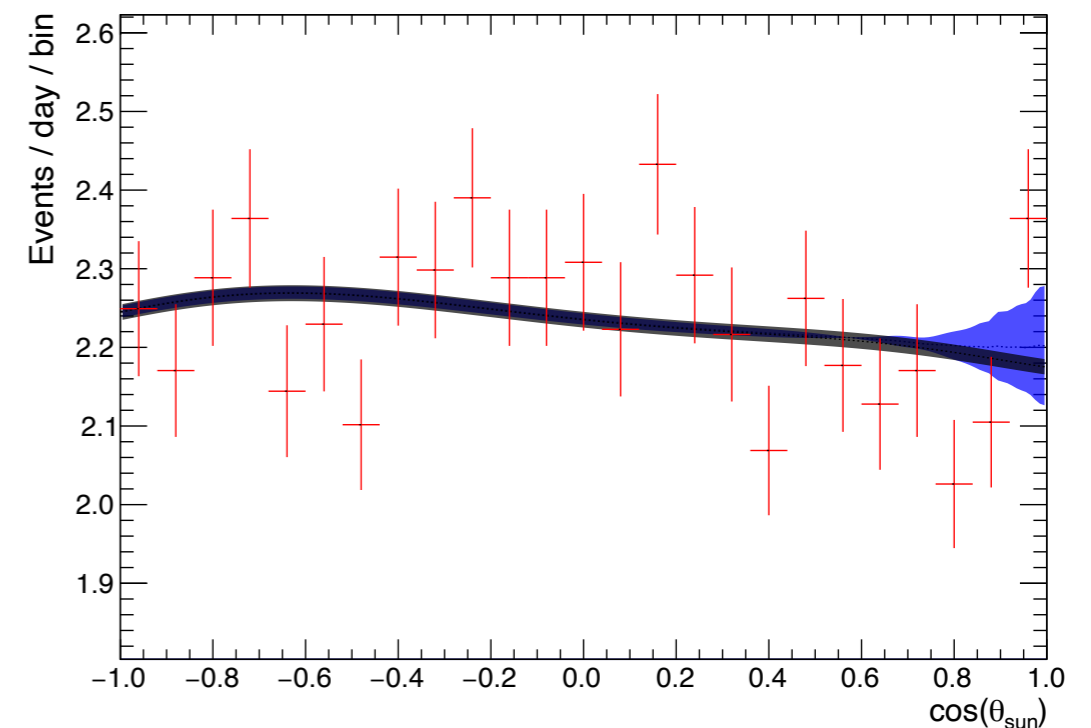

Energy and MSG Bins

WIT

2.49 MeV < E_{kin} < 2.99 MeV

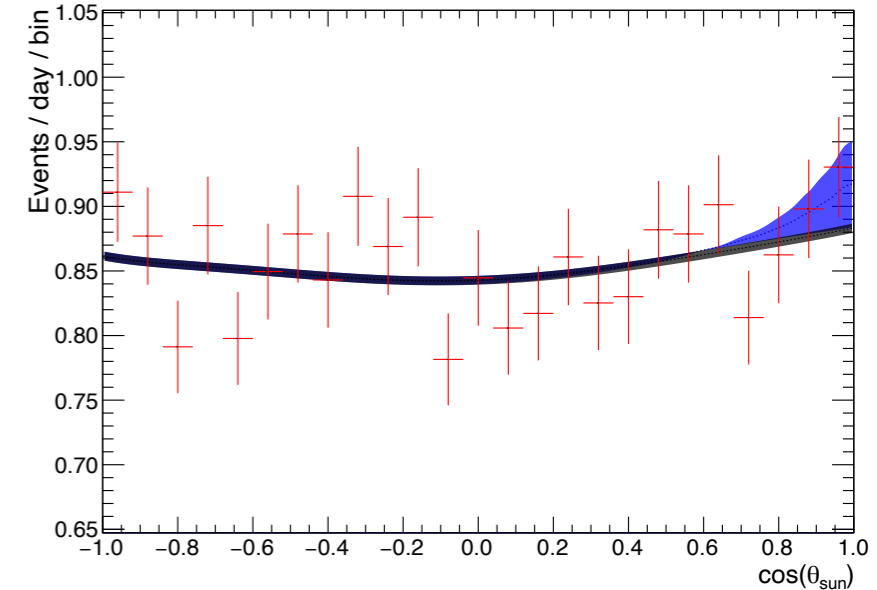
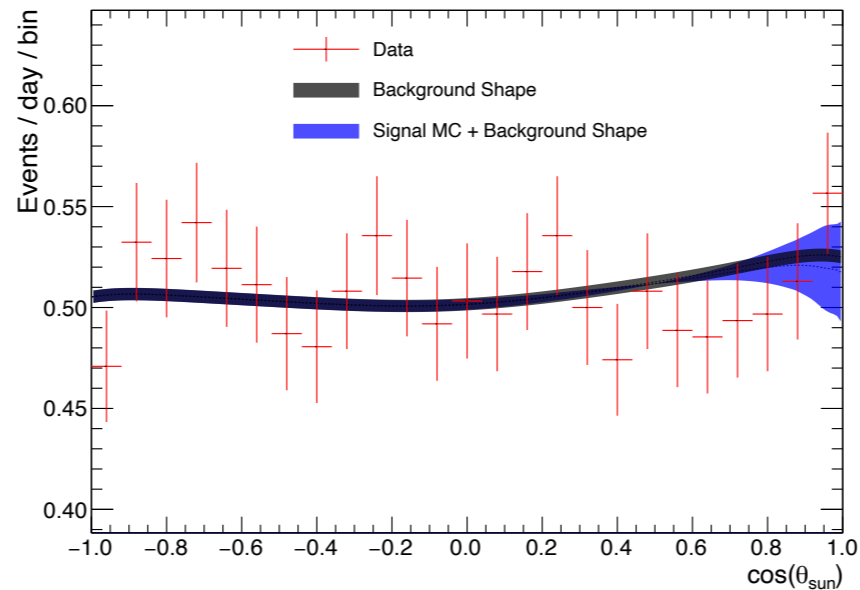
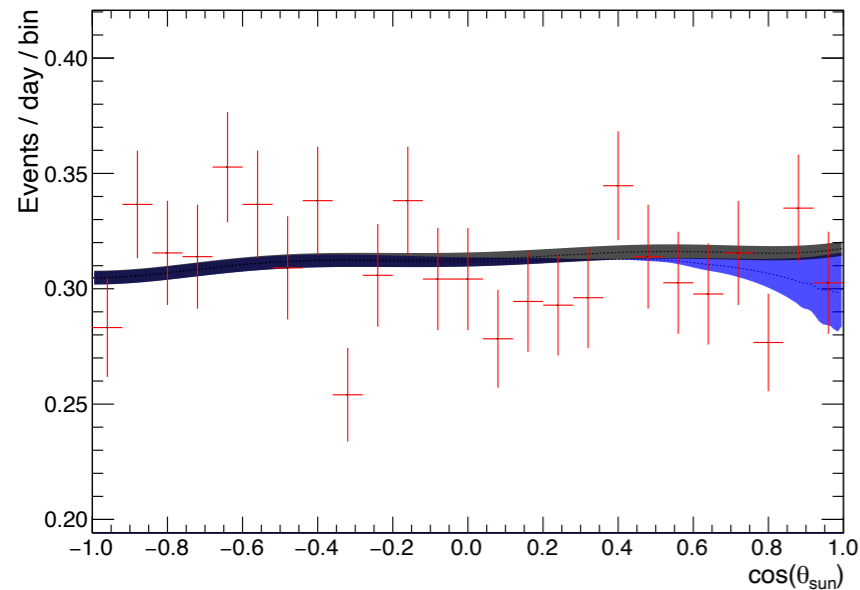

2.99 MeV < E_{kin} < 3.49 MeV

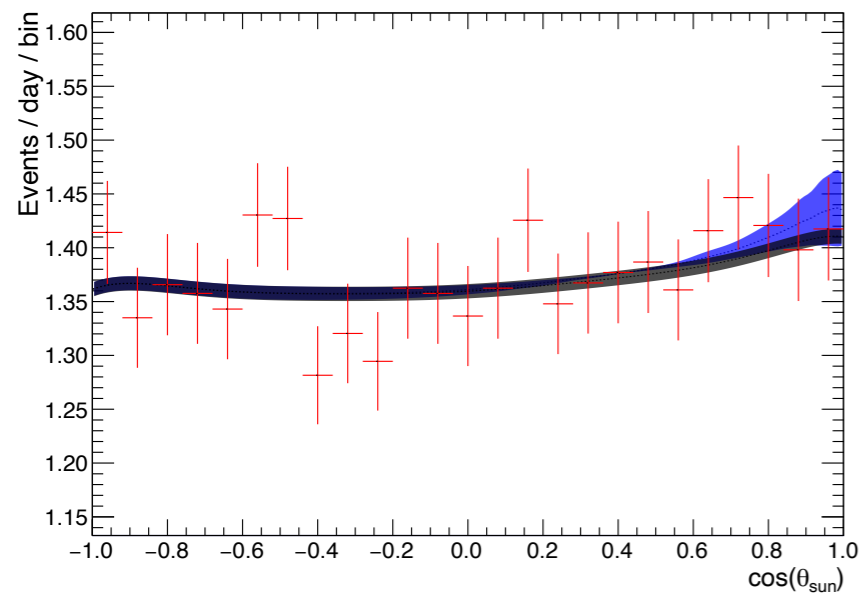

MSG Bin 1

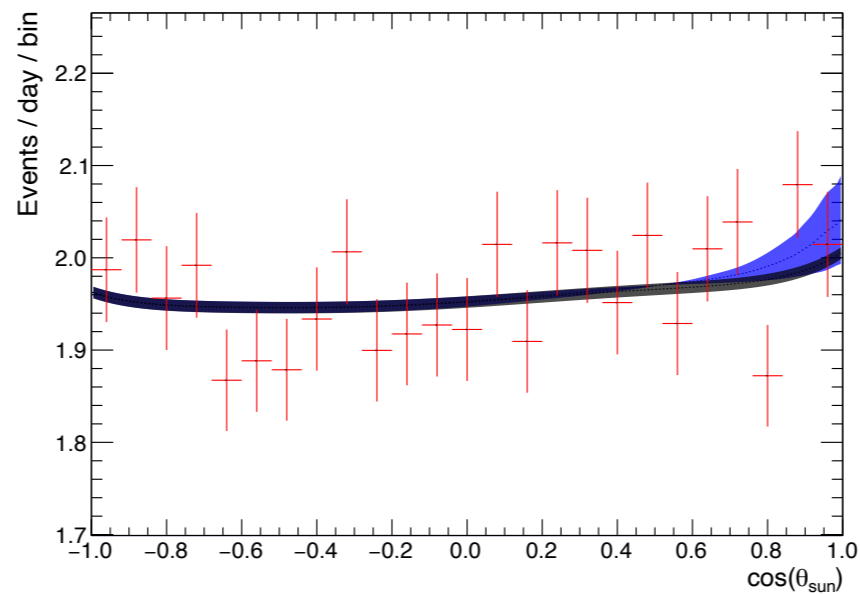

MSG Bin 2

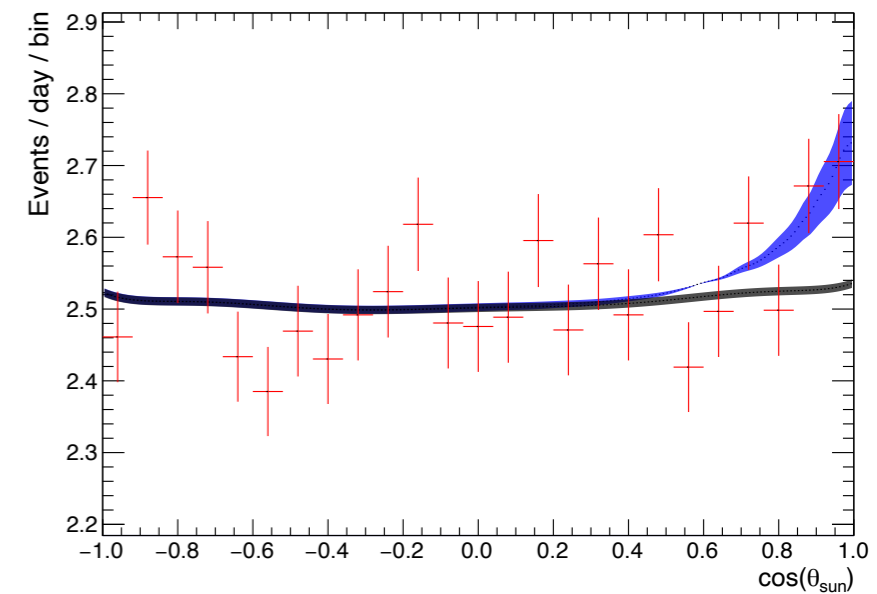

MSG Bin 3

Energy and MSG Bins

SLE

31-Hit Period

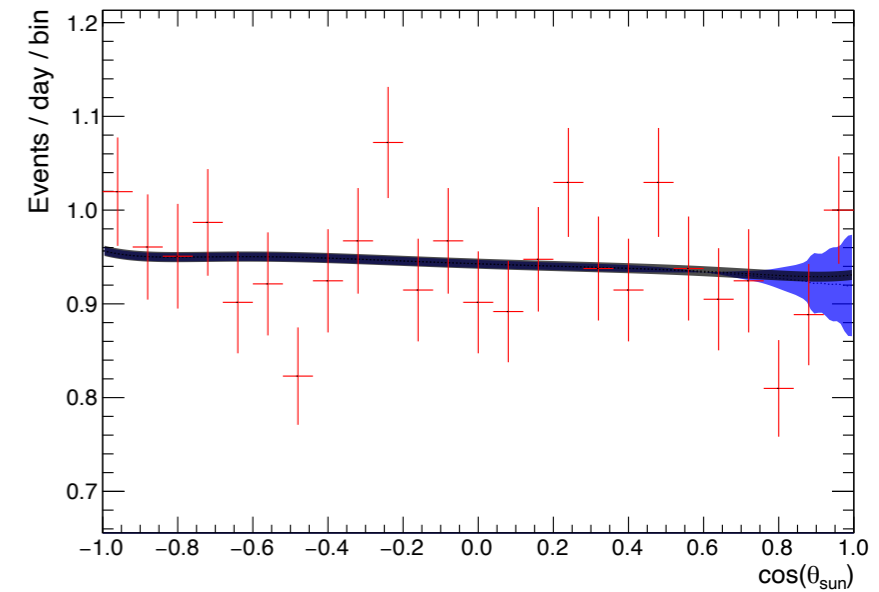
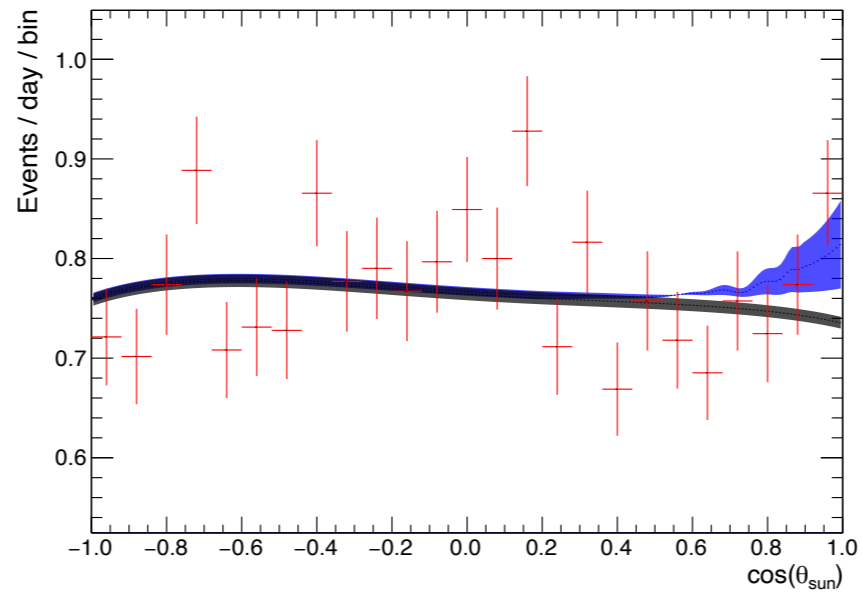
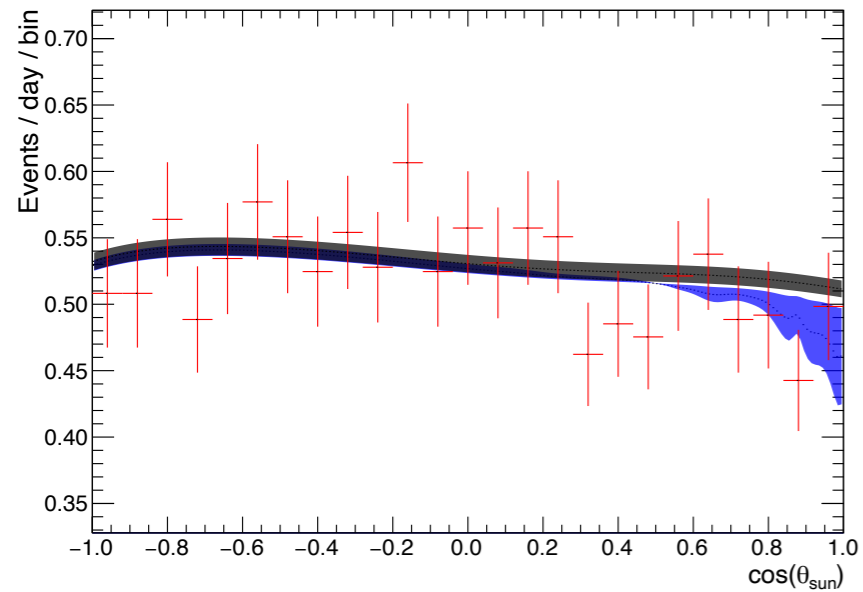

34-Hit Period

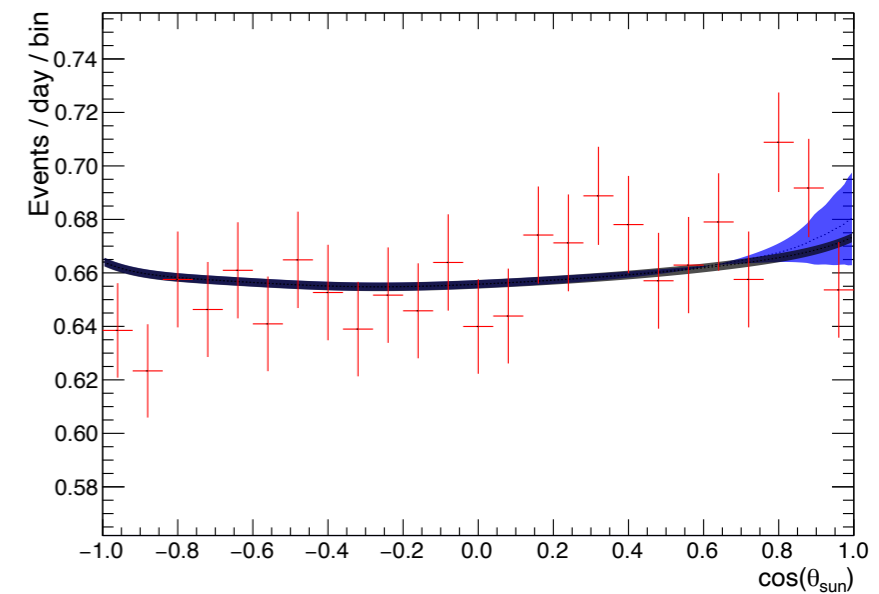
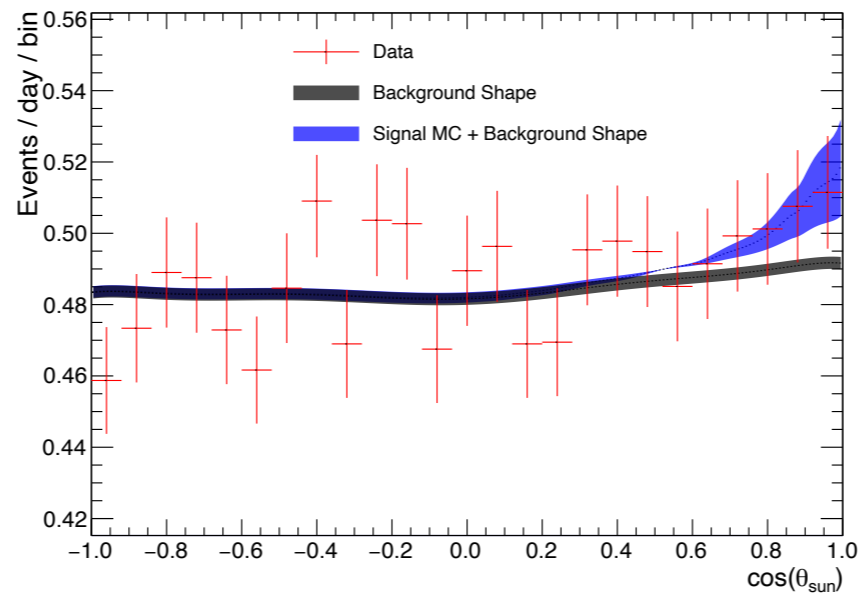
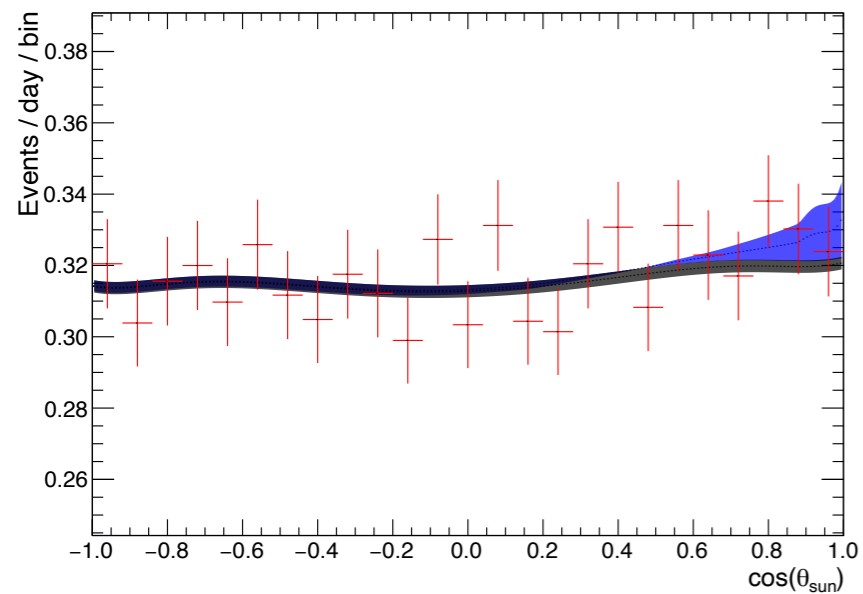

MSG Bin 1

MSG Bin 2

MSG Bin 3

ν_e Survival Probability Spectrum

- Add Exp./Obs. measurement in 2.99 MeV - 3.49 MeV to SK-IV spectra, then conduct exponential and quadratic fits to ν_e survival probability in neutrino energy.
- Minor effects on fits.
 - Slightly narrower confidence region at low energies
 - Shift in best-fit for exponential

Quadratic

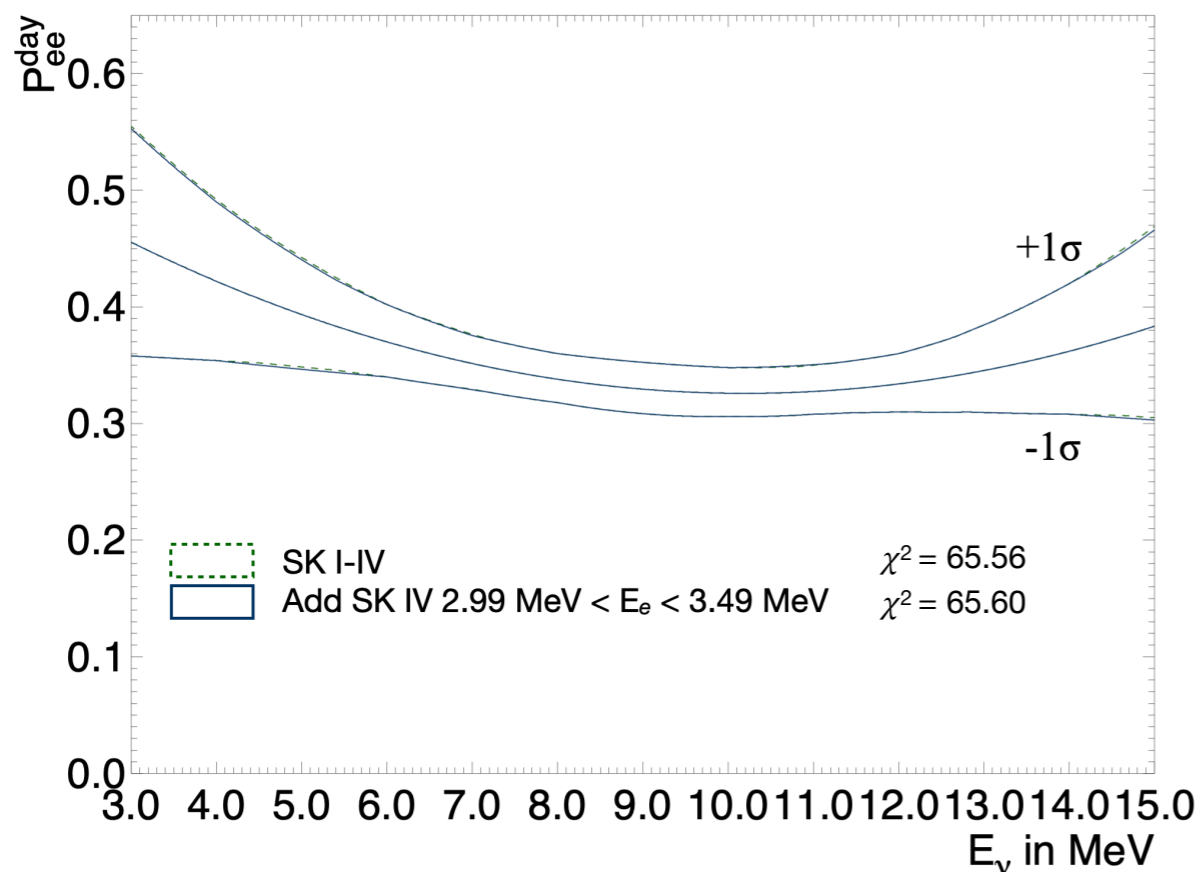

Exponential

