



Joint Workshop of TYL/FJPPN and FKPPN 2026  
18-21 May 2026 @ ACT CITY HAMAMATSU Congress Center, Japan  
18th May, 09:40-

# Experimental and Theoretical Approaches to Soft Matter Phenomena

— *The Physics Hidden in Everyday Life* —

**Marie TANI**

(Division of Physics and Astronomy, Kyoto Univ.)

# Who am I ?

## Marie TANI

..., who is an awardee of  
the 13<sup>th</sup> Toshiko Yuasa Award (silver award)



..., who works on Soft matter & active matter Physics

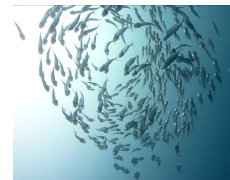

..., who feels that France is like a second home  
Internship, postdoc, ..., sabbatical, ... @ Paris



..., whose first conference abroad was in Korea  
Statphys2013, ..., ICBBS2026  
@ Seoul @ Busan



# FJAMN & KJAMN ?

Kyoto University  
**ACTIVE MATTER LAB**



KYOTO UNIVERSITY



Oct. 2023



Oct. 2024

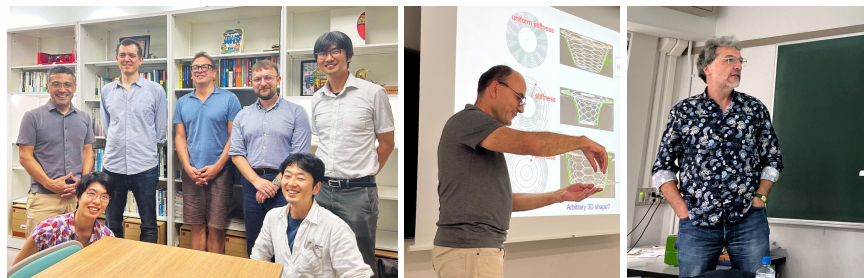

**FJPPN**

France-**J**apan  
Particle **P**hysics **A**ctive-Soft **M**atter  
Laboratory **N**etwork

**FJAMN**

**FKPPN**

France-**K**orea  
Particle **P**hysics **A**ctive-Soft **M**atter  
Laboratory **N**etwork

**KJAMN**

Korea-**J**apan  
Particle **P**hysics **A**ctive-Soft **M**atter  
Laboratory **N**etwork

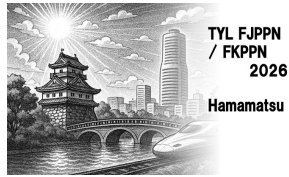

Joint Workshop of TYL/FJPPN and FKPPN 2026  
18-21 May 2026 @ ACT CITY HAMAMATSU Congress Center, Japan  
18th May, 09:40-

# Experimental and Theoretical Approaches to Soft Matter Phenomena

— *The Physics Hidden in Everyday Life* —

**Marie TANI**

(Division of Physics and Astronomy, Kyoto Univ.)

# Soft matter & Active matter

---

– *The Physics Hidden in Everyday Life* –



ubiquitously observed in our everyday life

form, motion & mechanism ?

Understanding through Experiment & simple physical model

# Soft matter & Active matter

---

– *The Physics Hidden in Everyday Life* –

Novel Prize (Physics) in 1991



Dr. Pierre-Gilles  
de Gennes  
(1932-2007)



Claude Monet,  
"Impression, Sunrise"  
(1872)

Complex phenomena can sometimes be understood through surprisingly simple physical principles.

# Soft matter & Active matter

– *The Physics Hidden in Everyday Life* –



Dr. Pierre-Gilles  
de Gennes  
(1932-2007)

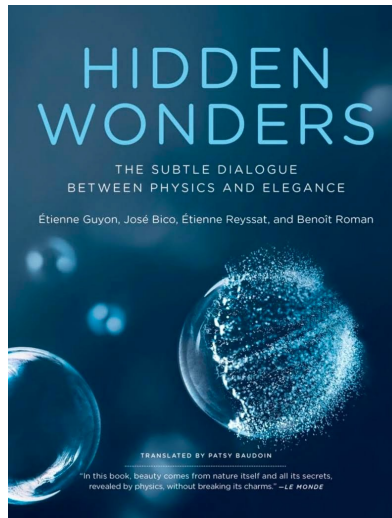

E. Guyon, J. Bico,  
E. Reyssat and B. Roman



[https://www.ae-info.org/ae/Member/Guyon\\_Etienne](https://www.ae-info.org/ae/Member/Guyon_Etienne)

Dr. Etienne Guyon  
(1935-2023)



Giving presentations with some live experiments

# Some of My Works



How does elastic rope coil around a rotating cylinder?

M. Tani and H. Wada,  
*Phys. Rev. Lett.* 132, 058204 (2024).

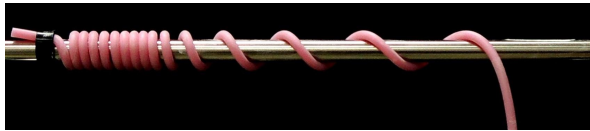

Physics Focus

Transition During Winding of a String

February 2, 2024 - Physics 17:39

As a string winds around a cylinder, a switch occurs from tight winding to looser winding, a behavior that could be relevant for natural phenomena.

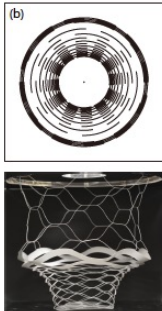
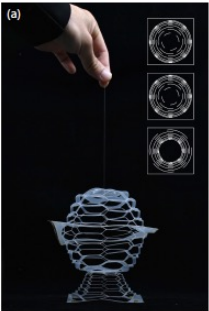
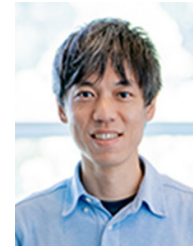

How can we realize a desired 3D shape by kirigami ?

M. Tani, J.-W. Hong, T. Tomizawa, E. Lepoivre, J. Bico and B. Roman,  
*Extr. Mech. Lett.* (2024).



How does liquid pinch off from a foamy droplet?

M. Tani and R. Kurita,  
*Soft Matter* 18, 2137 (2022).

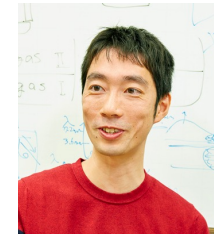

# Coiling, wrapping, twining, ...

... observed with various materials/ on various scales

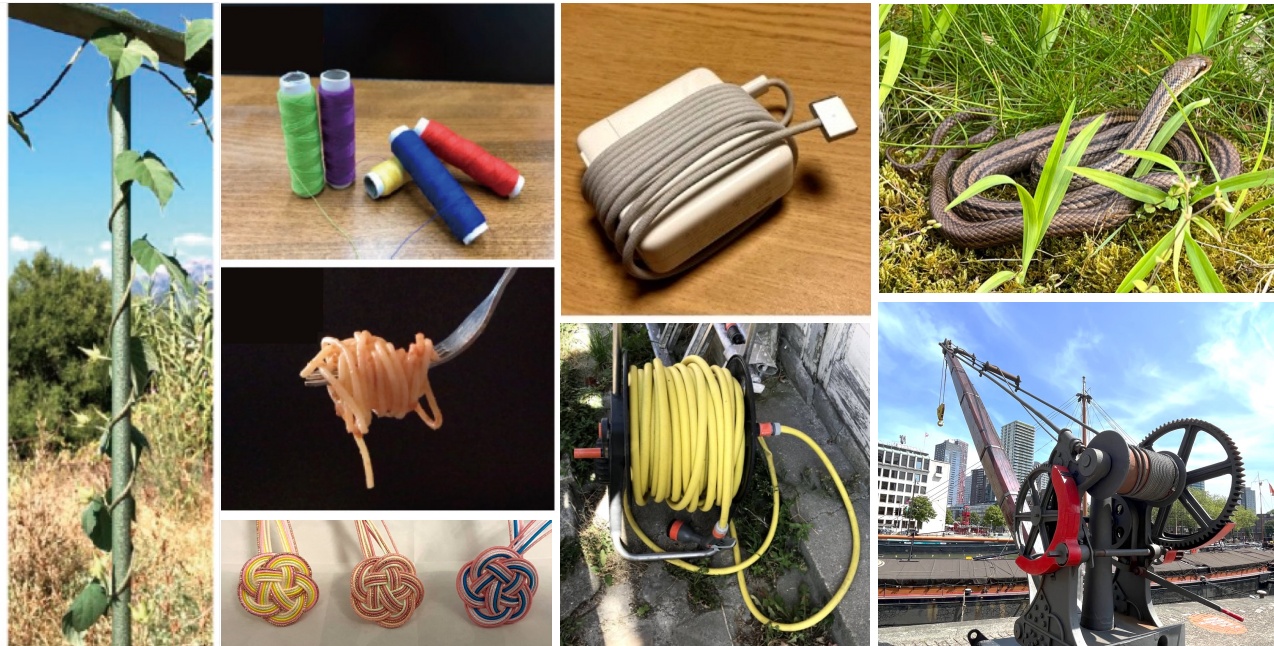

## Questions:

- coiling or not?
- coiling patterns?

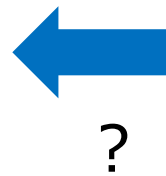

## Physical factors:

- elasticity
- body force (gravity etc.)
- geometry
- friction

Polyvinyl siloxane

# Model Experiment

---



**Zhermack**  
Dental



Polyvinyl siloxane

# Model Experiment



**Zhermack**  
Dental

**Tight** coiling

**Helical** twining

**No** wrapping

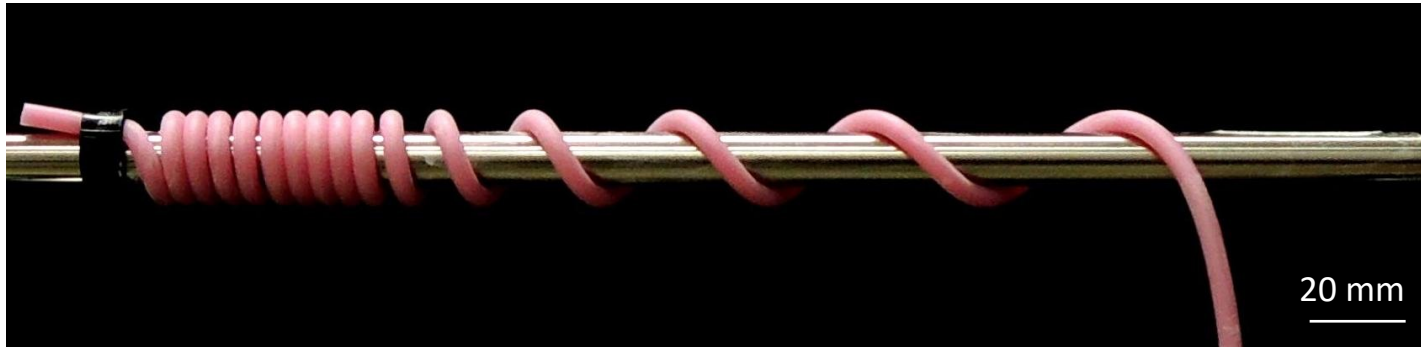

# Various Morphologies

Ex.)

$$a = 2.0 \text{ mm,}$$

$$R_0 = 4.8 \text{ mm,}$$

$$L_{gb} = 28.2 \text{ mm,}$$

$$L = 781.0 \text{ mm}$$

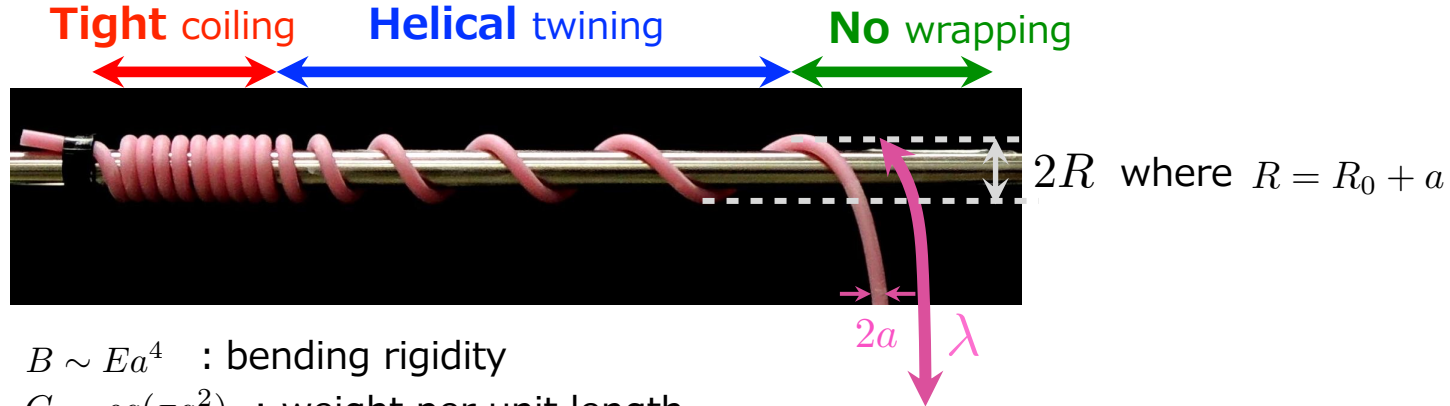

$$L_{gb} = \left( \frac{B}{G} \right)^{1/3}$$

$B \sim Ea^4$  : bending rigidity

$G = \rho g(\pi a^2)$  : weight per unit length

Gravito-bending length

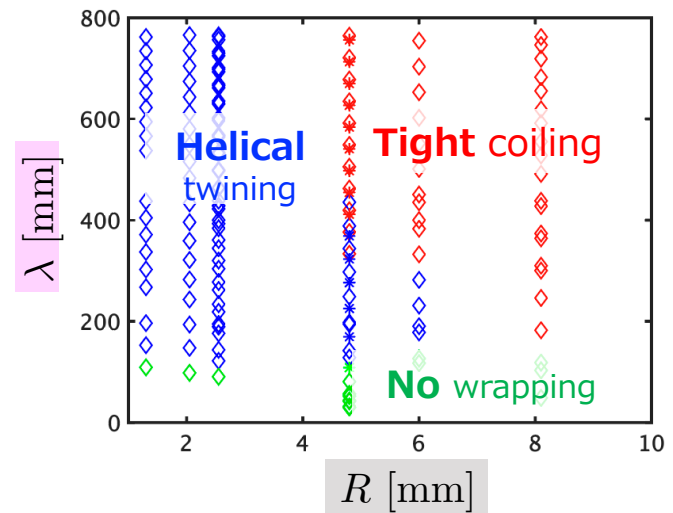
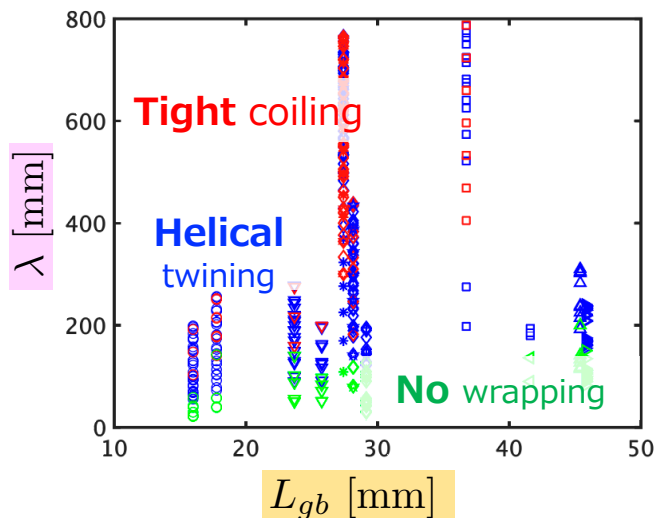

# Morphology Phase Diagram

Ex.)

$$a = 2.0 \text{ mm,}$$

$$R_0 = 4.8 \text{ mm,}$$

$$L_{gb} = 28.2 \text{ mm,}$$

$$L = 781.0 \text{ mm}$$

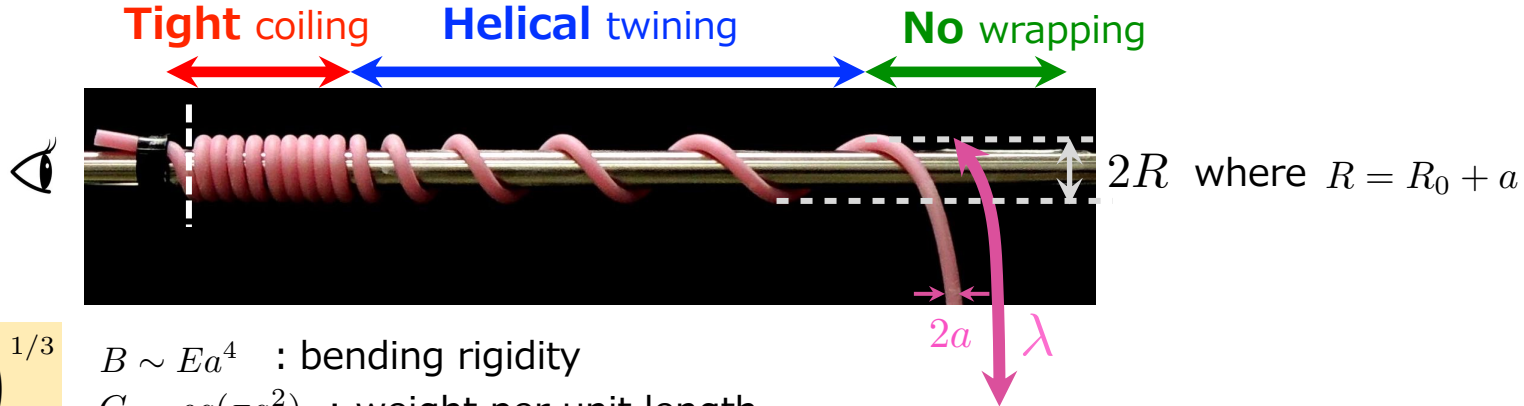

$$L_{gb} = \left( \frac{B}{G} \right)^{1/3}$$

$B \sim Ea^4$  : bending rigidity

$G = \rho g(\pi a^2)$  : weight per unit length

Gravito-bending length

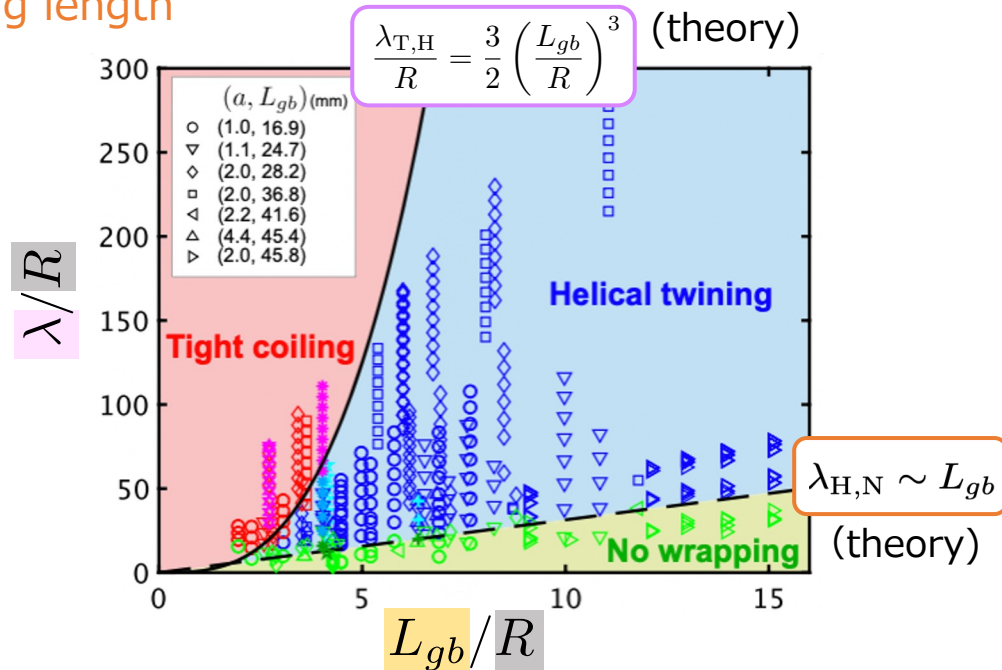

# Basic physics of coiling (2D)

An elastic rod  
bending modulus:  $B$

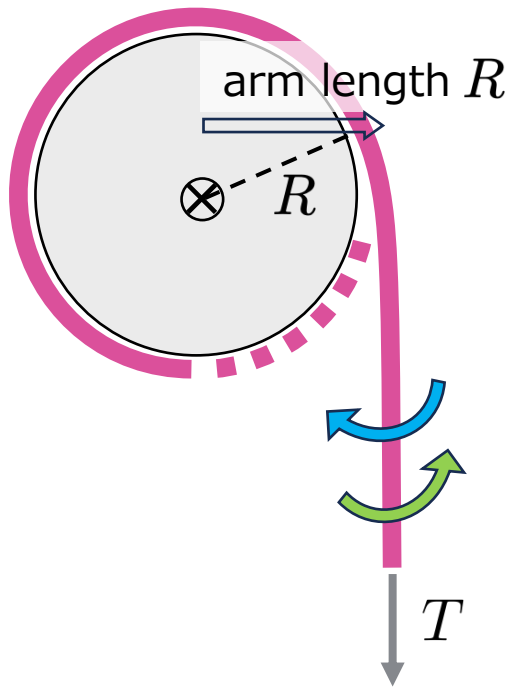

$$M_{ext.} \sim TR$$

$$M_B \sim \frac{B}{R}$$

Coiling if:

$$M_{ext.} > M_B$$

$$\rightarrow T > T_c \sim \frac{B}{R^2}$$

# Basic physics of coiling (2D)

by gravity

An elastic rod  
bending modulus:  $B$

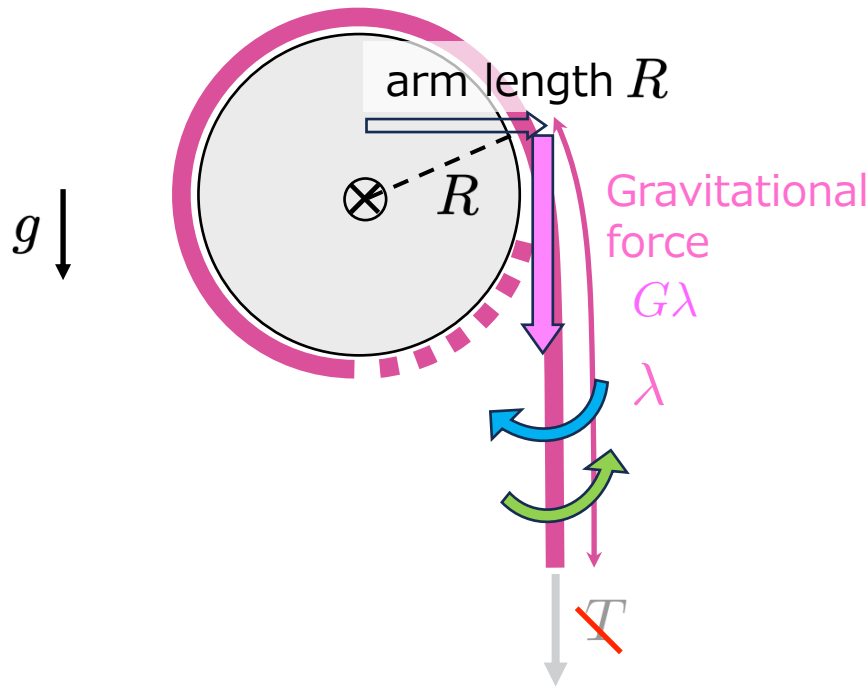

$$M_g \sim G\lambda R$$

~~$$M_{ext.} \sim TR$$~~

$$M_B \sim \frac{B}{R}$$

Tight Coiling if:

~~$$M_{ext.} > M_B$$~~

$$M_g > M_B$$

$$\rightarrow \cancel{T} > T_c \sim \frac{B}{R^2}$$

$$G\lambda$$

$$\lambda > \lambda_{T,H} \sim \frac{B}{GR^2} = \frac{L_{gb}^3}{R^2}$$

$$L_{gb} = \left(\frac{B}{G}\right)^{1/3}$$

$B \sim Ea^4$  : bending rigidity

$G = \rho g(\pi a^2)$  : weight per unit length

Gravito-bending length

Benson, *Transactions of the ASME* (1998)

$$\frac{\lambda_{T,H}}{R} \sim \left(\frac{L_{gb}}{R}\right)^3$$

# Morphology Phase Diagram

Ex.)

$$a = 2.0 \text{ mm,}$$

$$R_0 = 4.8 \text{ mm,}$$

$$L_{gb} = 28.2 \text{ mm,}$$

$$L = 781.0 \text{ mm}$$

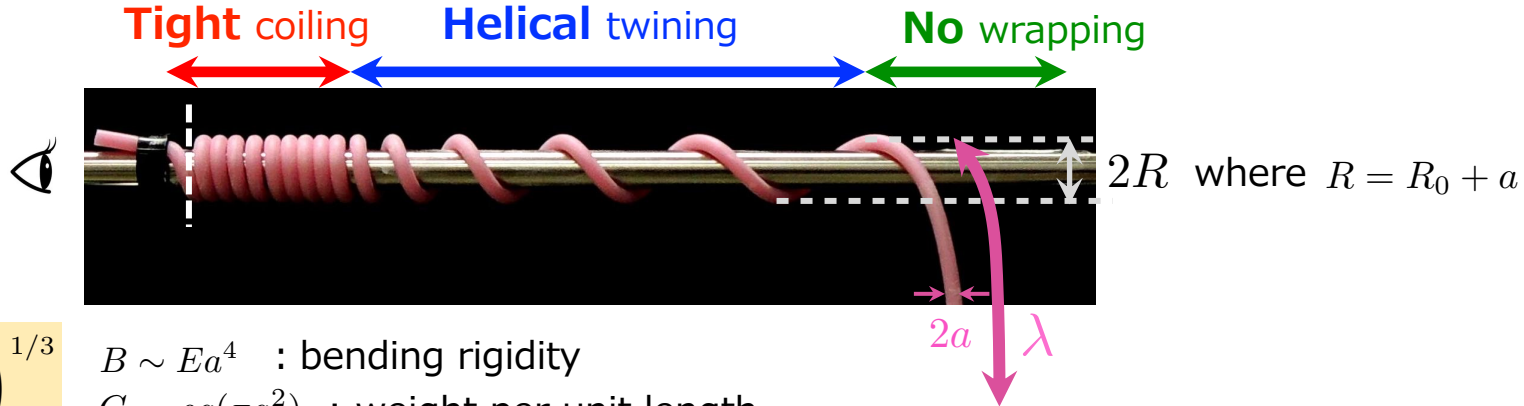

$$L_{gb} = \left( \frac{B}{G} \right)^{1/3}$$

$B \sim Ea^4$  : bending rigidity

$G = \rho g(\pi a^2)$  : weight per unit length

Gravito-bending length

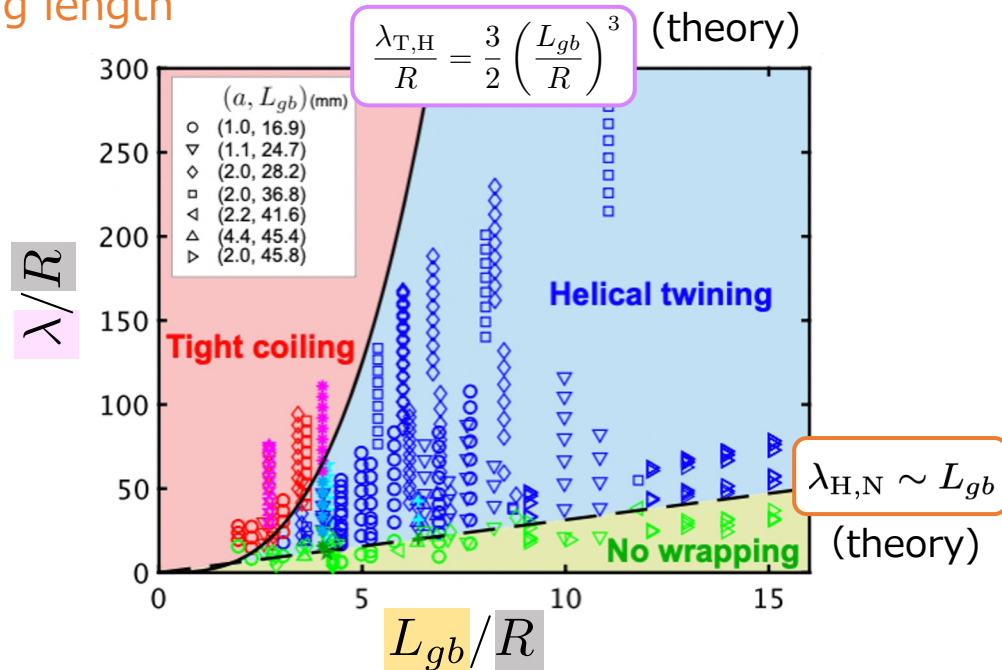

# Short Conclusion

QUESTIONS: coiling or not? coiling patterns?

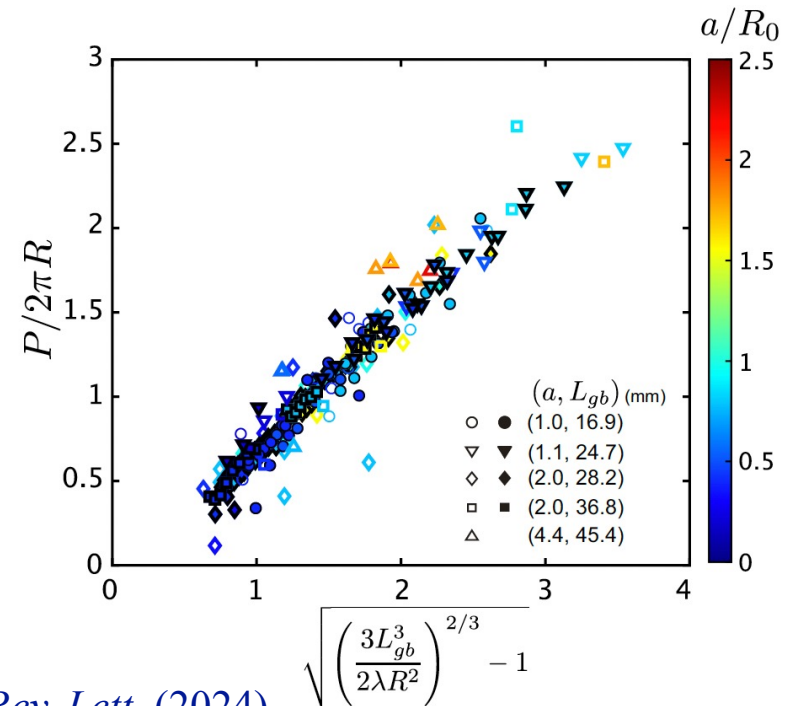
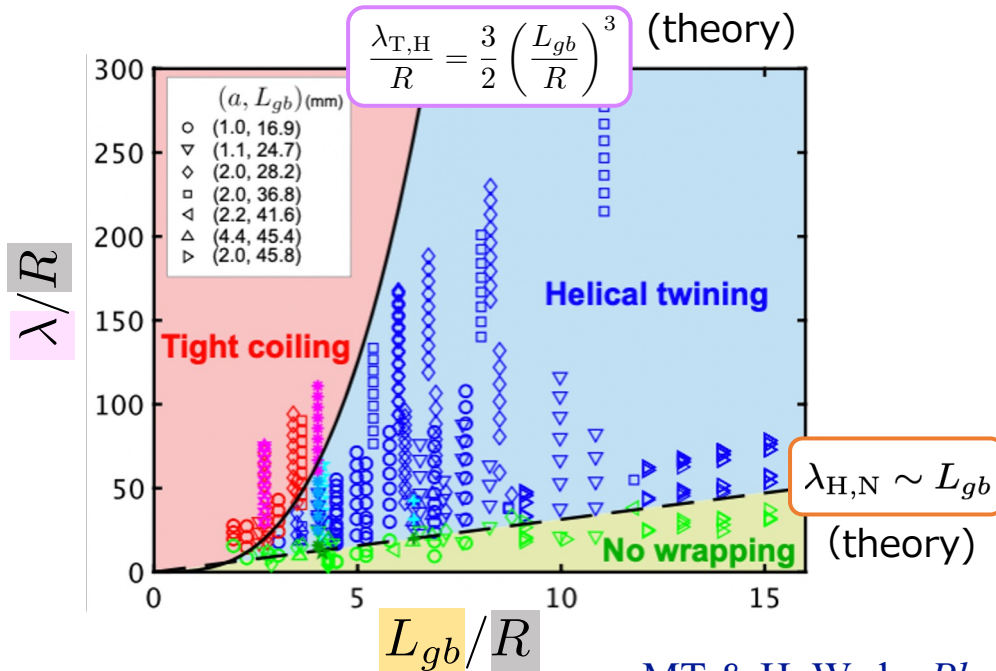
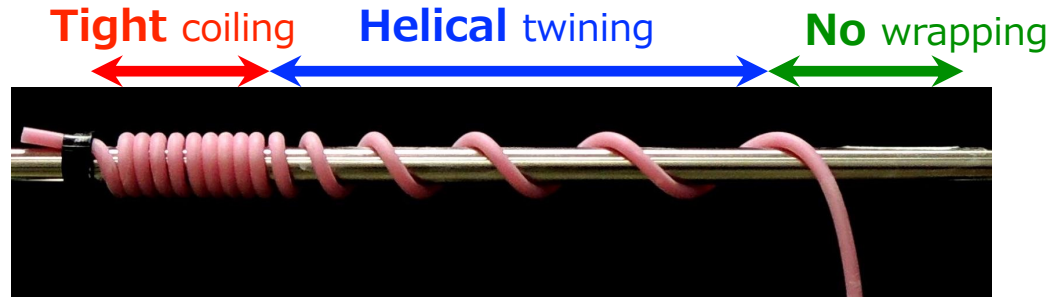

# Some of My Works



How does elastic rope coil around a rotating cylinder?

M. Tani and H. Wada,  
*Phys. Rev. Lett.* 132, 058204 (2024).

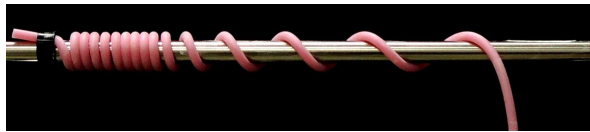

Physics Focus

Transition During Winding of a String

February 2, 2024 • Physics 11.18  
As a string winds around a cylinder, a switch occurs from tight winding to looser winding, a behavior that could be relevant for natural phenomena.

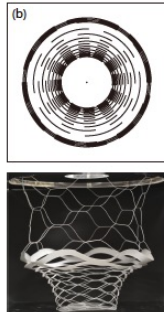
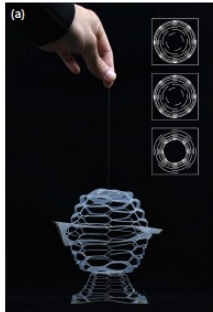

How can we realize a desired 3D shape by kirigami ?

M. Tani, J.-W. Hong, T. Tomizawa, E. Lepoivre, J. Bico and B. Roman,  
*Extr. Mech. Lett.* (2024).



How does liquid pinch off from a foamy droplet?

M. Tani and R. Kurita,  
*Soft Matter* 18, 2137 (2022).

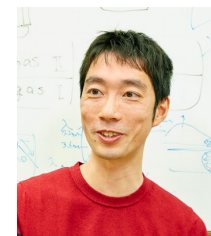

# Origami & Kirigami

“ori-” +  
fold

“kiri-” +  
cut

“kami”  
paper

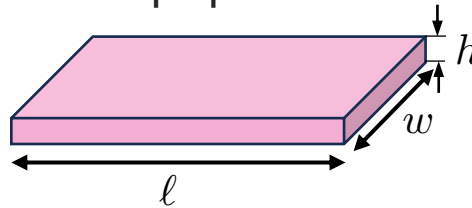

→ rigidity ↗

→ flexibility ↗

- High stretchability

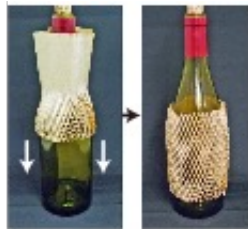

Isobe, *Sci. Rep.* 2016

- 2D → 3D



K.F Gauss  
(1777-1855)

Gauss Theorema egregium

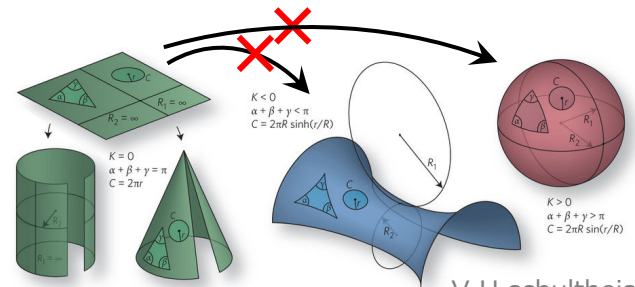

V.H schultheiss

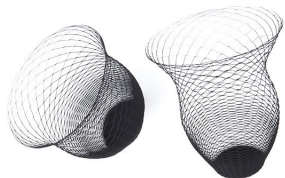

Air vase:  
Design Torafu Architects



VinStrip Mini:  
Cavaliere Interni



Wikipedia

# Kirigami → 3D structure

a desired 3D shape

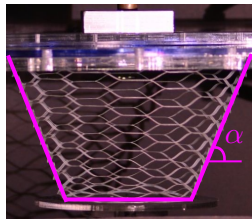

“cone” shape

making a 3D shape (experiment)

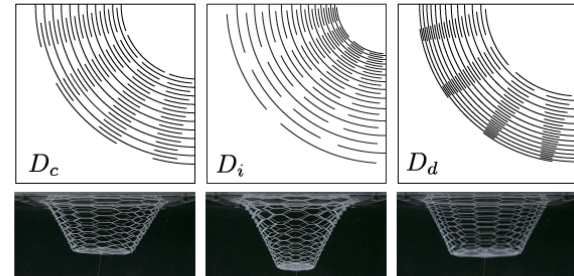

programming a cutting pattern

(theory)

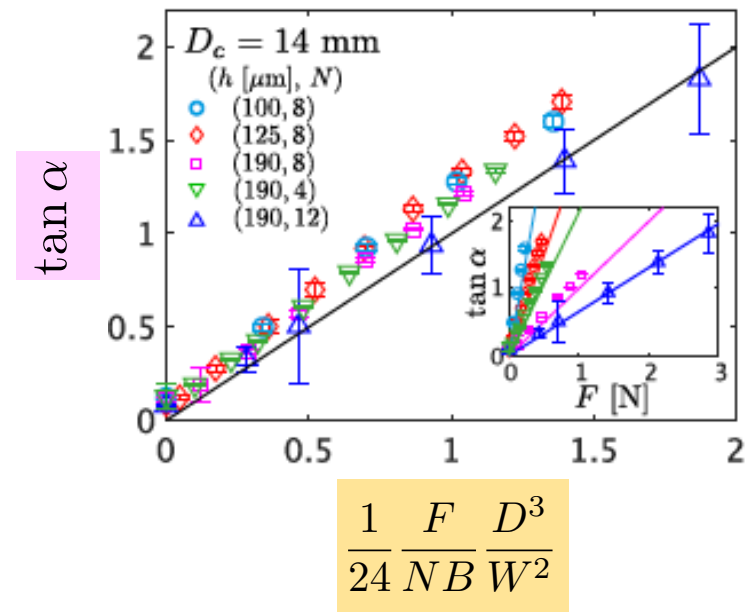
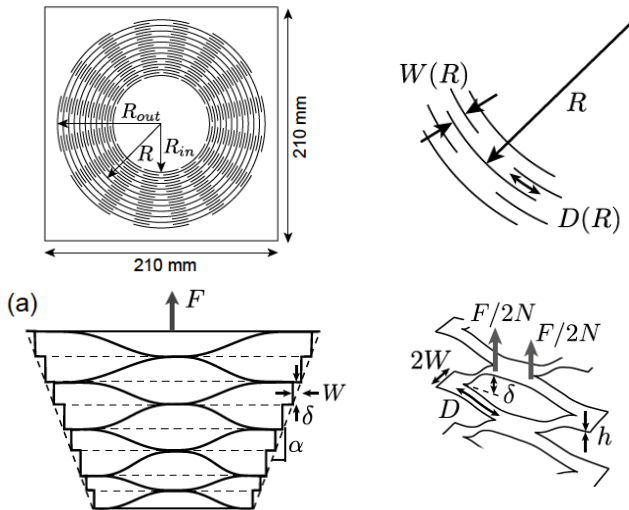

$$\tan \alpha = \frac{dz}{dr} = \frac{\delta}{W} = \frac{1}{24} \frac{F}{NB} \frac{D^3}{W^2}$$

cone shape if:  $\frac{D(R)^3}{W(R)^2} = \text{const.}$

# Kirigami → 3D structure

a desired 3D shape

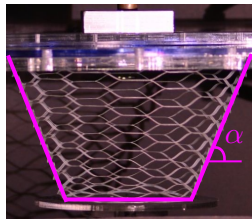

“cone” shape

programming a cutting pattern (theory)

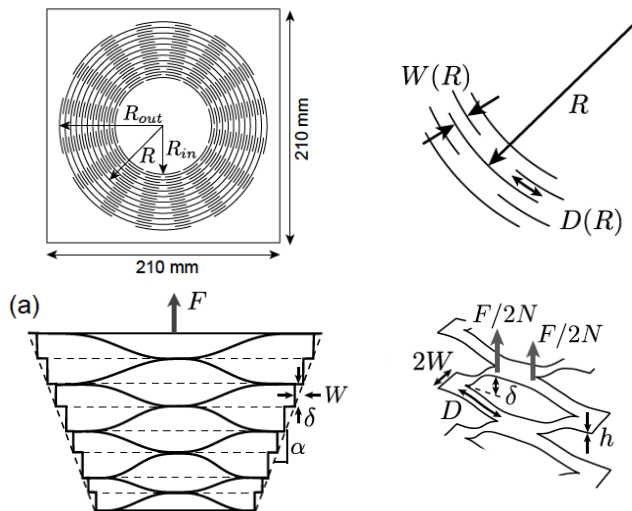

$$\tan \alpha = \frac{dz}{dr} = \frac{\delta}{W} = \frac{1}{24} \frac{F}{NB} \frac{D^3}{W^2}$$

cone shape if:  $\frac{D(R)^3}{W(R)^2} = \text{const.}$

By varying the function of  $\frac{D(R)^3}{W(R)^2}$ ,

(a) bowl shape

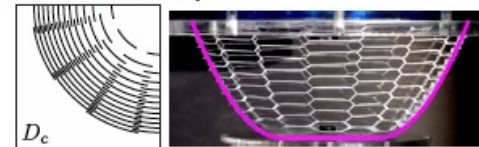

(b) trumpet shape

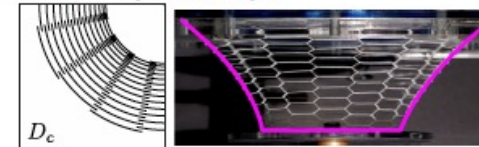

(c) hemisphere shape

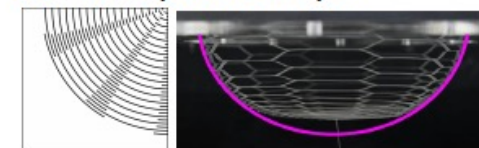

(d) suction cup shape

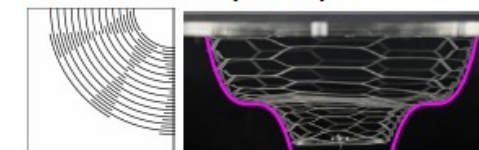

Inverse engineering

# Kirigami → 3D structure

a desired 3D shape

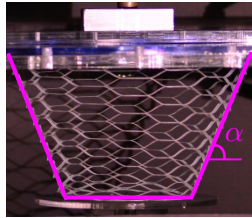

“cone” shape

By varying the function of  $\frac{D(R)^3}{W(R)^2}$ ,

programming a cutting pattern  
(theory)

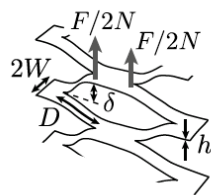
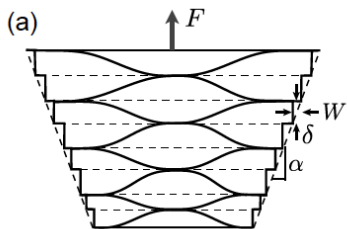
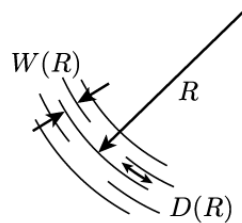
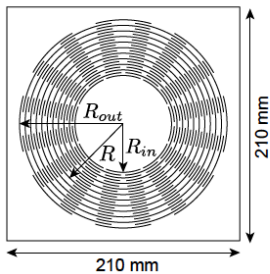

$$\tan \alpha = \frac{dz}{dr} = \frac{\delta}{W} = \frac{1}{24} \frac{F}{NB} \frac{D^3}{W^2}$$

cone shape if:  $\frac{D(R)^3}{W(R)^2} = \text{const.}$

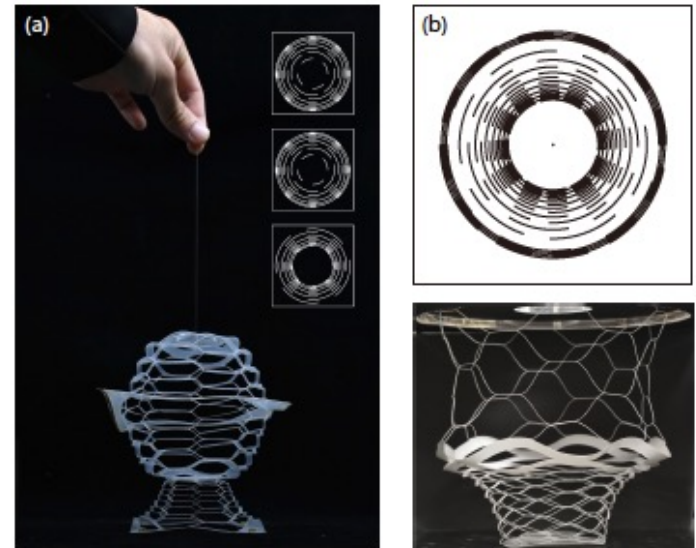

Inverse engineering

# Some of My Works



How does elastic rope coil around a rotating cylinder?

M. Tani and H. Wada,  
*Phys. Rev. Lett.* 132, 058204 (2024).

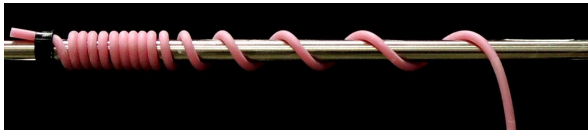

Physics Focus

Transition During Winding of a String

February 2, 2024 • Physics 11.18  
As a string winds around a cylinder, a switch occurs from tight winding to looser winding, a behavior that could be relevant for natural phenomena.

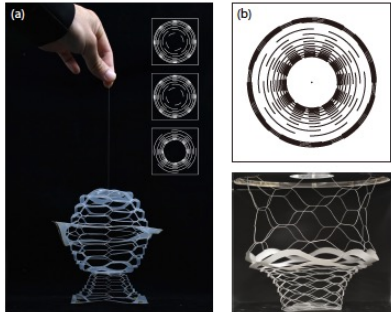
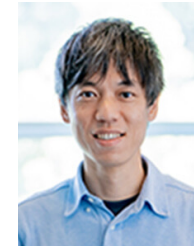

How can we realize a desired 3D shape by kirigami ?

M. Tani, J.-W. Hong, T. Tomizawa, E. Lepoivre, J. Bico and B. Roman,  
*Extr. Mech. Lett.* (2024).

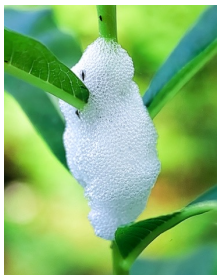

How does liquid pinch off from a foamy droplet?

M. Tani and R. Kurita,  
*Soft Matter* 18, 2137 (2022).

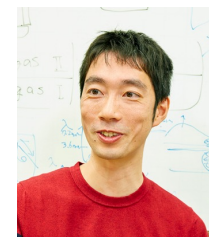

# Liquid Foam

---

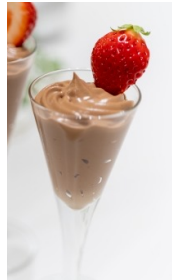

foods/drinks



shaving foam



cleaning/washing foam



animals



When does a foamy droplet fall down?

When does liquid pinch off from a foamy droplet?

# Liquid Pinch-off from a Foam

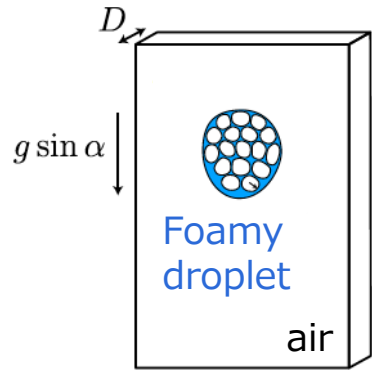

No pinch-off



Pinch-off



Theory Liquid pinches off if :

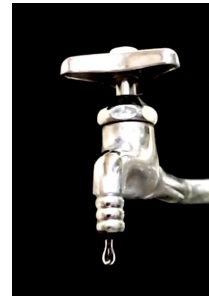

weight

$$m_\ell g \sin \theta >$$

capillary force

$$2D\gamma$$

$$m_\ell > \frac{2D\gamma}{g \sin \alpha}$$

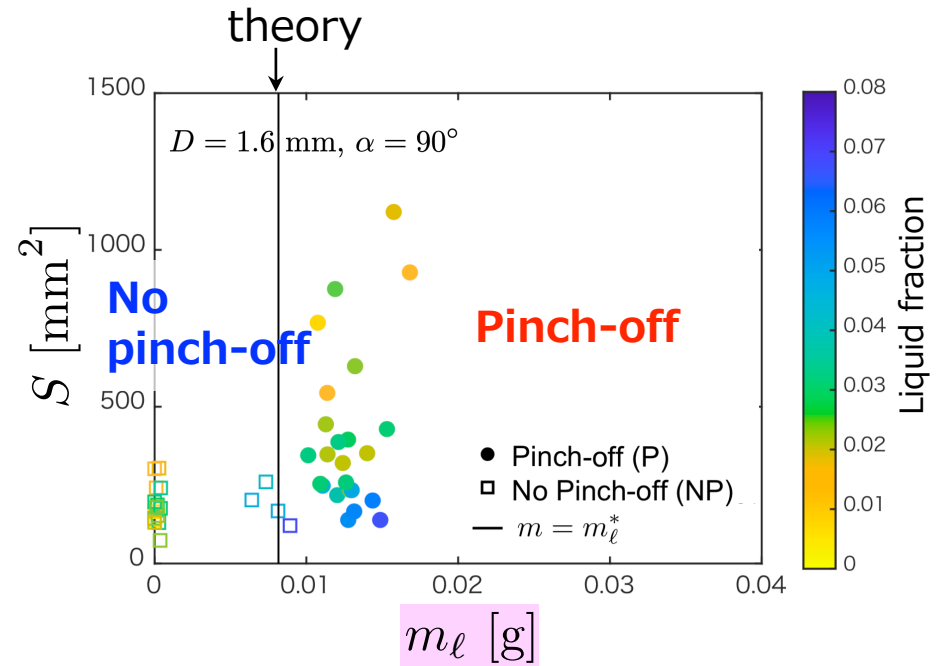

To prevent pinch-off, liquid volume  $\downarrow$  or drainage rate  $\downarrow$ .

# Some of My Works



How does elastic rope coil around a rotating cylinder?

M. Tani and H. Wada,  
*Phys. Rev. Lett.* 132, 058204 (2024).

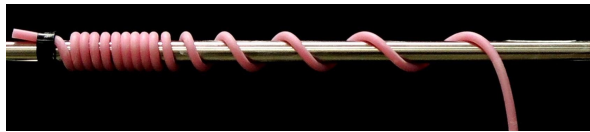

Physics Focus

Transition During Winding of a String

February 2, 2024 • Physics 11.18  
As a string winds around a cylinder, a switch occurs from tight winding to looser winding, a behavior that could be relevant for natural phenomena.

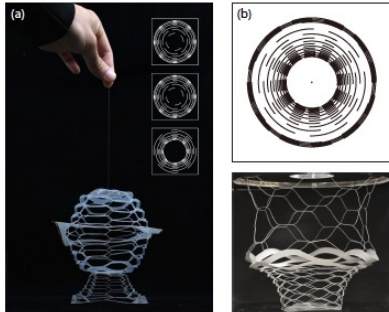

How can we realize a desired 3D shape by kirigami ?

M. Tani, J.-W. Hong, T. Tomizawa, E. Lepoivre, J. Bico and B. Roman,  
*Extr. Mech. Lett.* (2024).



How does liquid pinch off from a foamy droplet?

M. Tani and R. Kurita,  
*Soft Matter* 18, 2137 (2022).

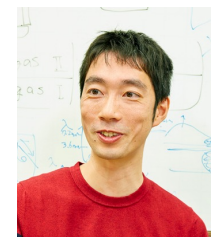

# Soft matter & Active matter

---

– *The Physics Hidden in Everyday Life* –



ubiquitously observed in our everyday life

form, motion & mechanism ?

Understanding through Experiment & simple physical model

# Swarm in nature

---

Fish schools

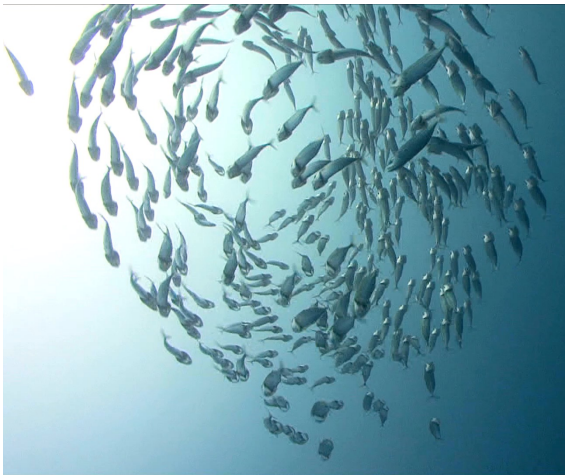

Ant colonies



Cells

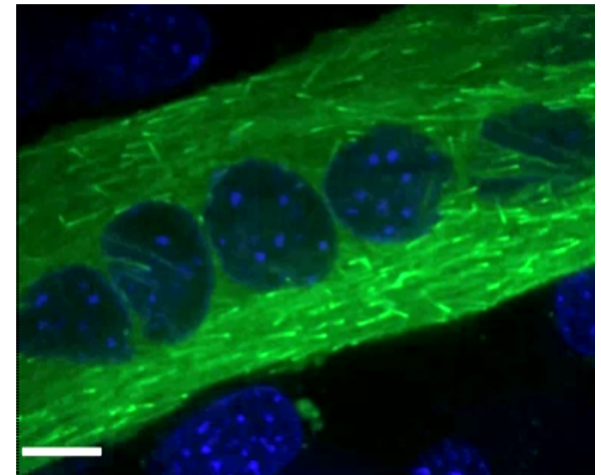

universal phenomenon observed across a wide range of scales

Some advantages?

Parallelism

Flexibility

Robustness

# Are Swarms More Efficient ?

Can larger swarms generate larger forces?

*a stupid question?*

Ex. Tug of war



To generate larger forces,  
we coordinate our actions

(ex. when & how to pull in tug-of-war)

## Ringelmann effect

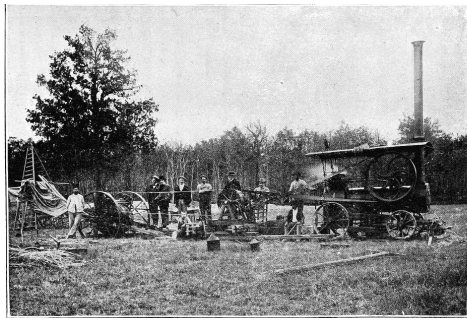

Fig. 2. — Essais dynamométriques d'un treuil de labourage.

“Groups fail to reach  
their full potential”

Reasons:

- loss of motivation
- **coordination problems**

M. Ringelmann, *Annales de l'Institut National Agronomique* (1913)

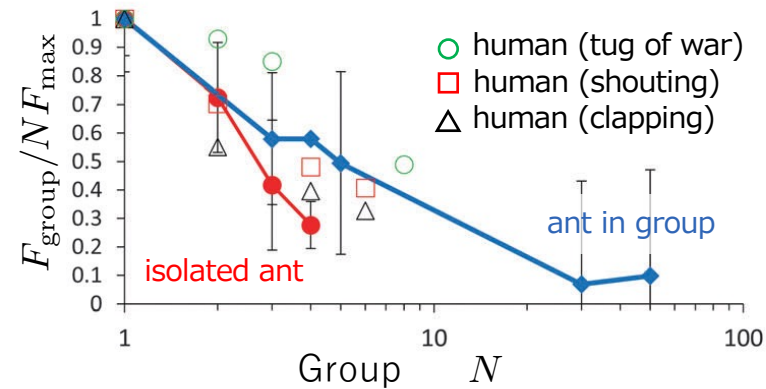

S. Phoenix, *Softmatter* (2016)

Does Ringelmann effect happen even in a swarm of materials ?

# Swarm force

## Questions:

- 1) How does force scale with the number of agent ?
- 2) Ringelmann effect also apply to molecular swarm ?

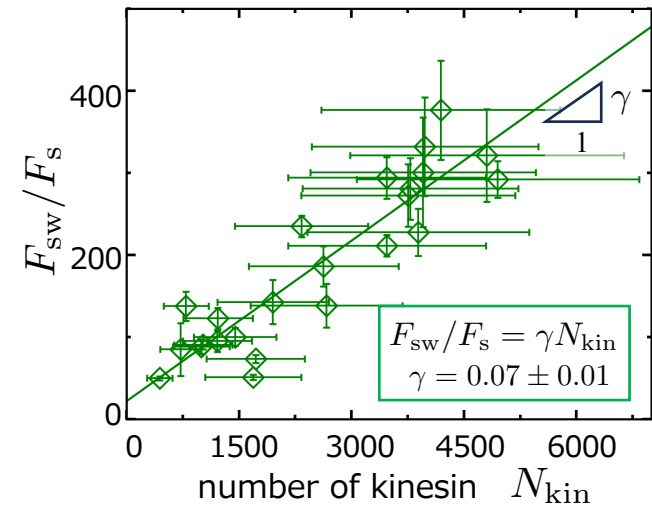
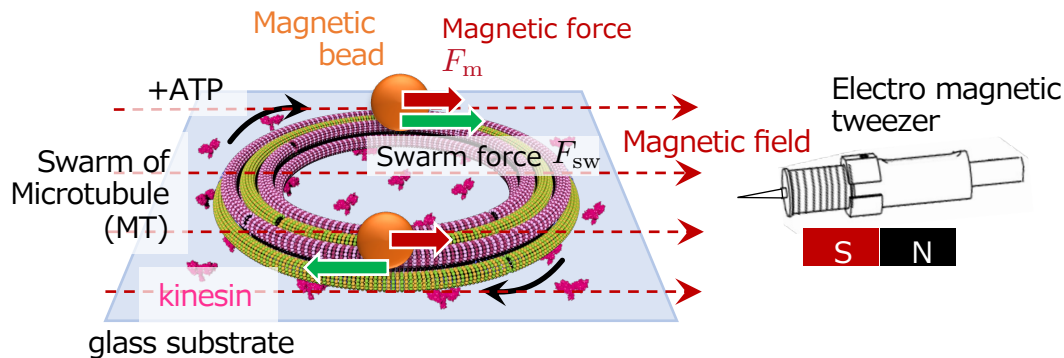

- 1) The swarm force increases linearly with the number of kinesin.
- 2) Yes and No. The productivity per individuals lower but constant.

# Acknowledgement



Ko Okumura  
(Ochanomizu Univ.)



José Bico,  
Etienne Reyssat,  
Benoît Roman  
(PMMH-ESPCI)



Hirofumi Wada  
(Ritsumeikan Univ.)

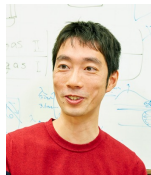

Rei Kurita  
(Tokyo Metropolitan Univ.)



Akira Kakugo  
Ibuki Kawamata  
(Kyoto Univ.)



## Fund



お茶の水女子大学  
Ochanomizu University



JAPAN SOCIETY FOR THE PROMOTION OF SCIENCE  
日本学術振興会



TOKYO  
METROPOLITAN  
UNIVERSITY



Japan Science and Technology Agency



*Fusion Oriented REsearch for  
disruptive Science and Technology*

Toshiko Yuasa Laboratory

*Thank you for your attention!*