

FJPPN D_RD_33
AC-LGAD Detector with
Continuous Readout for
4-Dimensional High-Resolution Measurement at
EIC ePIC



Christophe de La Taille (Ecole Polytechnique)

Kenta Shigaki (Hiroshima University)

TYL/FJPPN and FKPPN Joint Workshop

19 May 2026, Hamamatsu, Japan

Presentation Outline



- ePIC experiment at electron ion collider
- barrel time of flight detector with strip AC-LGAD
 - R&D status and plans
 - perfect combination of Japan - France (- US)
- 2025 highlights (no funding used; thanks anyway)
- 2026 plans (thanks in advance)
- collaborators
 - France/Japan institutes, members, roles
 - PhD students (and PD)
- summary and concluding remarks



Electron Ion Collider at a Glance

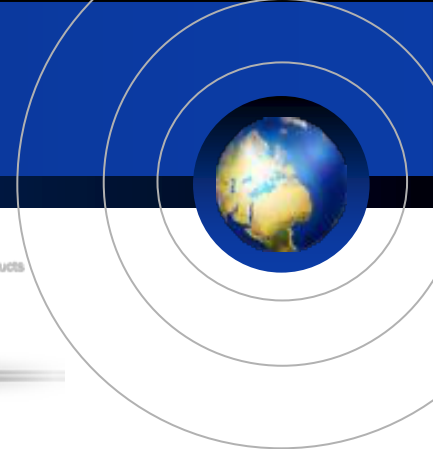

- at Brookhaven National Lab., NY
 - jointly with JLab, VA
- center of mass energy at 29–140 GeV (e-p)
 - 80% pol. electrons at 5–18 GeV
 - 70% pol. protons at 40–275 GeV
 - pol. light ions (d, ^3He) at 40–184 GeV
 - heavier ions at 40–110 A GeV
- luminosity at 10^{33} – 10^{34} $\text{cm}^{-2}\text{s}^{-1}$
 - 100–1,000 \times HERA

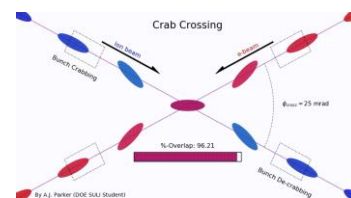
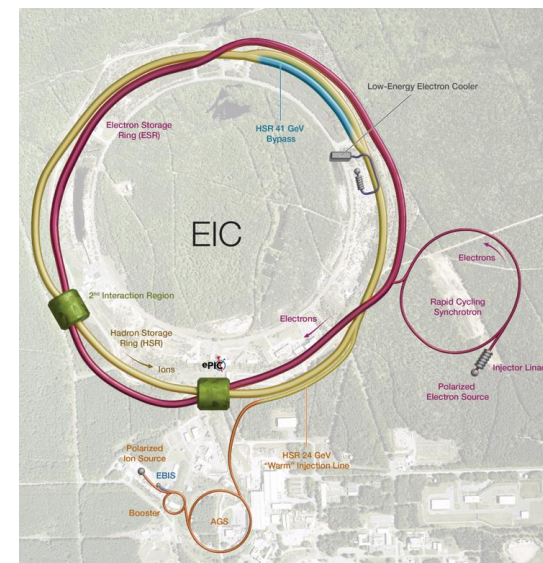
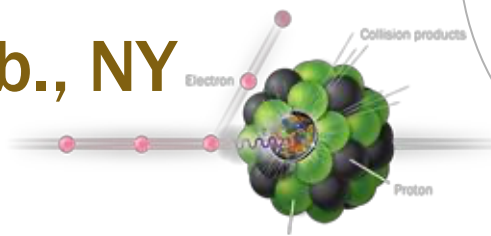

- physics data taking to start ~2035



Sweeping Away Mysteries of Hadron



■ origin of mass

- QCD trace anomaly \sim gluon condensate
- chiral symmetry breaking \sim quark pair condensate

■ origin of spin

- contributions from quarks, gluons, orbital motion

■ confinement

- inside pressure distribution

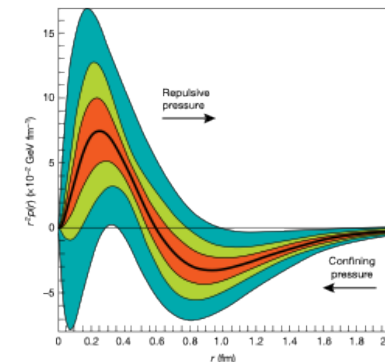
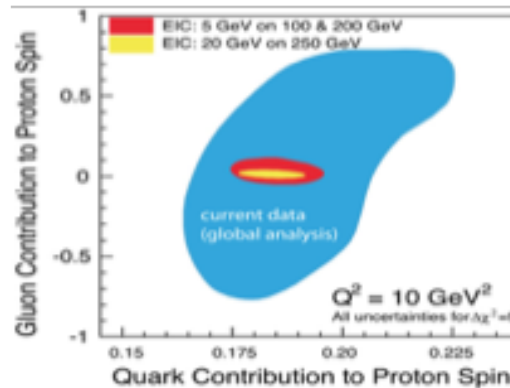
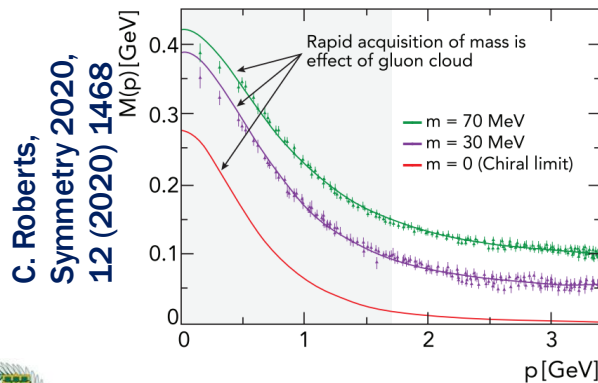

V. D. Burkert et al.,
Nature 557 (2018) 396



EIC Community



- EIC User Group formed in 2016
- 41 countries, 310 institutions, 1,558 members
 - significant presence of Asian countries
- <https://www.eicug.org/>

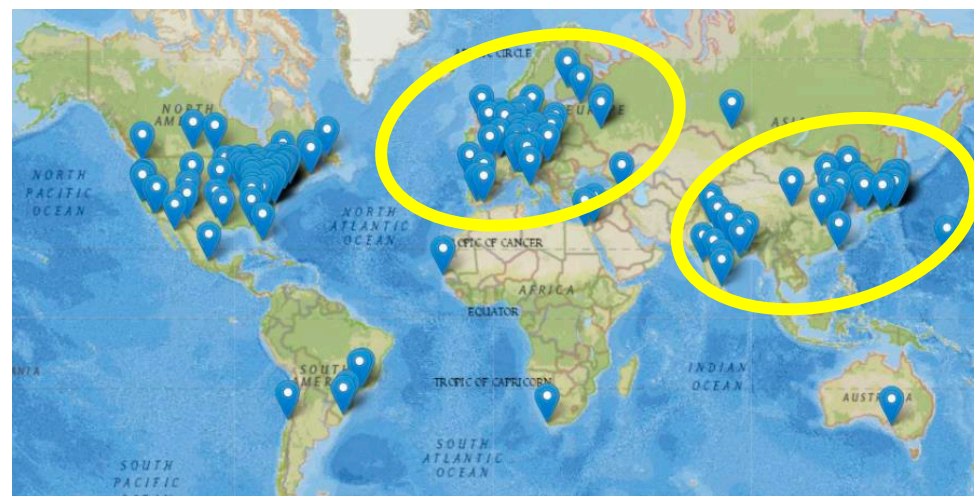
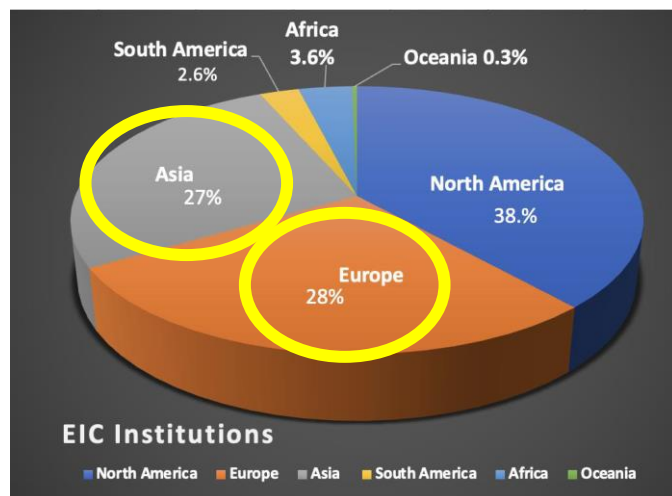

... and ePIC Collaboration



- ePIC detector collaboration initiated in 2022
- 26 countries, 183 institutions, 1,158 members
 - 3 + 13 institutes in France + Japan

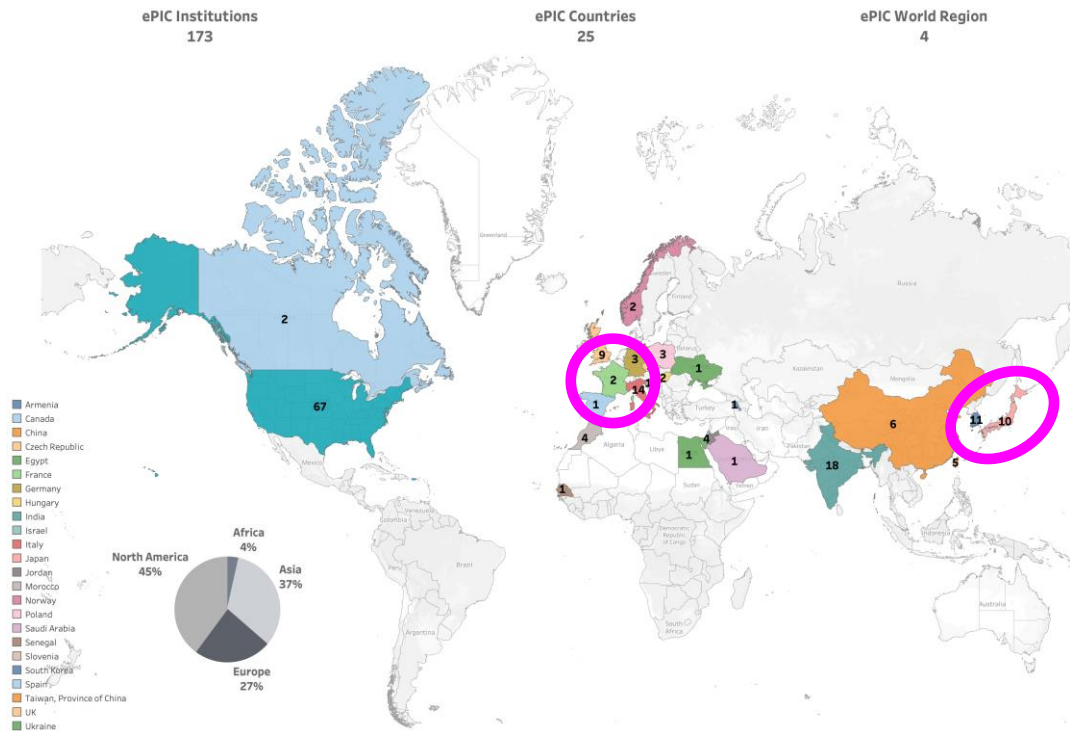

Two Time of Flight Systems for PID

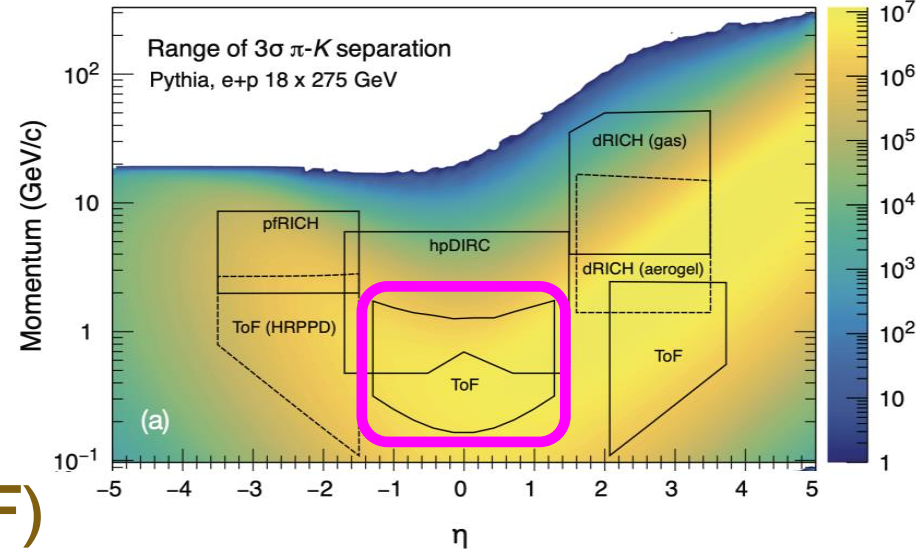
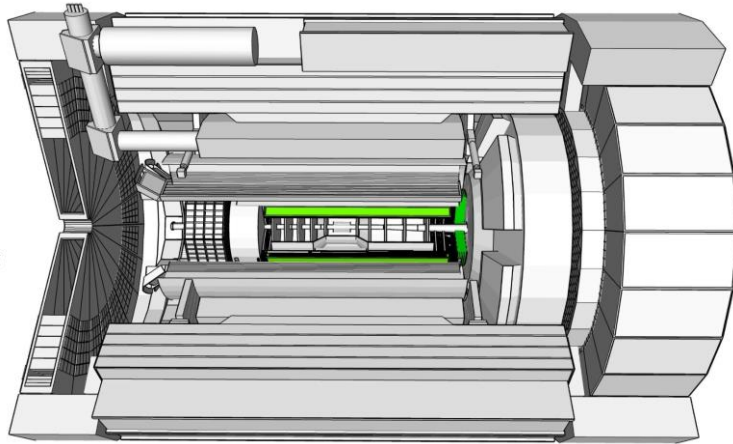

- barrel time of flight (bTOF)

- 3σ π /K/p separation in $0.2 < p < 1.2$ GeV/c
- AC-LGAD sensors with strip readout

- forward time of flight (fTOF)

- 3σ π /K/p separation in $0.2 < p < 2.3$ GeV/c
- AC-LGAD sensors with pixel readout



Strip AC-LGAD Sensor Development



- resolution goals: ~ 30 ps, ~ 30 μm (charge centroid)

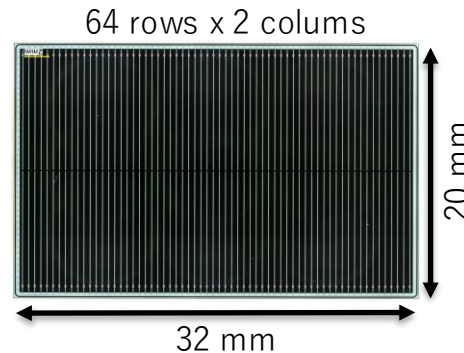

- **HAMAMATSU** test production \Leftrightarrow performance test
PHOTON IS OUR BUSINESS
 - sensor electrode geometry
 - timing resolution, position resolution
 - active layer thickness
 - timing resolution, signal strength
 - readout geometry
 - impact on overall detector design



Beam Tests at DESY/KEK/RARiS/...



- preliminary good timing/position performances

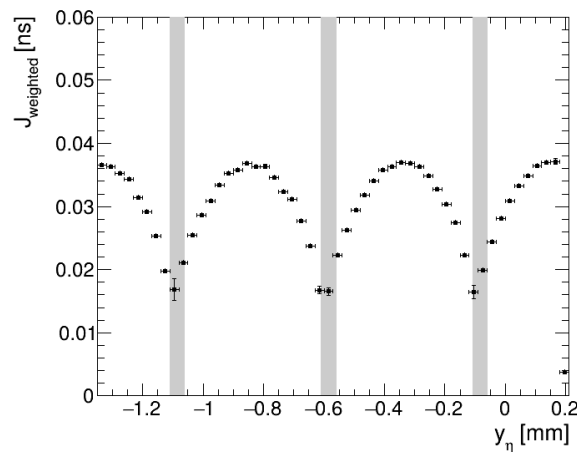
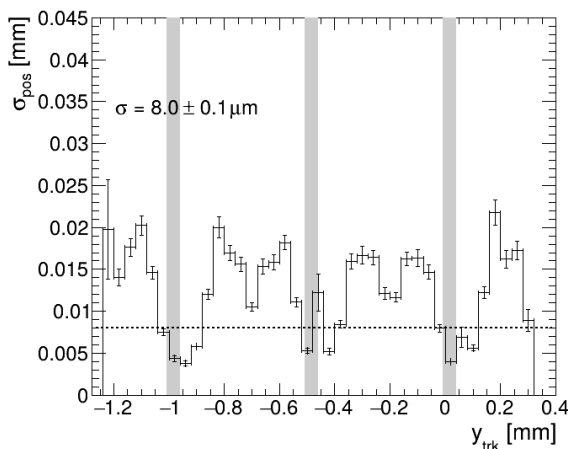

- 6 types of AC-LGAD tested at RARiS in 2026/03

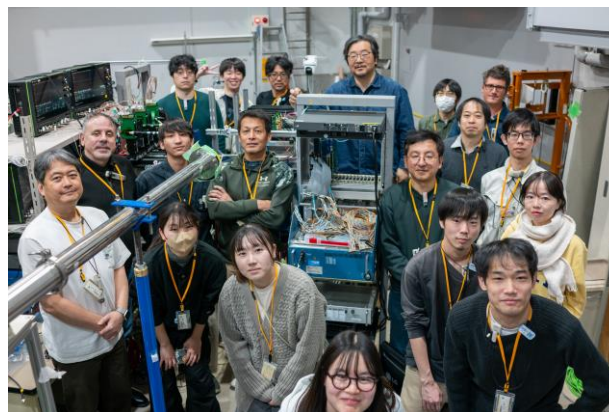
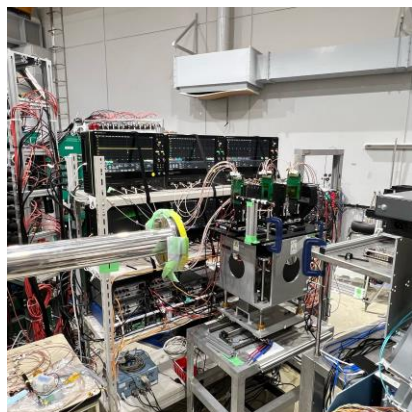

Readout ASIC Candidates

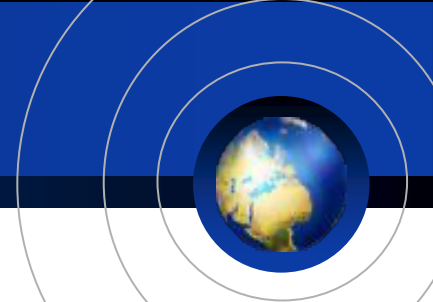

■ FCFD by FNAL (US)

- “official” first candidate for barrel ToF
- v.1.1 under tests

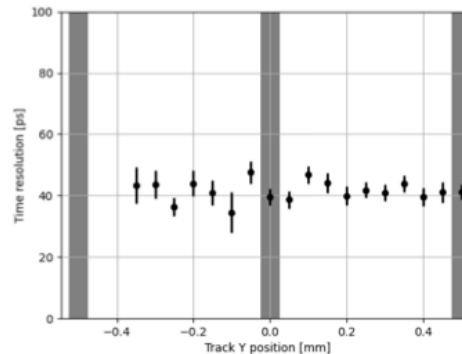
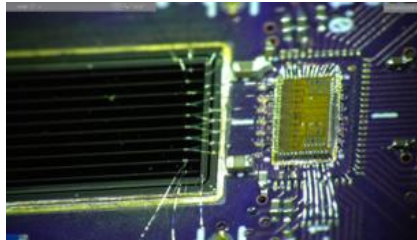

A. Apresyan et al.,
NIM A 1089,
171599 (2026)

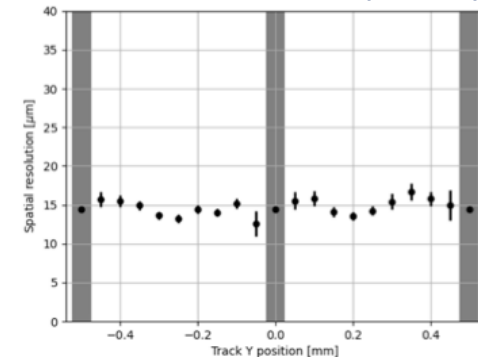

- v.1.2 (6 ch.) submitted (2026/04)
 - full functionality with TDC, ADC, I2C and simplified readout
- v.2: full size (32 ch.) final prototype (~2026/E)

■ CALOROC by Omega (France)

■ cf. EICROC by Omega (France)



CALOROC Development at Omega



- v.1 chips and test boards received (2026/02)
- v.1C variant with strip AC-LGAD in scope
 - for moderate sensor capacitance ~ 50 pF
- good preliminary performance

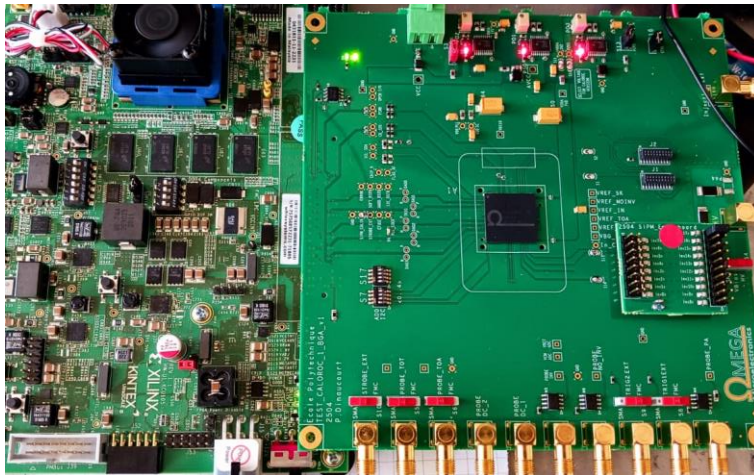

Signal vs time for channel 26 with a phase offset of 0

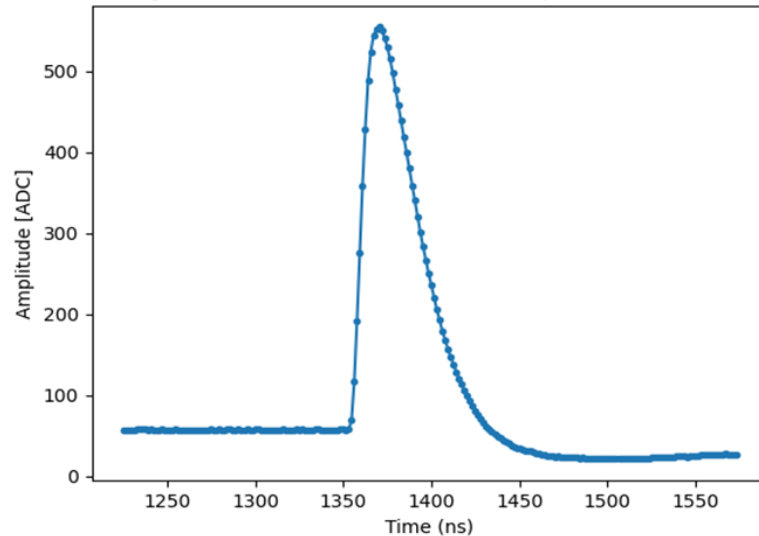

- v.2 for detector test, v.3 for production (2028)



EICROC Development at Omega



- 2-dim. layout for pixel AC-LGAD (e.g. roman pods)
- v.0 (2022), 0A, 0B (2025): 4×4 ch.

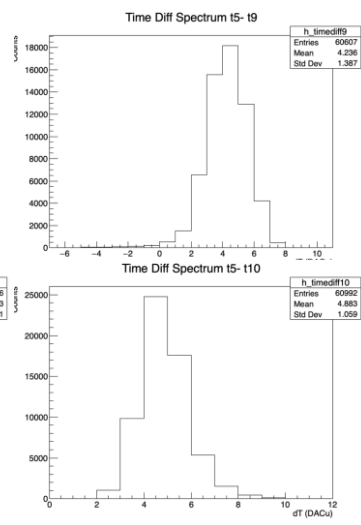
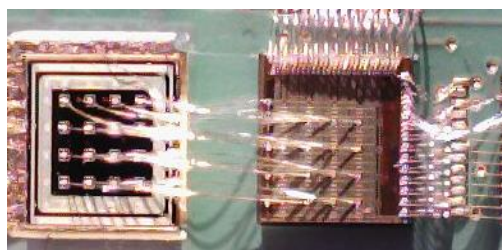

– pixel by pixel jitter 19–29 ps

- v.1 (2025): 32×32 ch.
- v.2 (2027): final prototype

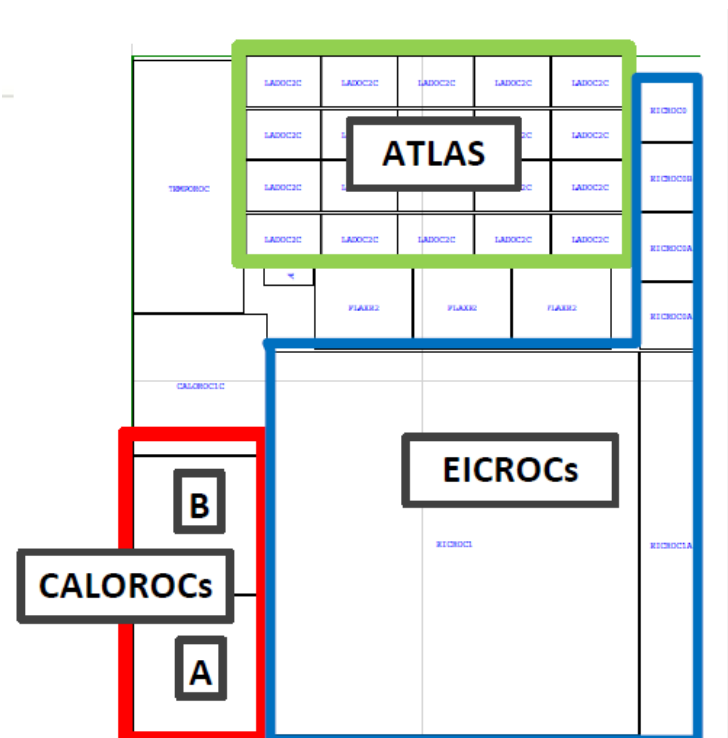

TYL/FJPPN 2025 Plans (Last May)

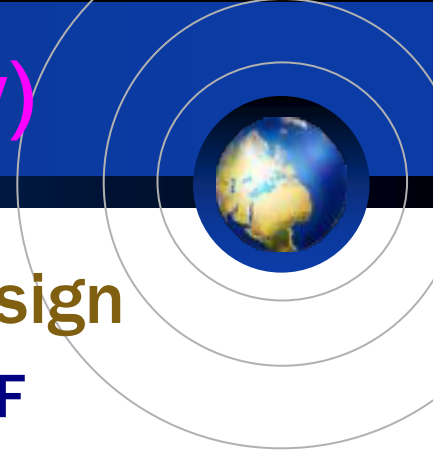

- from R&D to Preliminary Engineering Design
 - final technology choices on overall barrel TOF
- full chain test of module assemblies
 - AC-LGAD with various geometries and parameters
 - HPK and BNL prototypes at [Hiroshima U](#)
 - multiple readout ASICs with analog + digital parts
 - FCFD ver.2 by FNAL
 - CALOROC1C by [Omega](#)
- performance tests
 - e.g. temperature dependence
 - lab tests with β particles, IR laser
 - beam tests with protons (FNAL), electrons (ELPH)



19 May 2026

TYL/FJPPN D_RD_33: Strip AC-LGAD for EIC ePIC – C. de La Taille / K. Shigaki

12/19



TYL/FJPPN 2025 Achievements



- **continuing leading efforts on ePIC barrel TOF**
 - Japan taking major responsibilities
 - overall design, AC-LGAD sensor, structures
 - S. Yano (Hiroshima) as deputy detector subsystem lead
 - France perfectly covering “Achilles' heel”
 - readout ASIC
 - PhD candidates at Ecole Polytechnique and Hiroshima U.
- **visit to Omega rescheduled to 2026 2/3Q**
 - due to semiconductor delays (CALOROC1C)
 - external supports (à la FJPPN) greatly appreciated
- **brand new clean rooms at Hiroshima U.**



Clean Rooms Launched at Hiroshima



- part of new WPI-SKCM² building
- >100 m²; class 10,000 certified (operated ~1,000)



- primarily assigned to K. Shigaki
 - first project: ePIC barrel TOF test/construction site



TYL/FJPPN 2026 Plans

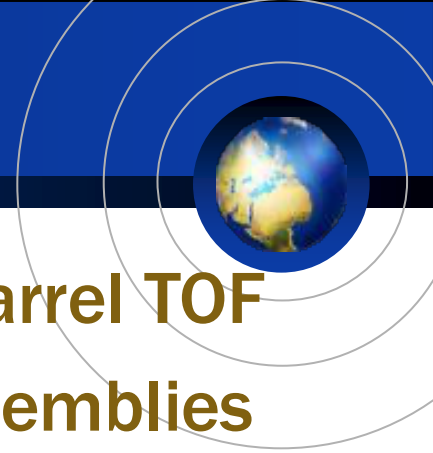

- final technology choices and design of barrel TOF
- near-final prototypes of components/assemblies
 - strip AC-LGAD geometries and parameters
 - HPK prototypes at [Hiroshima U.](#)
 - readout ASICs with analog and digital parts
 - FCFD ver.1.2 by FNAL coming in Summer 2026
 - CALOROC1C by [Omega](#) under initial tests
- continuing performance tests
 - e.g. temperature dependence
 - lab tests with β particles, IR laser
 - beam tests with protons (CERN), electrons (ELPH)





- **Ecole Polytechnique, Omega/IN2P3**
 - leading roles in ePIC readout ASIC development



- **CALOROC, EICROC, HGCROC (de La Taille)**

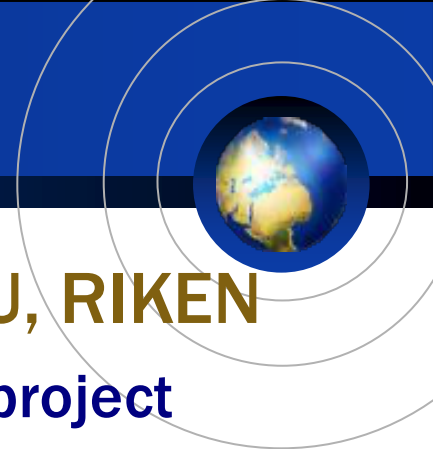

- Hiroshima U, Shinshu U, Nara Women's U, RIKEN
 - leading roles in many aspects of barrel TOF project



- test/production facility (Shigaki)
- project coordination, sensor (Yano)
- database, simulation, software, calibration (Kawade)
- system test and validation (Hachiya)
- infrastructure (Gunji, Goto)

Promoting Young Generation

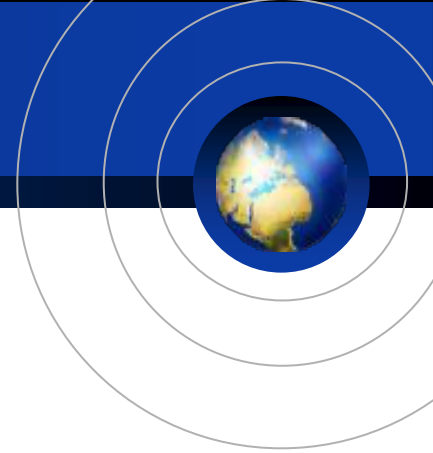

- **joint PhD student supervision**
 - A. Verplancke (Ecole Polytechnique)
 - K. Matsutani (Hiroshima U.)
 - T. Saito (from 2028, Hiroshima U.)
- **new PD joining ePIC barrel TOF project**
 - A. Ikbal (from 2026/08, Hiroshima U.)



readout ASIC



sensor evaluation



sensor bonding

NEW



NEW



Summary and Concluding Remarks



- **ePIC bTOF with AC-LGAD for PID in low- to mid- p_T**
 - excellent 4-dim. resolution (~ 30 ps, ~ 30 μm) required
 - strip type for moderate granularity
- **2024–2027 vitally important for ePIC barrel TOF**
 - R&D and near-final prototyping due in 2026
 - full detector chain design close to complete
- **France–Japan(–US) collaboration essential**
- **TYL/FJPPN support very effective for us**
 - tight collab. including PhD students and postdocs
 - face-to-face meetings in France and/or Japan
 - hearty appreciation to the committee

