

ON THE WAY TO MEASURE MID-T SAMPLES WITH THE QUADRUPOLE RESONATOR (QPR)

Carl Weiß, MSc student - on behalf of the SRF R&D Team
19.3.2026 | TTC remote meeting on high-Q/high-G

HELMHOLTZ



Universität Hamburg
DER FORSCHUNG | DER LEHRE | DER BILDUNG



Why do we need a QPR?

- **economic** step between material sample and cavity
- RF characterization and material studies **on same surface**
- Calculation of **material properties at different settings**
 - 420 MHz, 850 MHz and 1.3GHz (Q1, Q2, Q3)
 - Temperature 1.5-30K with independent heating
 - Up to 100 mT \approx 25 MV/m

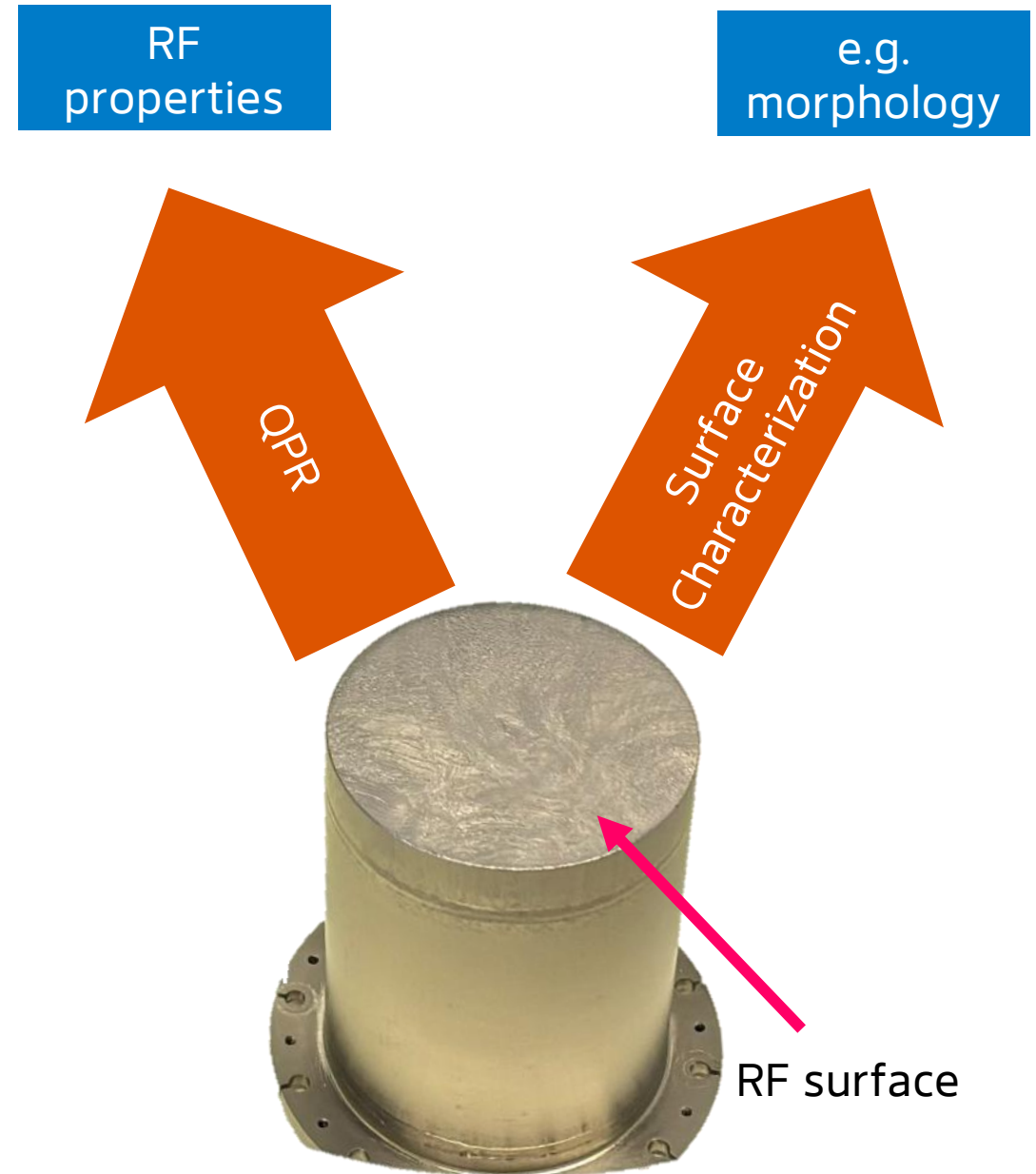

General setup

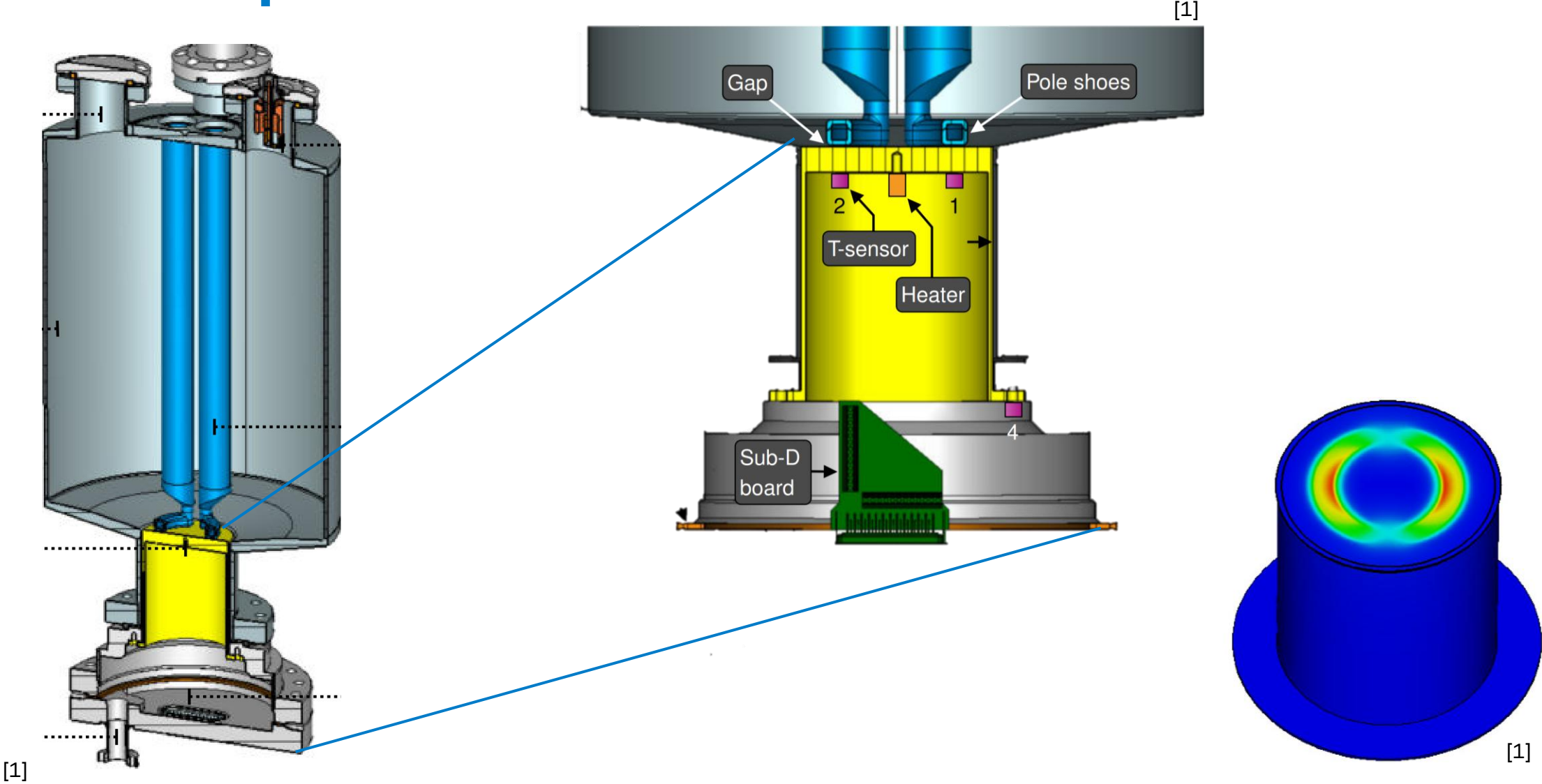

Directly measure the RF losses on the sample

1. Heat sample to specific temperature
2. Turn on RF power
3. Wait for stability at same temperature
4. Compare heater power for the states RF on and RF off

- $\Delta P_{DC} = |P_{DC1} - P_{DC2}|$
- $P_{diss} = \frac{1}{2} \int R_s H^2 dA$ (Joules Heating)



$$R_s = \frac{2c_1\mu_0^2}{c_2} \cdot \frac{\Delta P_{DC}}{U}$$

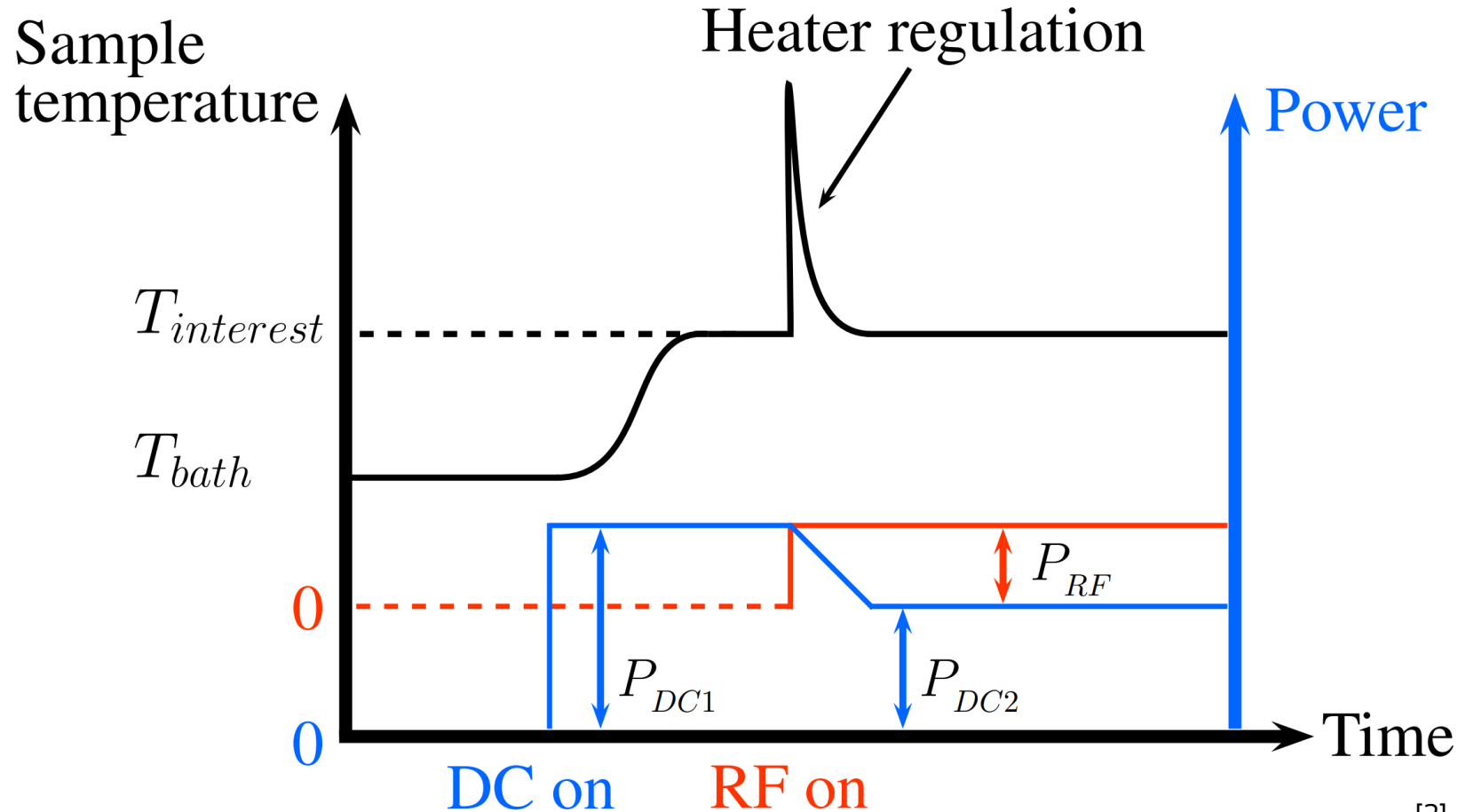

[2]

Track resonance peaks while heating up the sample over T_C

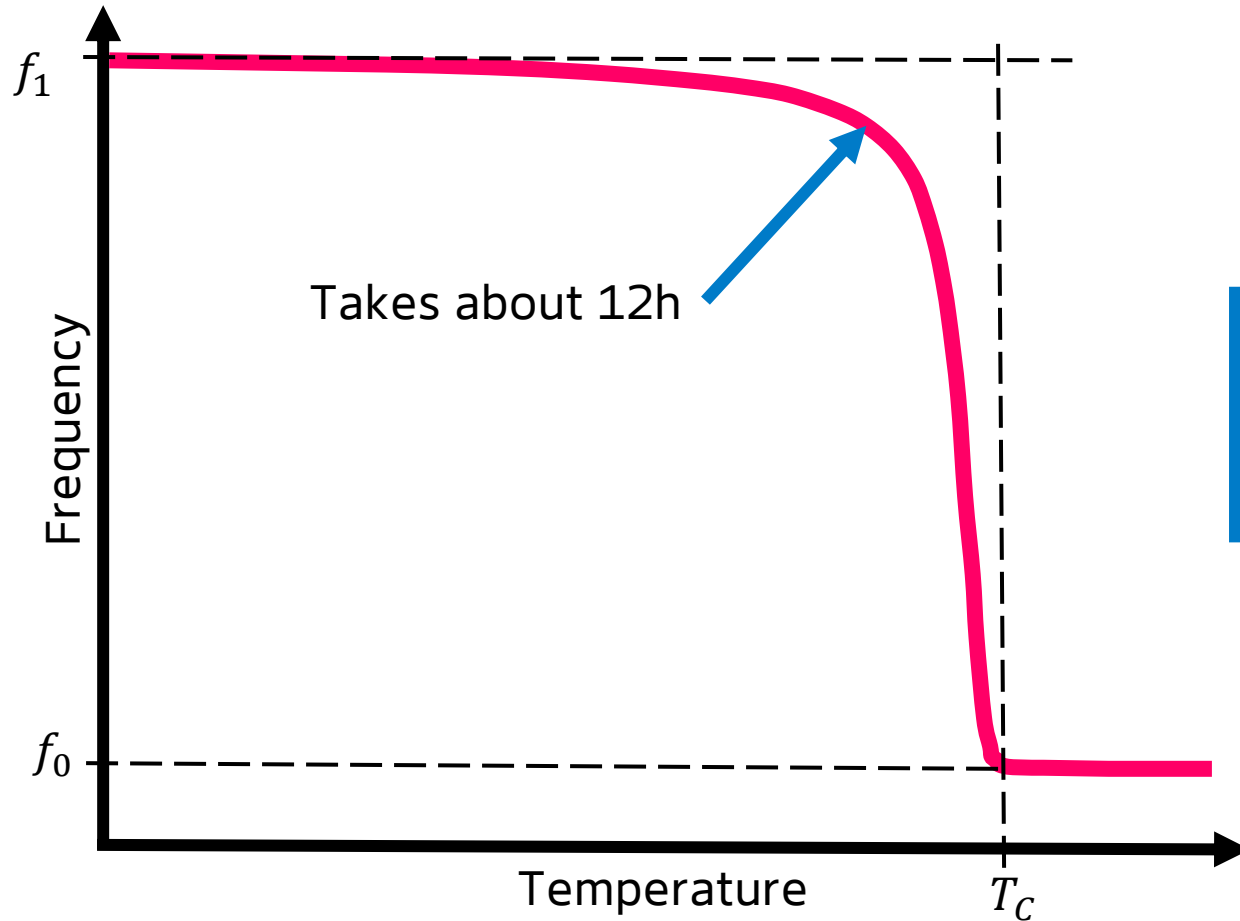

- London and effective penetration depth $\lambda(T)$ and $\lambda(0)$
- Mean free path l
- Superconducting Gap Δ and Dynes parameter, when also using $Q_0(T)$

Mid-T in the QPR?

- Mid-T = heat treatment at 250-350°C for 3-20 hours in an UHV
- Native Oxide dissociates and diffuses into Nb, thus enriching it with **interstitial oxygen**
- **Reduced R_s** over all, plus **Anti-Q-slope**
- For 1.3GHz cavity well known
 - $Q_0 \approx 2 \dots 5 \cdot 10^{10}$ @16 $\frac{\text{MV}}{\text{m}}$ see [10]
- Not well researched at lower frequencies

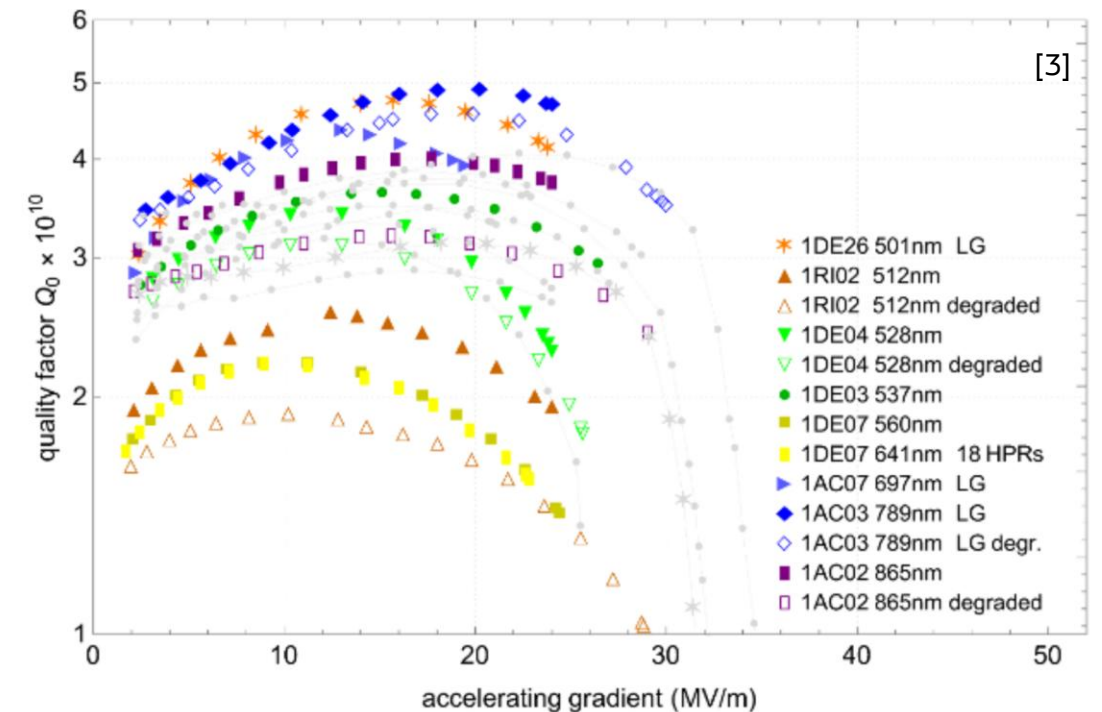
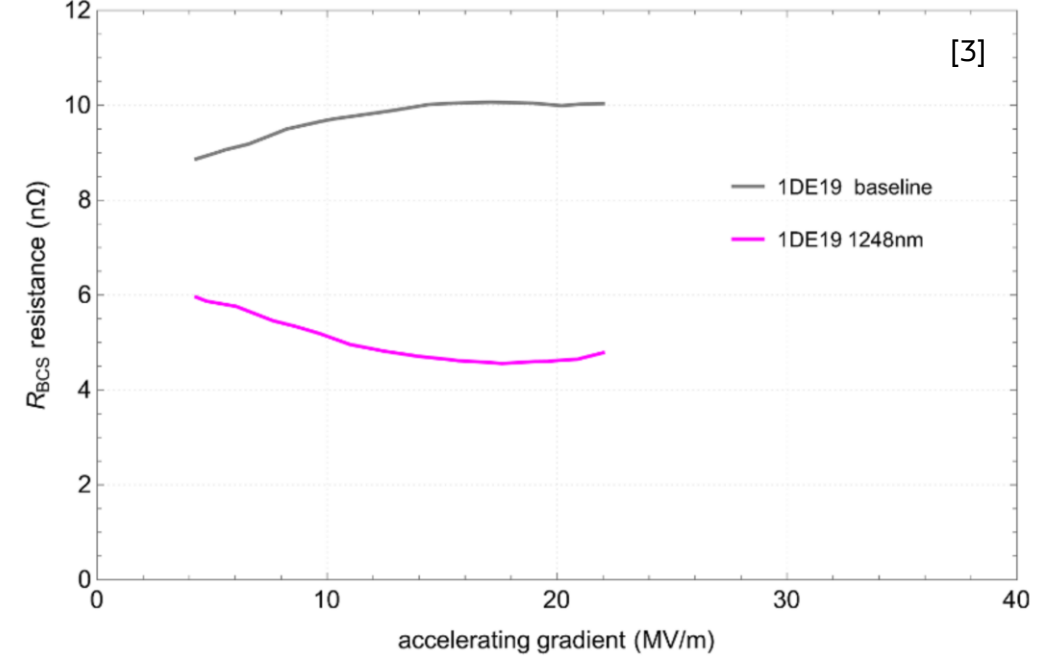

N-doping at different frequencies

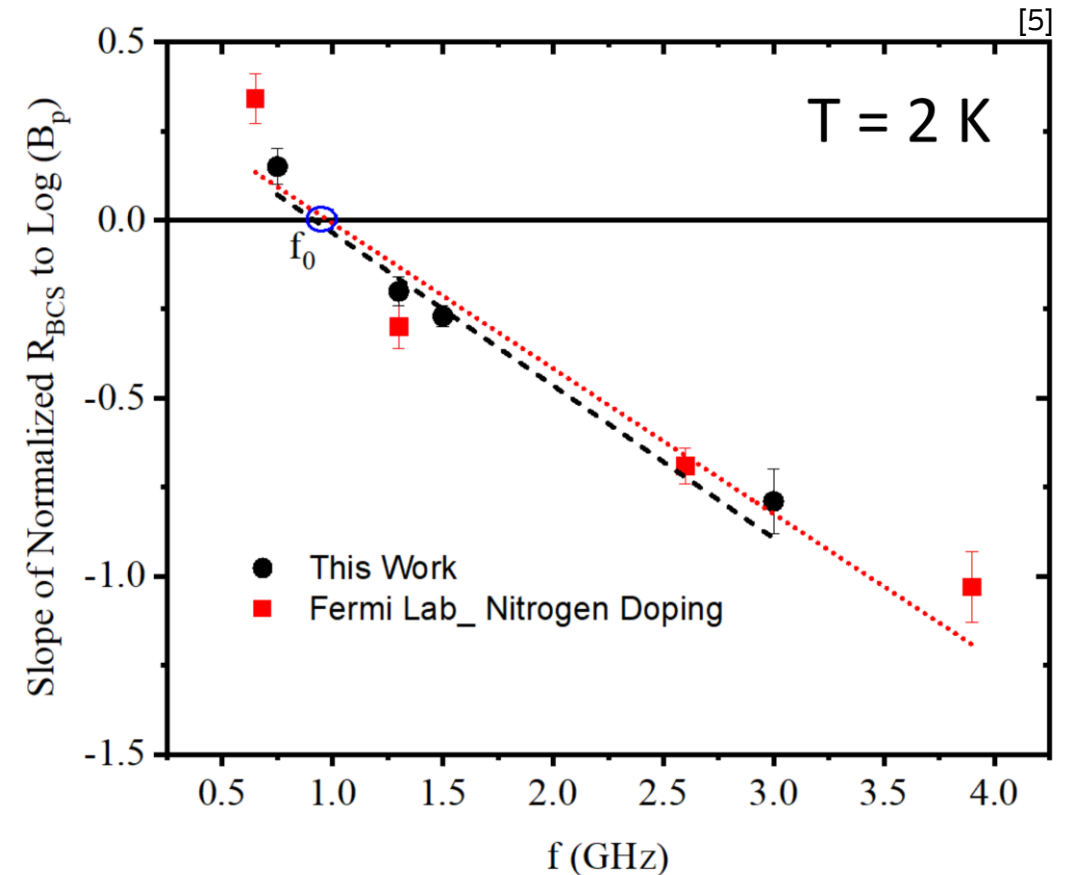
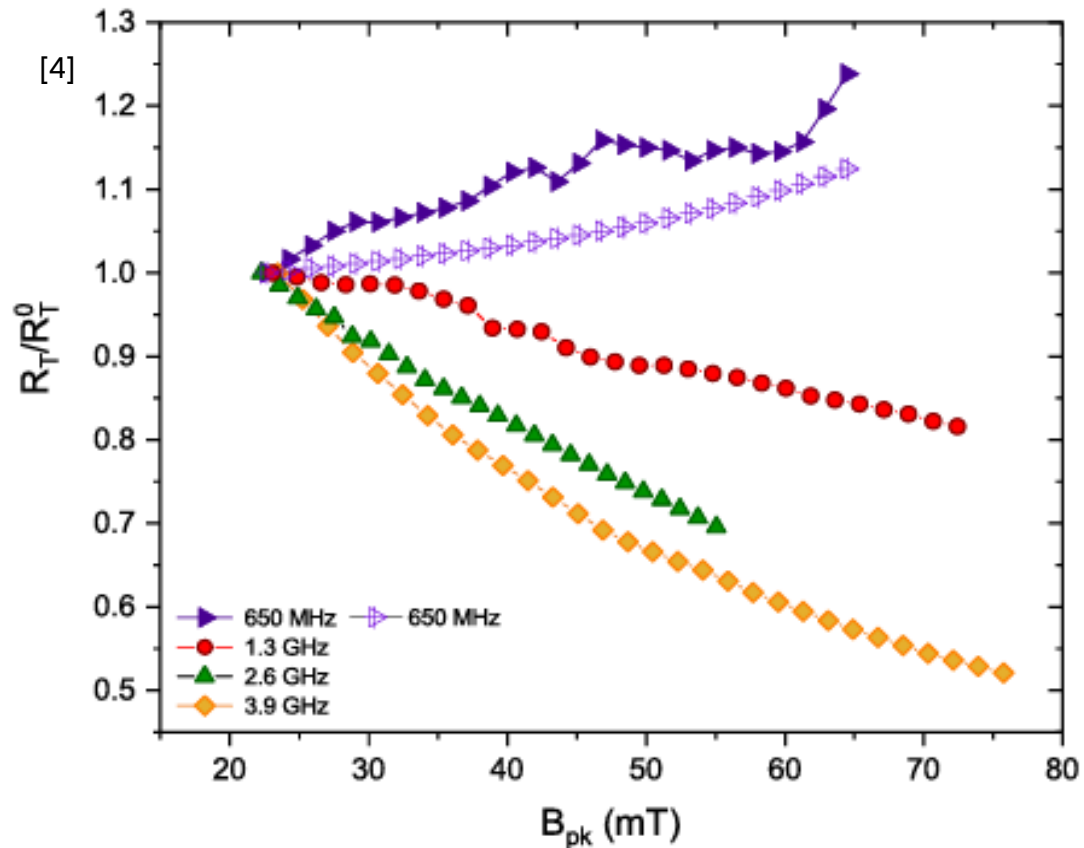

- N-doping shows no Anti-Q-slope for lower frequencies
- Q-slope threshold frequency at 900MHz (theory: "slow/fast-superconductor", "quasi-particle heating")
- same mechanisms cause Anti-Q-slope after Mid-T treatment

N-doping at different frequencies

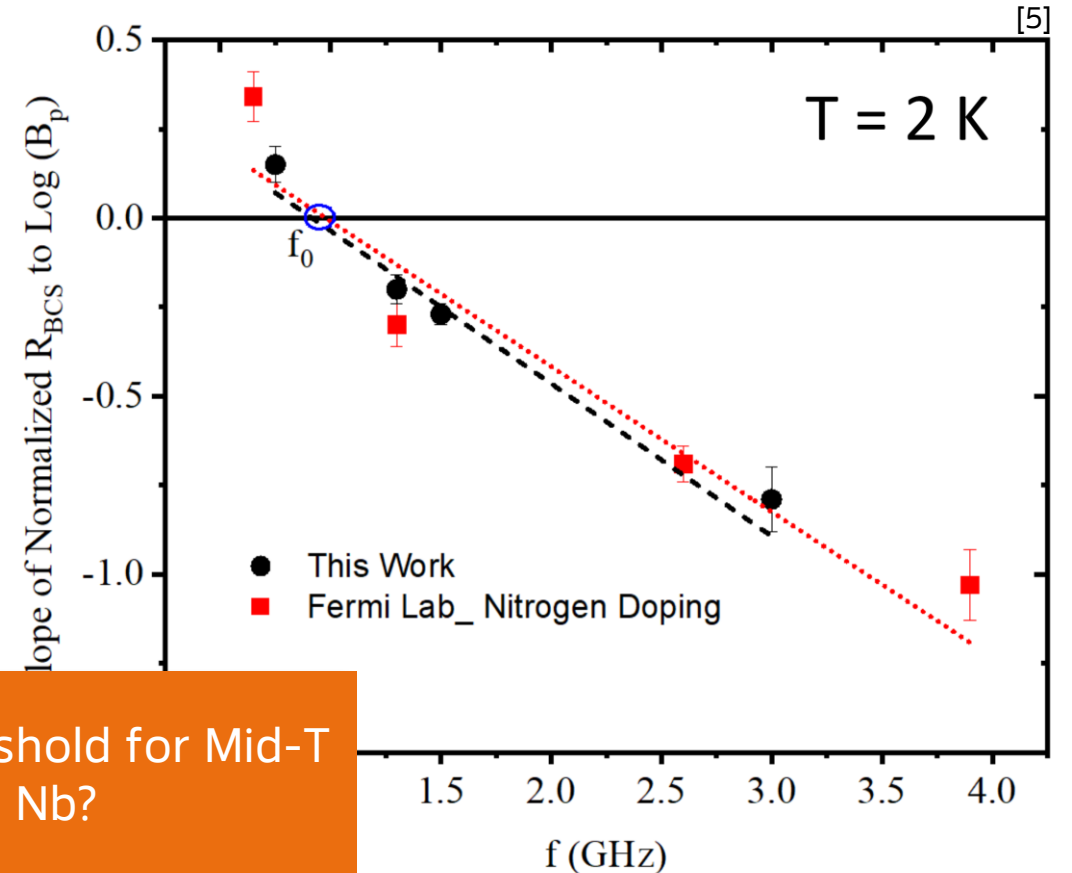
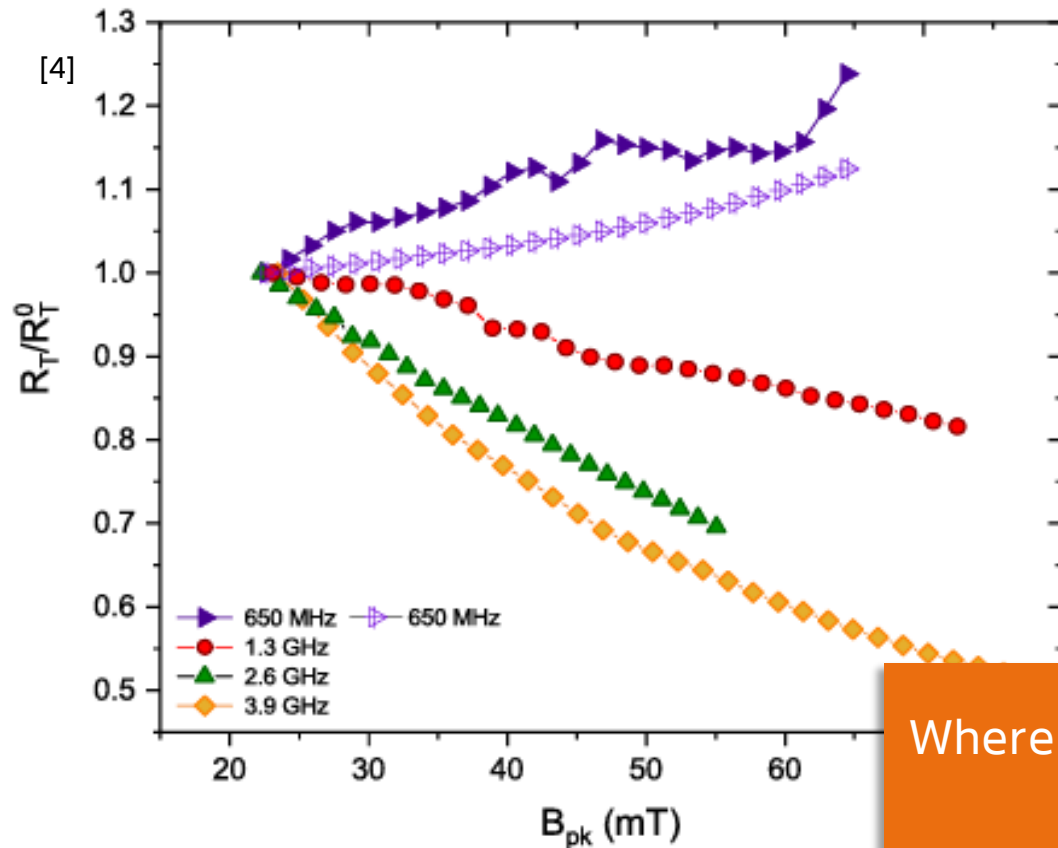

Where is the threshold for Mid-T treated Nb?

- N-doping shows no Anti-Q-slope for lower frequencies
- Q-slope threshold frequency at 900MHz (theory: "slow/fast-superconductor", "quasi-particle heating")
- same mechanisms cause Anti-Q-slope after Mid-T treatment

Mid-T in f vs T measurements

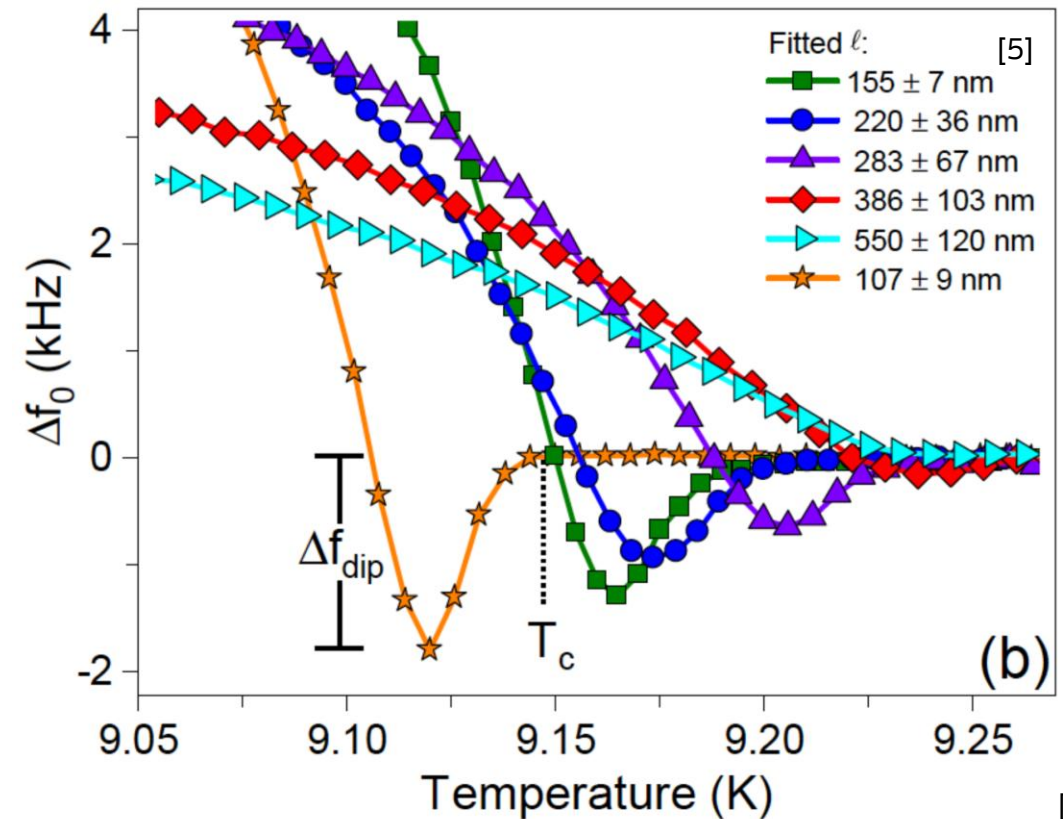
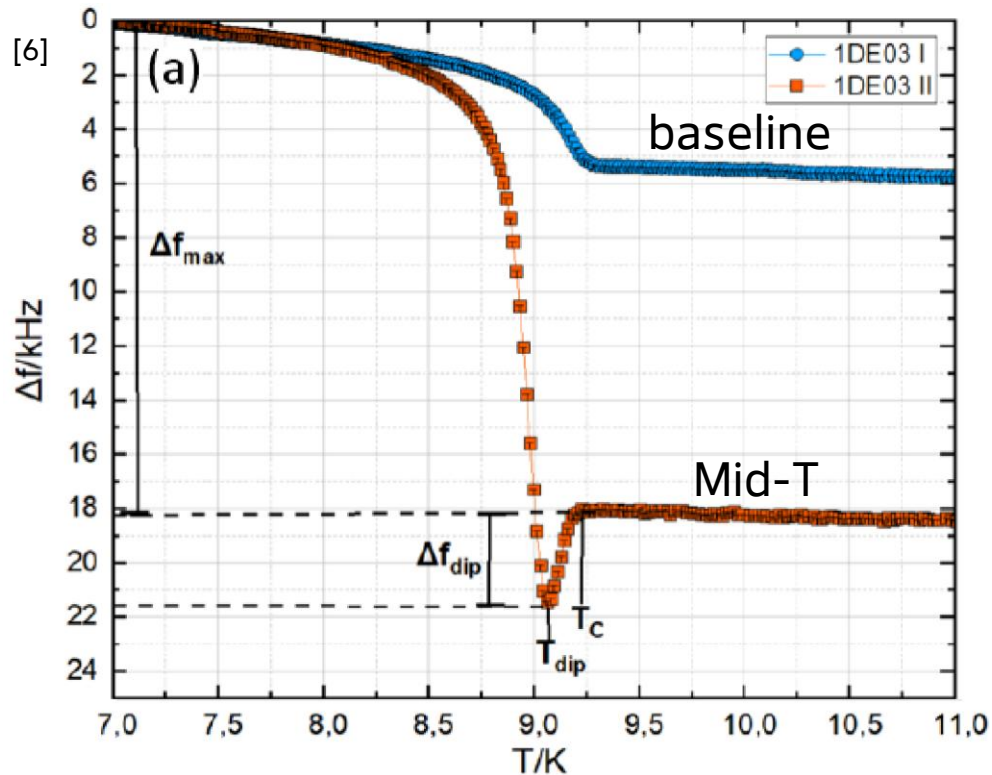

- Frequency shift gets larger over all
- A "Dip" just below T_c occurs
 - Size and shape depends on mean free path l
- Measurements on lower frequencies are missing

Will there be a dip at lower f ?
How is its shape?

Tested samples



Nb₃Sn:

- 1μm sputtered on Nb @INFN
- $T_C \approx 18K$
- Loaned from HZB

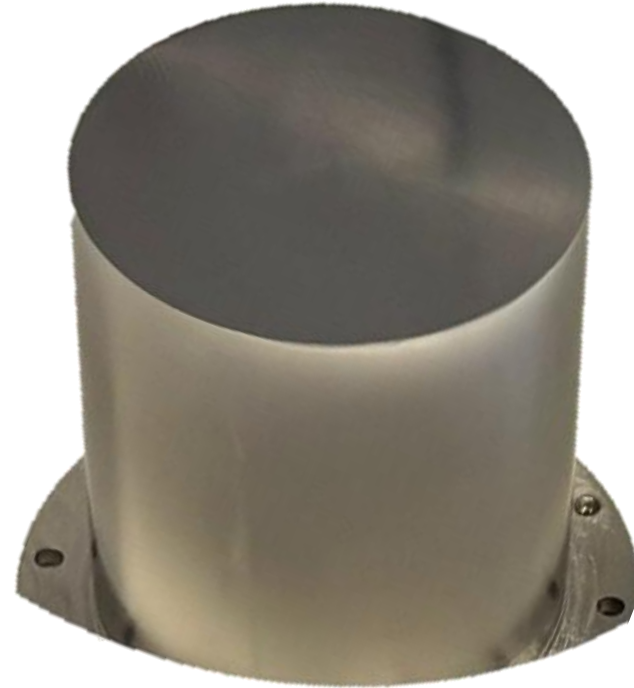

Nb E06 baseline

- $T_C \approx 9K$
- Surface treatments:
 - 10μm BCP (full sample) @ IJCLab
 - Bulk EP 330μm @CEA
 - 900°C annealing, 3h
 - Light EP 11μm @CEA



First sample measured with 2 different QPRs

Nb₃Sn - R_s vs T

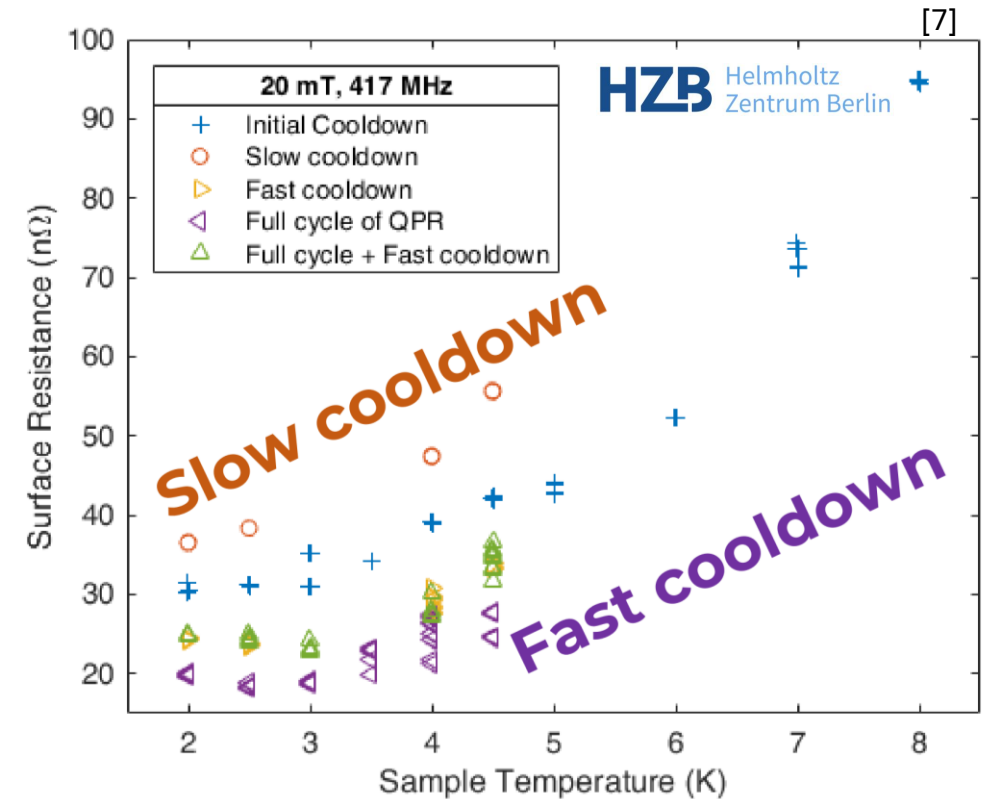
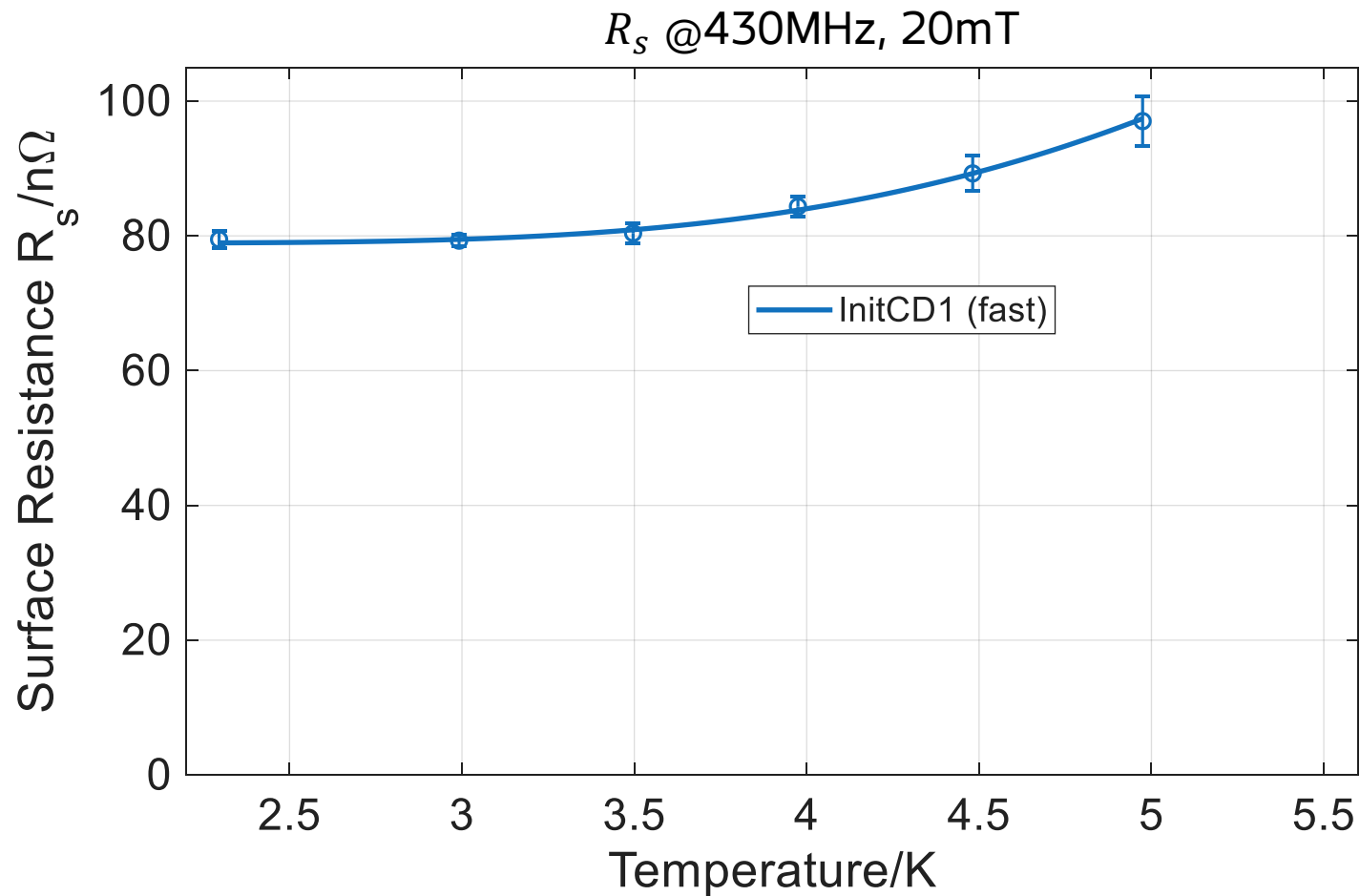

Cooldowns – Nb₃Sn

- Initial cooldowns with the full cryostat give a reset for R_s

cooldowns	$\frac{dT_3}{dt}(T_c)/\frac{\text{K}}{\text{min}}$	Note
InitCD1	24 ± 2	From 300K down
InitCD2	4.2 ± 0.2	From 300K down

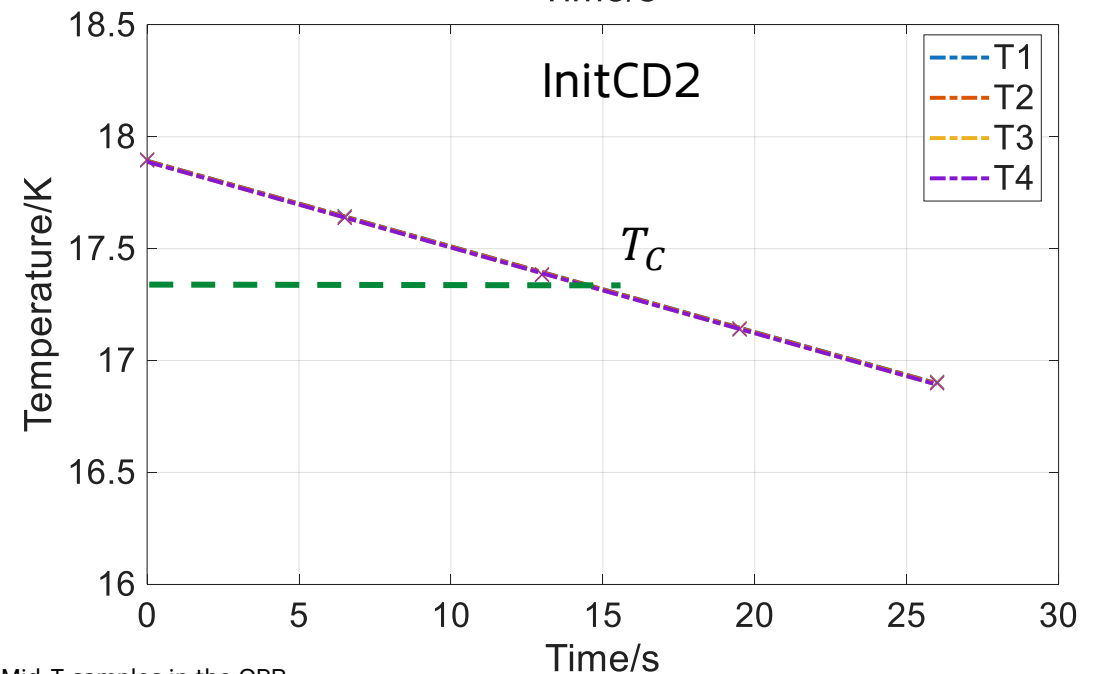
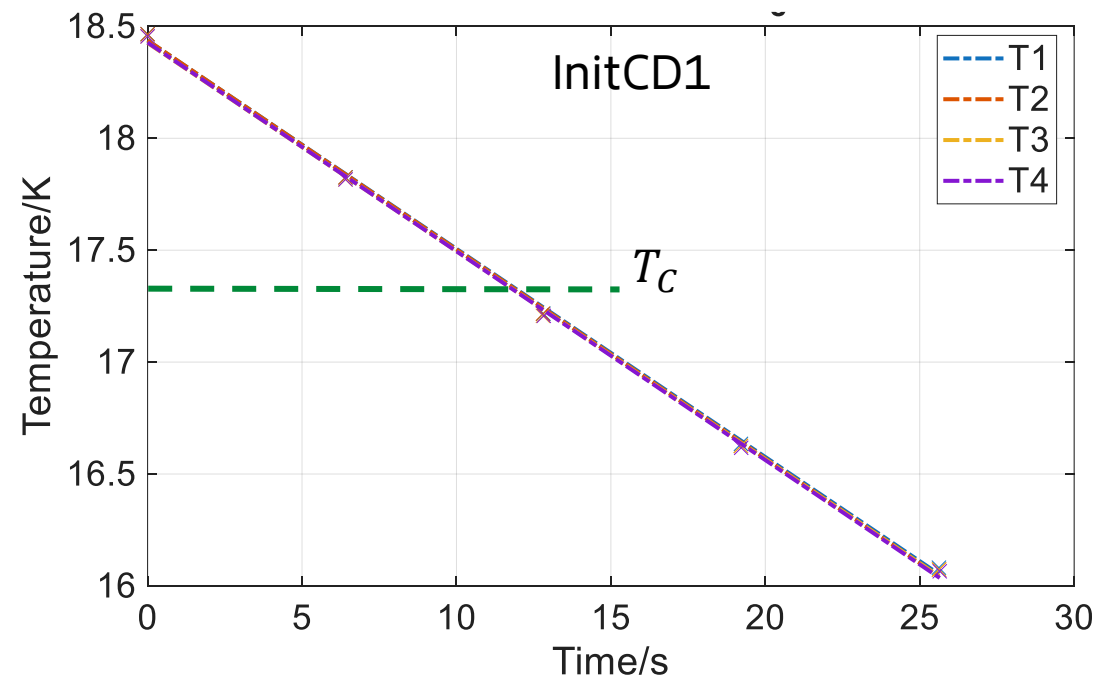

First sample measured with 2 different QPRs

Nb₃Sn - R_s vs T

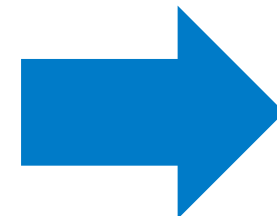
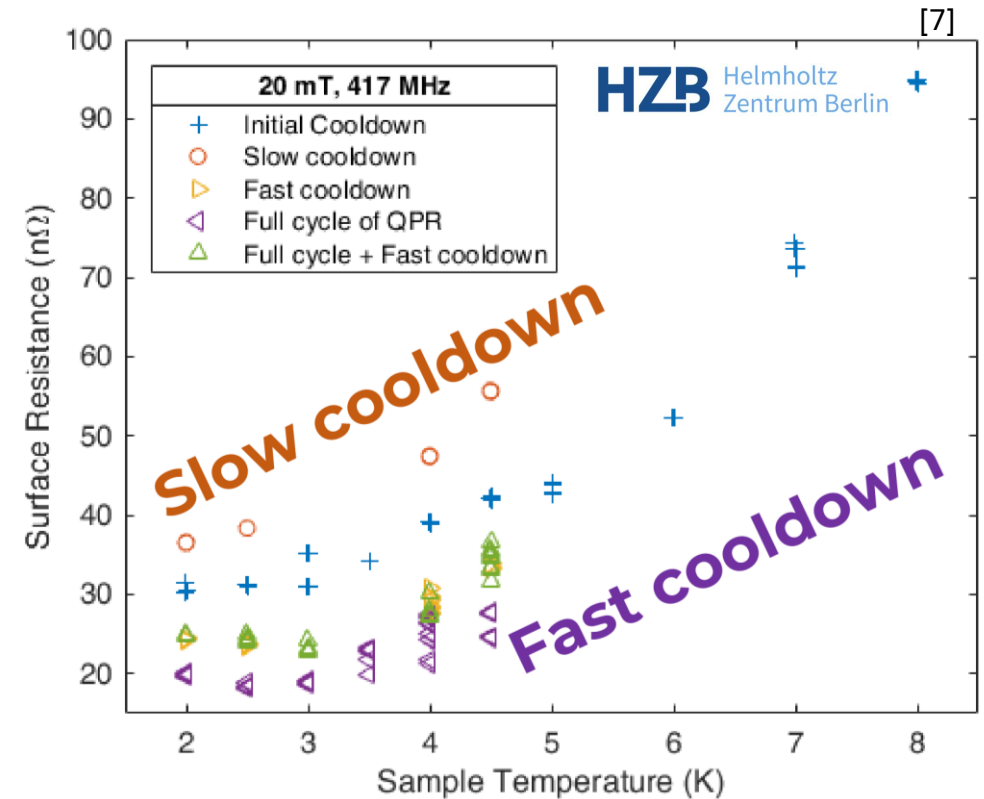
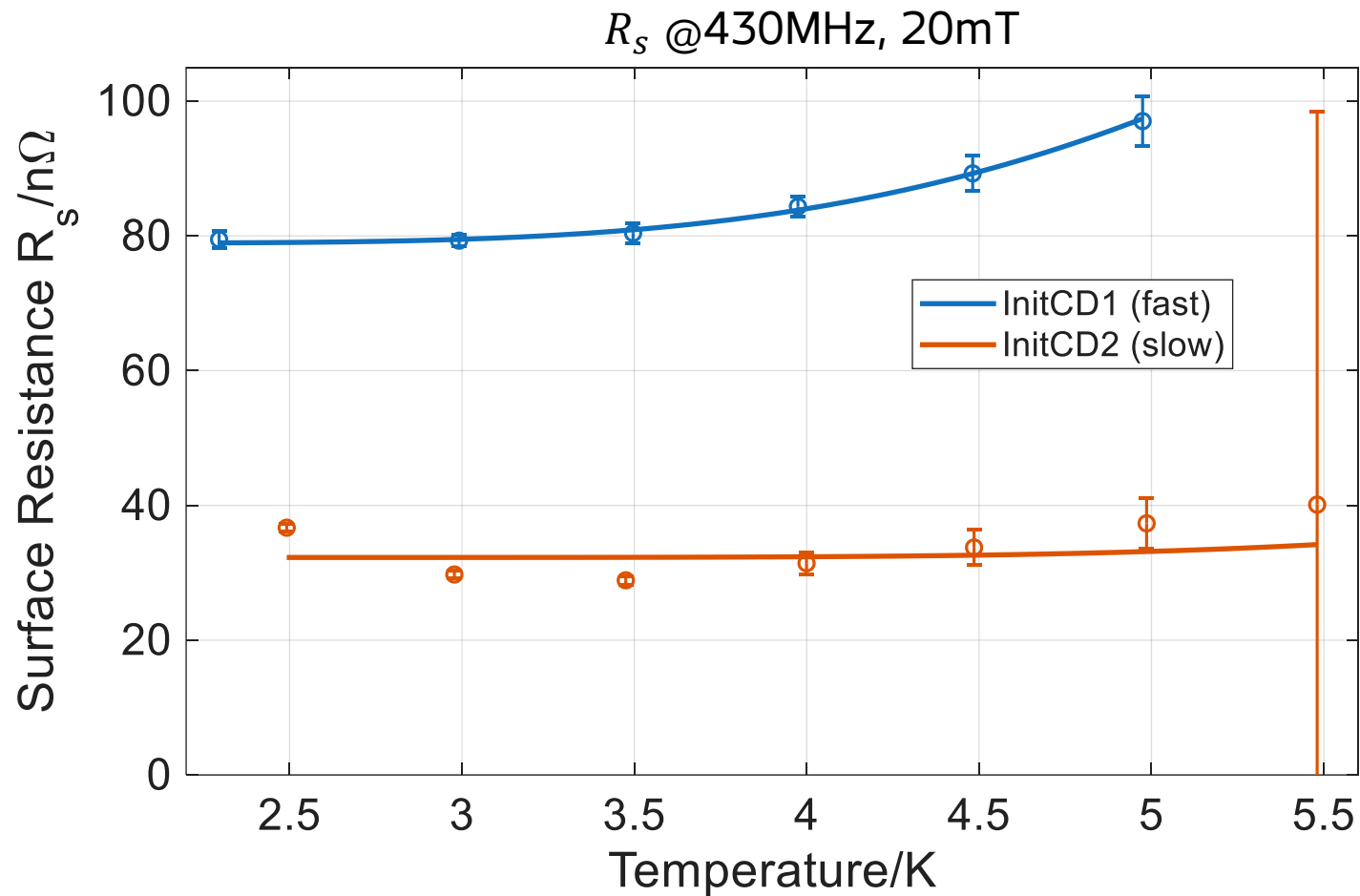

30nΩ @3K, 20mT
for 2 different QPRs

Cooldowns – Nb

- Performed a wide range of different gradients

cooldowns	$\frac{dT_3}{dt}(T_c)/\frac{\text{K}}{\text{min}}$	Note
InitCD1	11.5 ± 0.5	From 300K down
fastCD1	4.2 ± 0.2	Sample to 10K
slowCD1	1.13 ± 0.05	sample to 11K
slowCD2	1.15 ± 0.05	sample to 11K
InitCD2	0.04 ± 0.01	Full cryostat to 30K
SlowCD3	1.10 ± 0.05	sample to 11K
fastCD2	4.0 ± 0.2	Sample to 10K

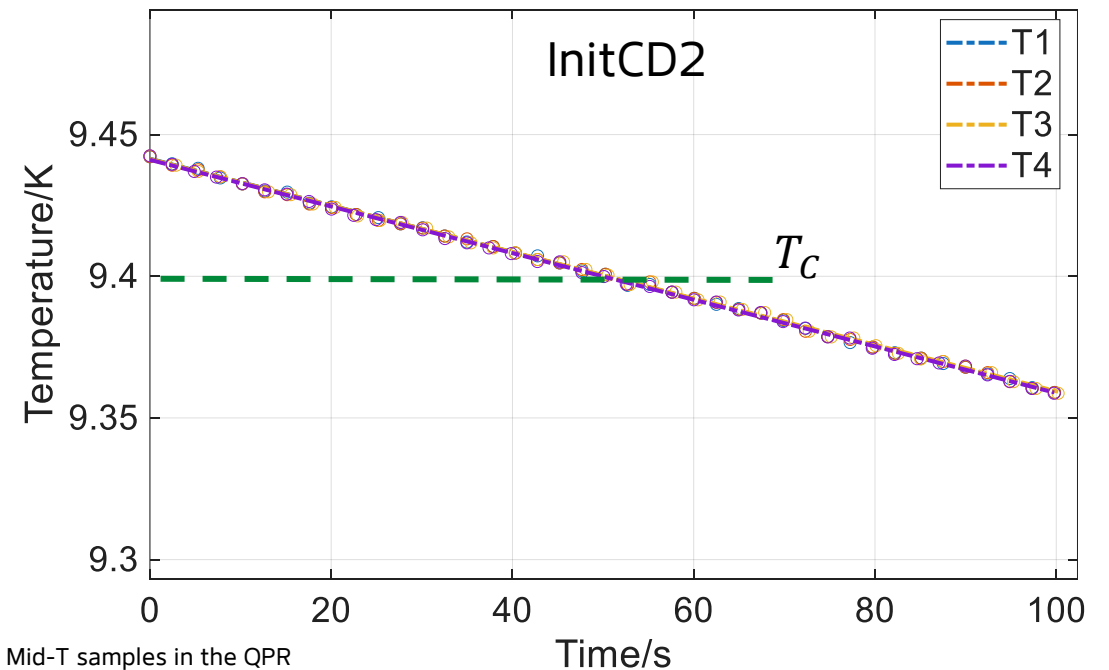
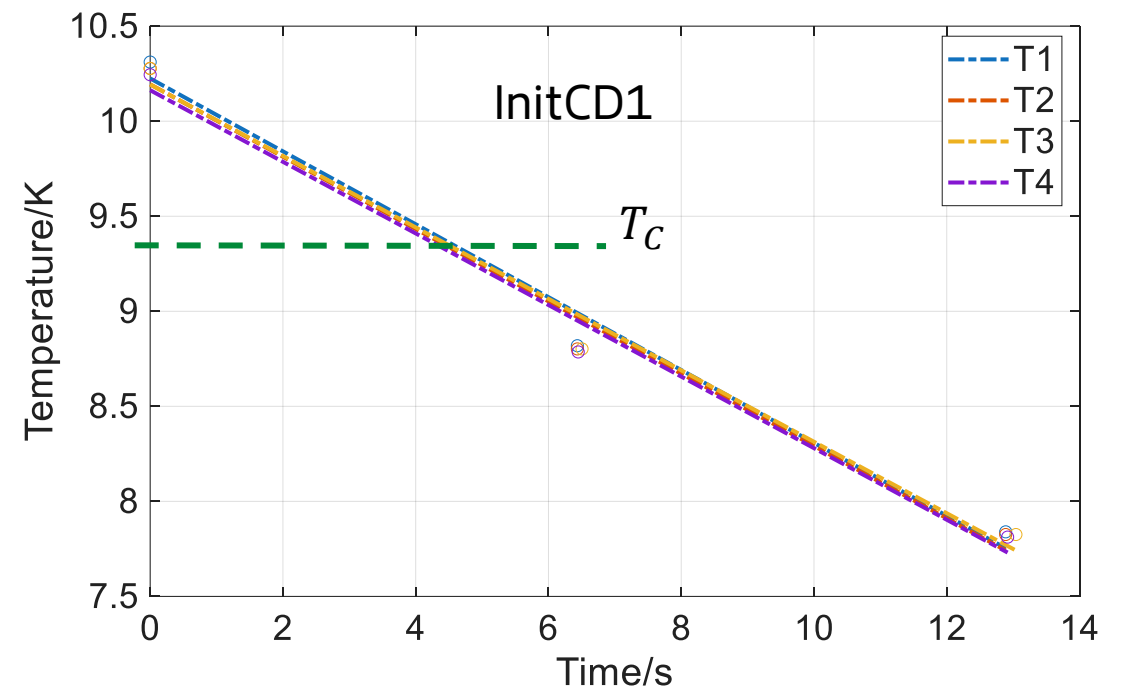

Nb - R_s is less sensitive to cooldown gradients

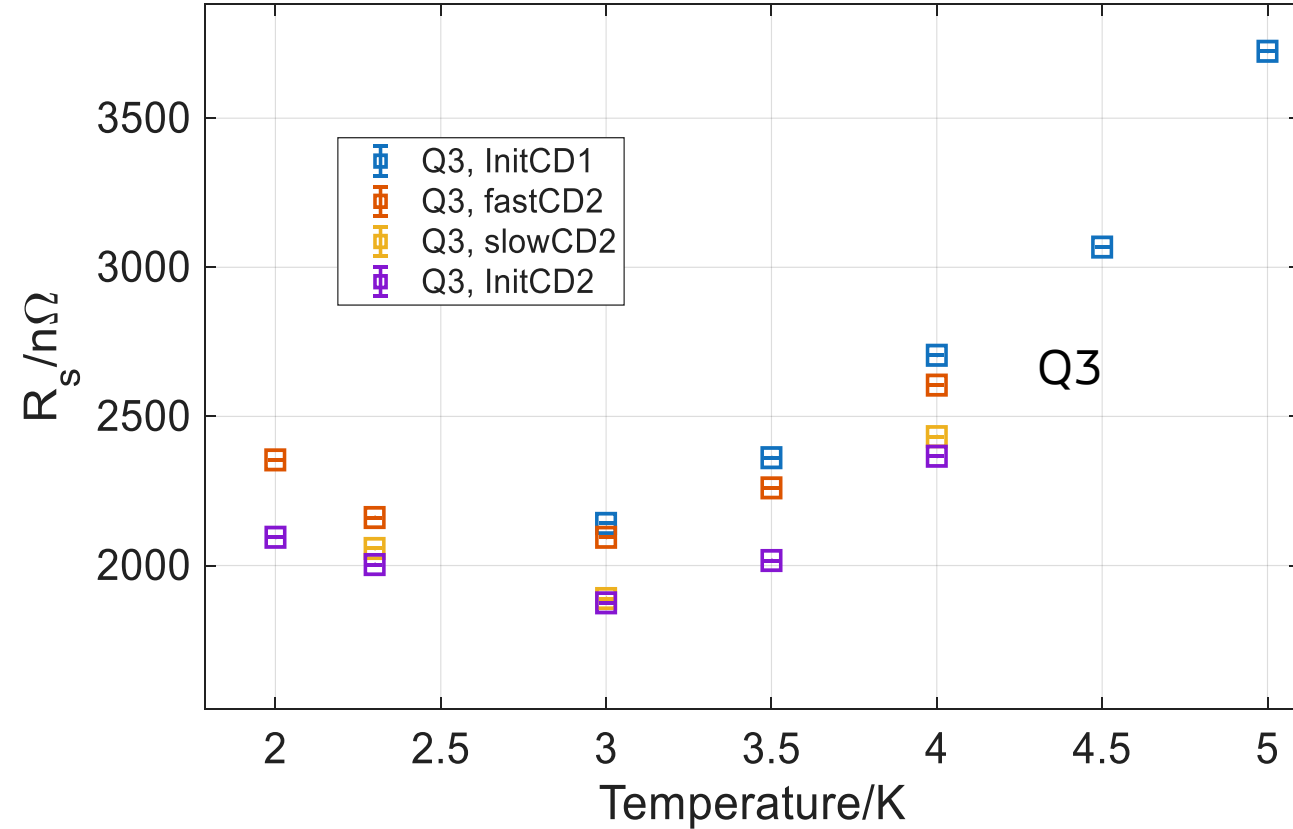
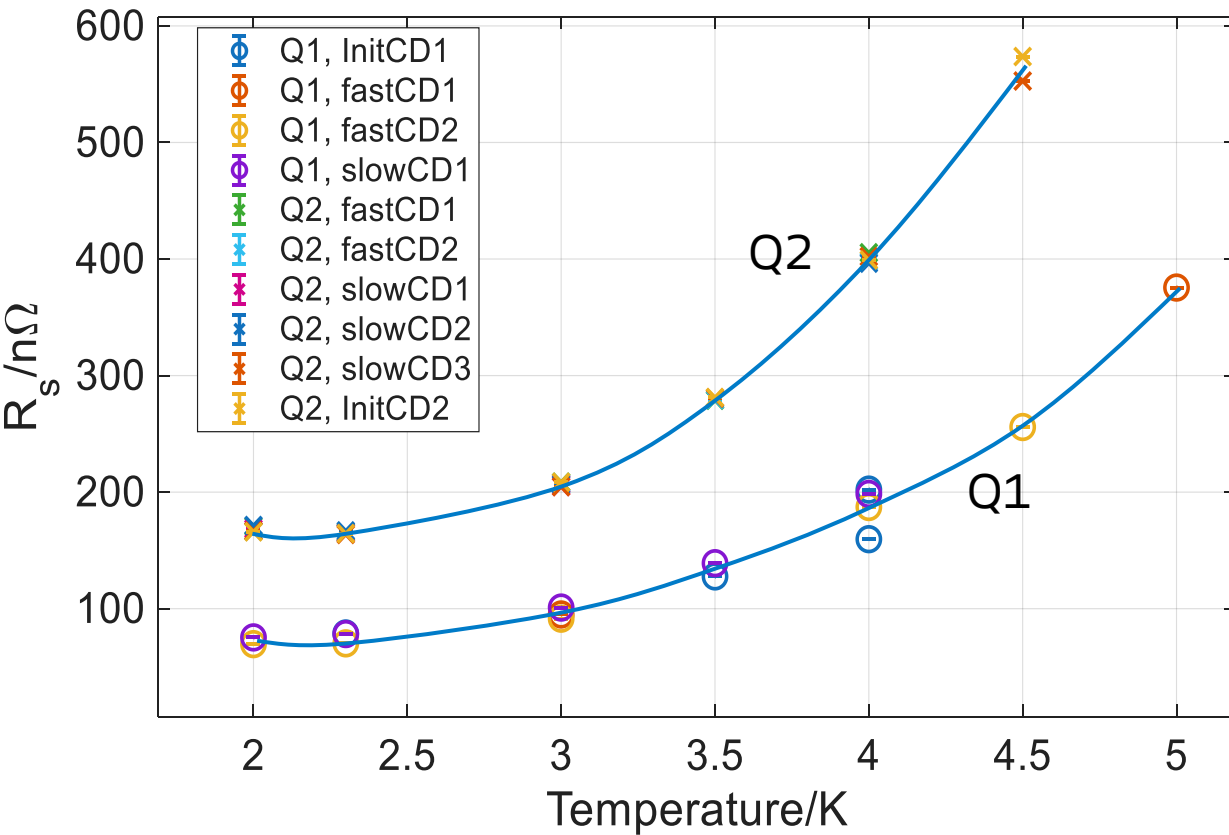

R_s @1.3GHz is way too high
→ maybe parasitic heating

Parasitic heating at 1.3GHz

- $\Delta T = T_1 - T_4$ difference between RF surface and bottom flange

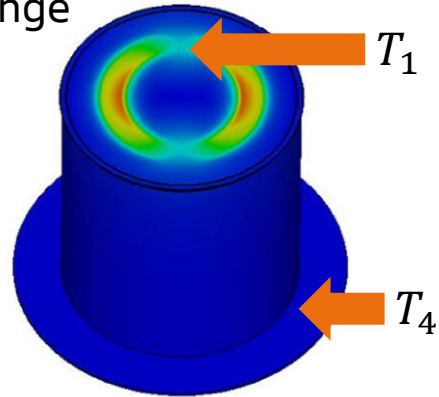

- Max B-field was limited by T_1
- ΔT shrinks with higher field, most severe at 1.3GHz

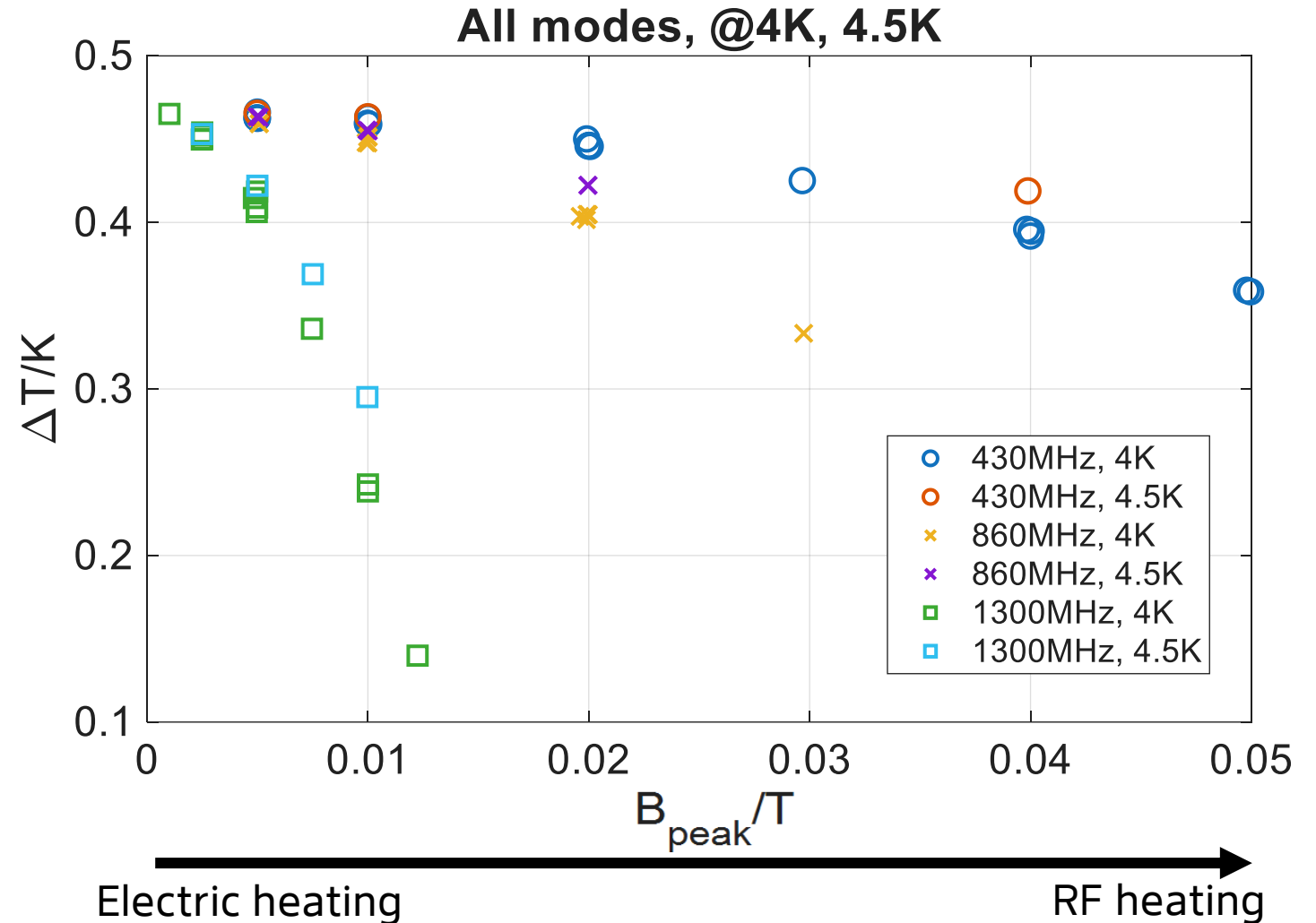

Baseline R_s vs B_{peak} - Could we see an Anti Q-slope?

- Need B-Field of 30mT and more
 - For N-doped Nb slope starts around 25mT
 - For Mid-T 1.3GHz cavities $\frac{7MV}{m} \approx 30mT$

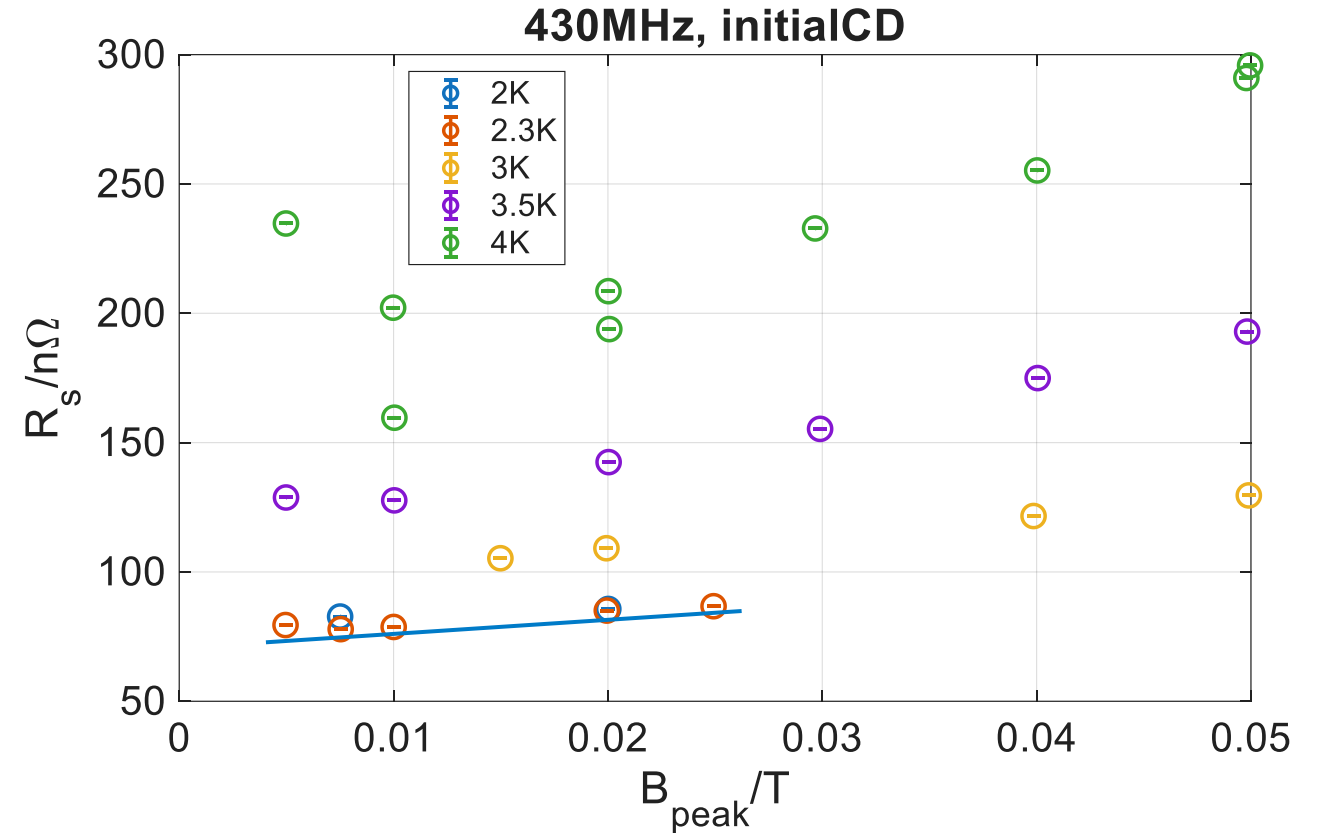

Baseline R_s vs B_{peak} - Could we see an Anti Q-slope?

- Need B-Field of 30mT and more
 - For N-doped Nb slope starts around 25mT
 - For Mid-T 1.3GHz cavities $\frac{7MV}{m} \approx 30mT$

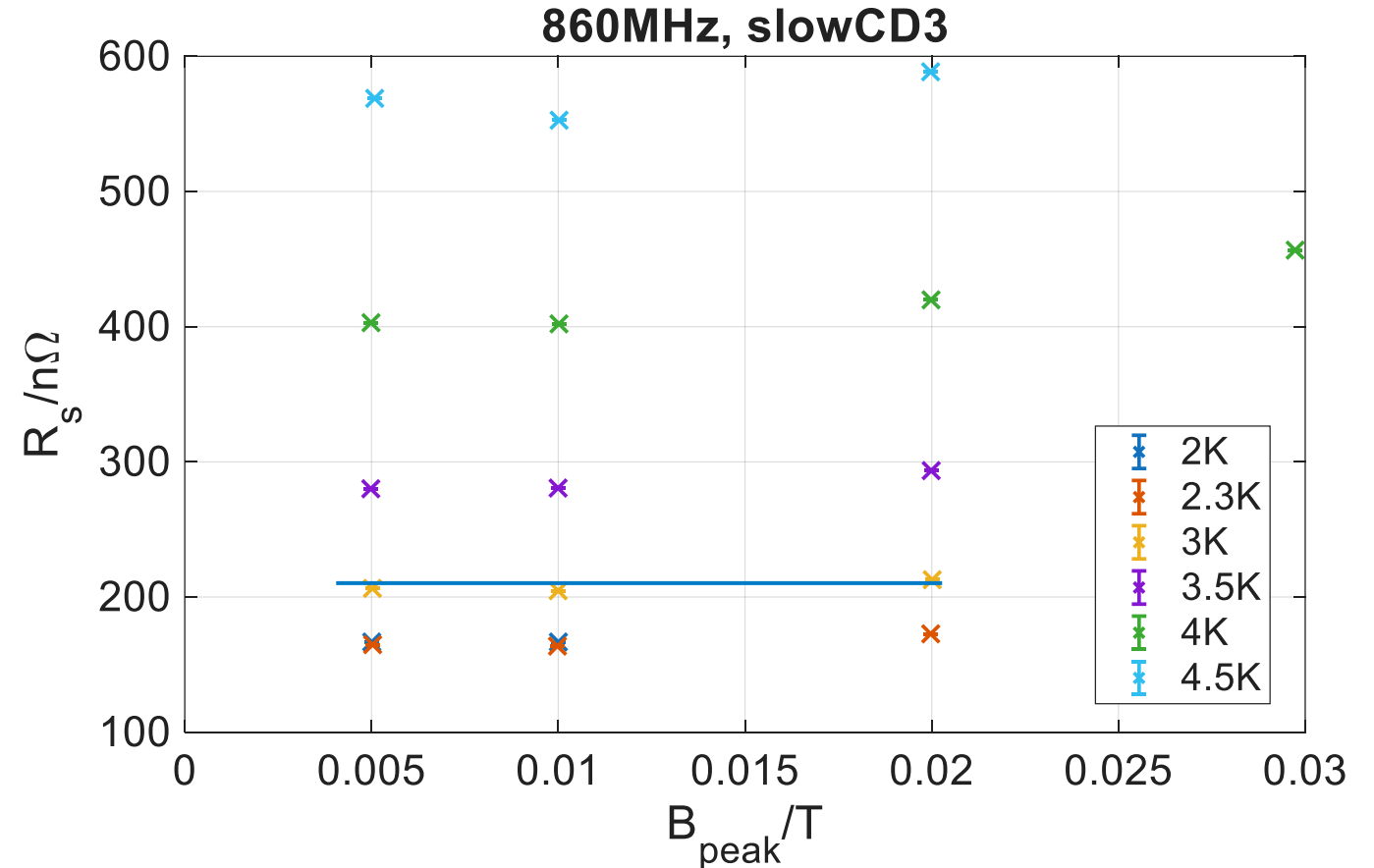

Baseline R_s vs B_{peak} - Could we see an Anti Q-slope?

- Need B-Field of 30mT and more
 - For N-doped Nb slope starts around 25mT
 - For Mid-T 1.3GHz cavities $\frac{7MV}{m} \approx 30mT$
- Problem: 1.3GHz
 - B-field is too low
 - Parasitic heating could cover up everything else
 - But: we need it, to verify the success of the Mid-T treatment

→look for the dip in f vs T

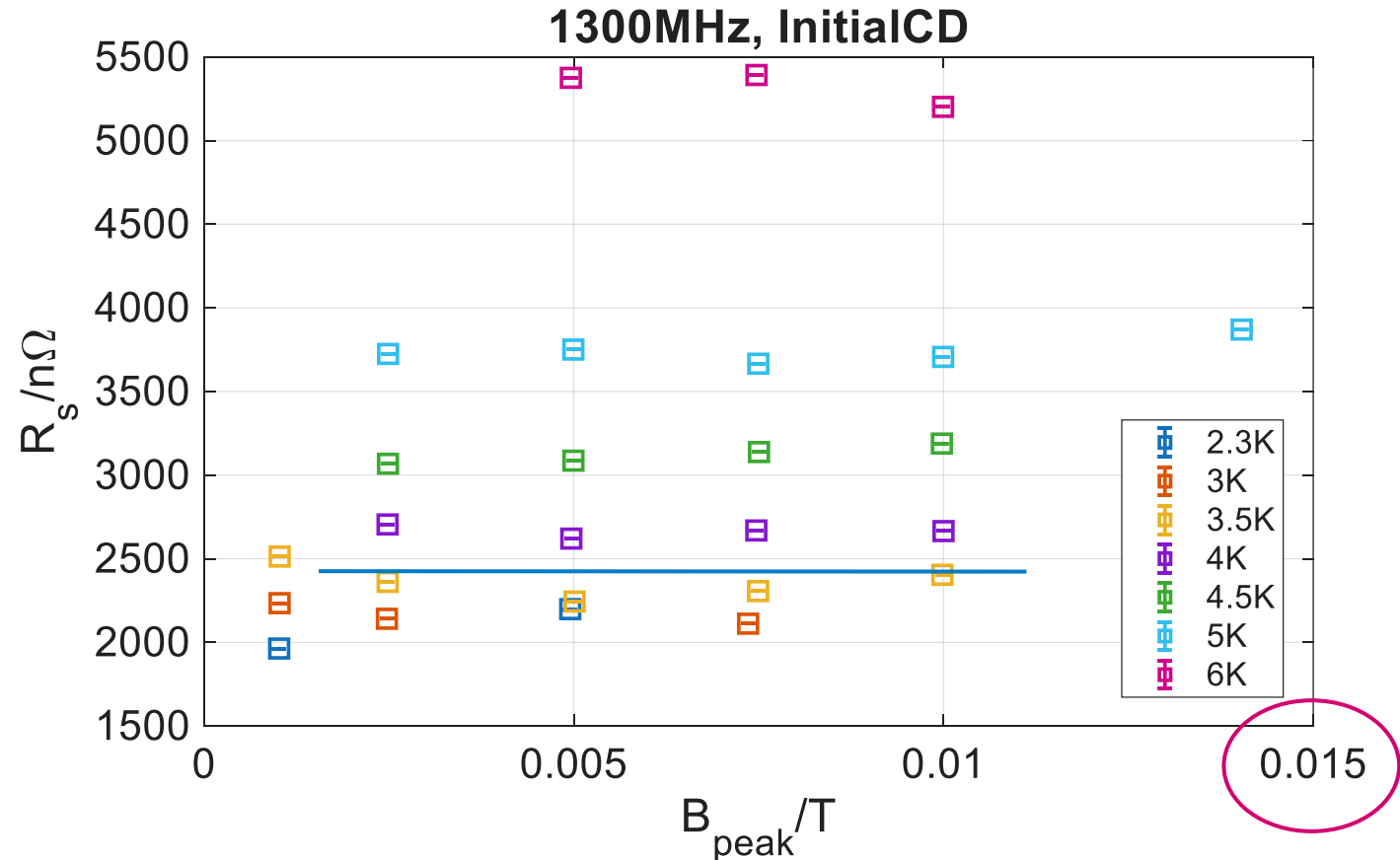

Δf vs T – shift depends on resonance frequency

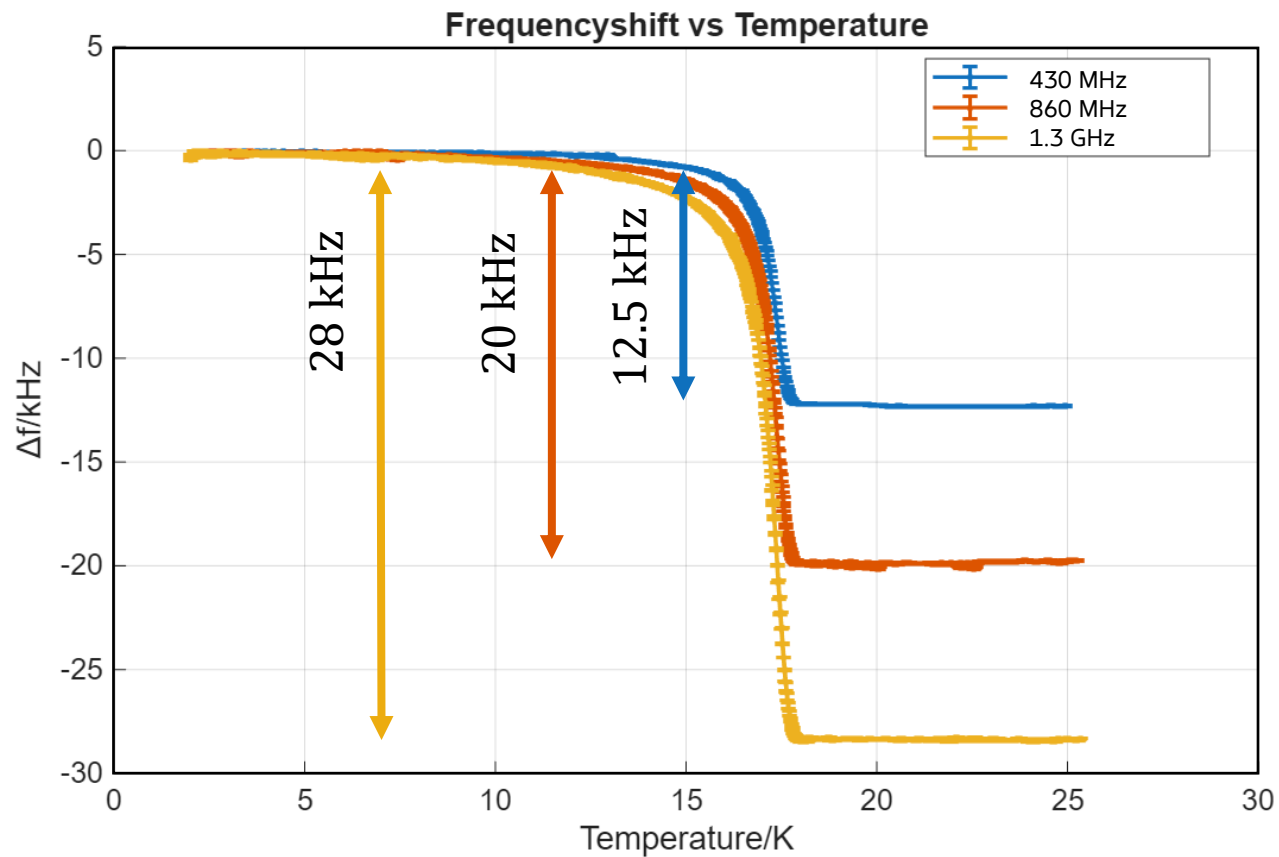

Nb₃Sn

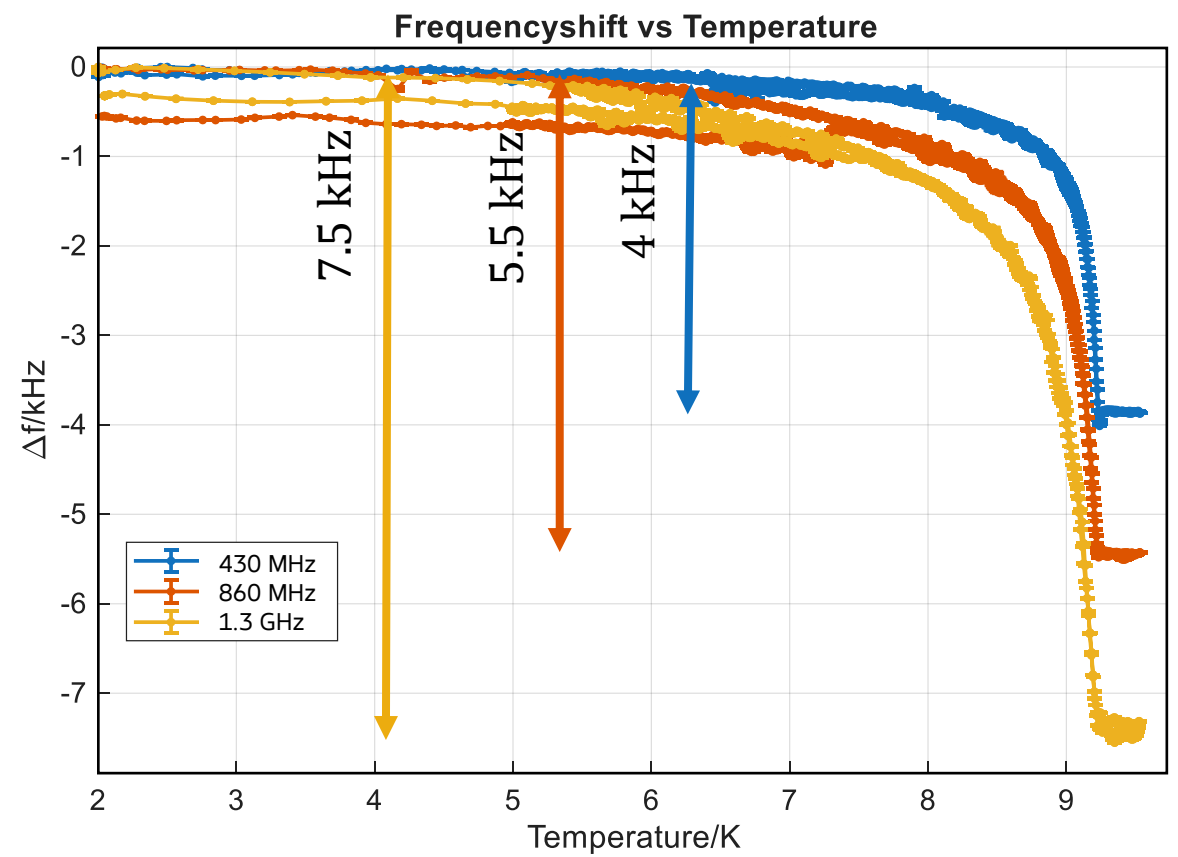

Nb-baseline

Calculate Material properties of Nb and Nb₃Sn

1. $\Delta\lambda(T) = -\frac{G}{\pi\mu_0} \frac{\Delta f(T)}{f^2}$

2. Fit with $\Delta\lambda(T) = \frac{\lambda_{eff}}{\sqrt{1-\left(\frac{T}{T_c}\right)^4}} - \lambda_{eff}$

3. With literature values for λ_L and ξ_0 calculate mean free path l

$$\lambda_{eff} = \lambda_L \sqrt{1 - \left(\frac{\pi \xi_0}{2 l}\right)^2}$$

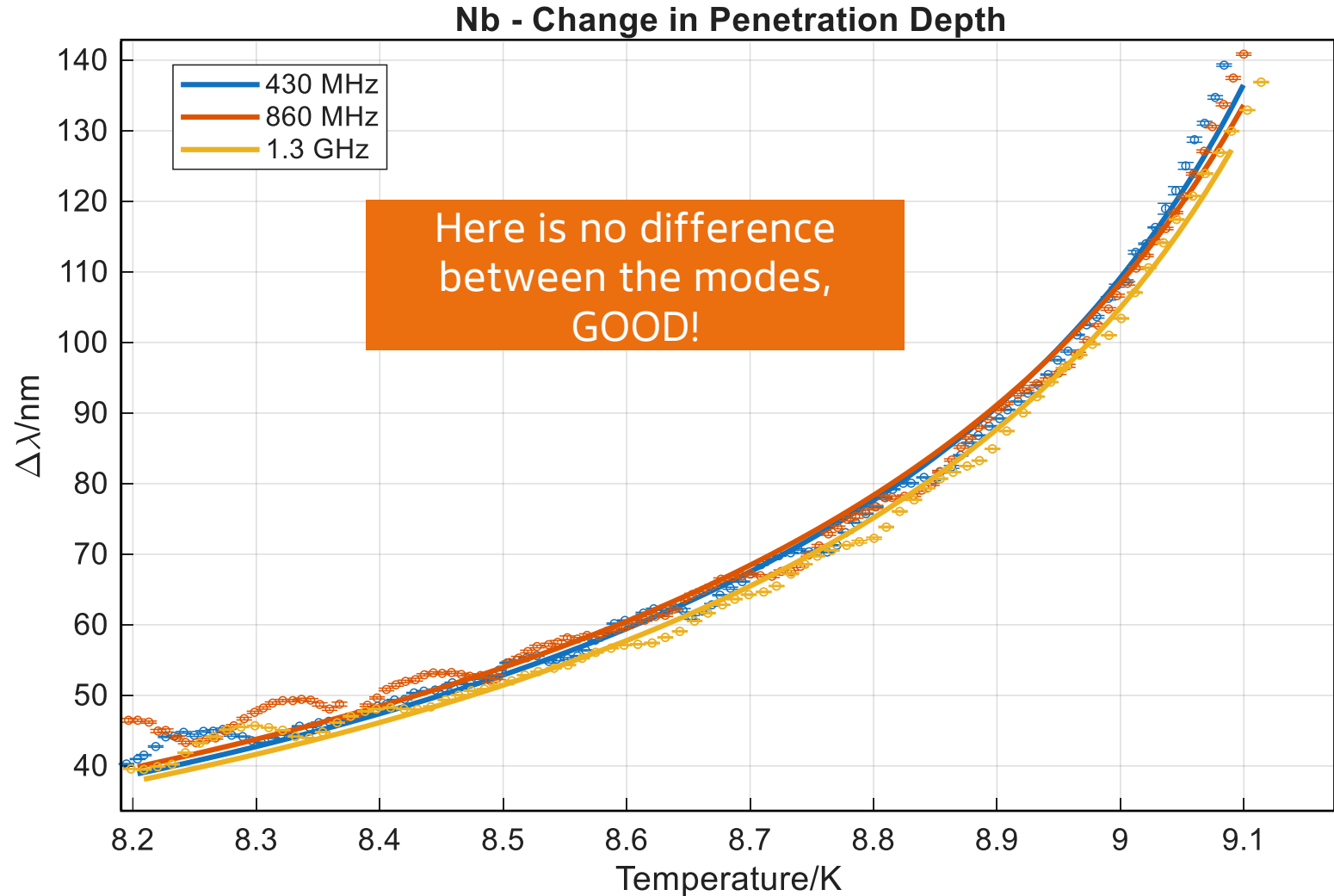

Calculate Material properties of Nb and Nb₃Sn

1. $\Delta\lambda(T) = -\frac{G}{\pi\mu_0} \frac{\Delta f(T)}{f^2}$

2. Fit with $\Delta\lambda(T) = \frac{\lambda_{eff}}{\sqrt{1-(\frac{T}{T_C})^4}} - \lambda_{eff}$

3. With literature values for λ_L and ξ_0 calculate mean free path l

$$\lambda_{eff} = \lambda_L \sqrt{1 - \left(\frac{\pi \xi_0}{2l}\right)^2}$$

→ **Nb**: $\lambda_{eff} = 72 \pm 3\text{nm}$, $T_C = 9.4 \pm 0.1\text{K}$, $l = 26 \pm 3\text{nm}$
 → $\lambda_{eff} \approx 80\text{nm}$, $T_C \approx 9.3$ [8]

→ **Nb₃Sn**: $\lambda_{eff} = 180 \pm 20\text{nm}$, $T_C = 17.3 \pm 0.2\text{K}$, $l = 2.0 \pm 0.3\text{nm}$
 → HZB: $\lambda_{eff} = 315 \pm 24\text{nm}$, $T_C = 17.60 \pm 0.03\text{K}$ [7]

Nb - Change in Penetration Depth

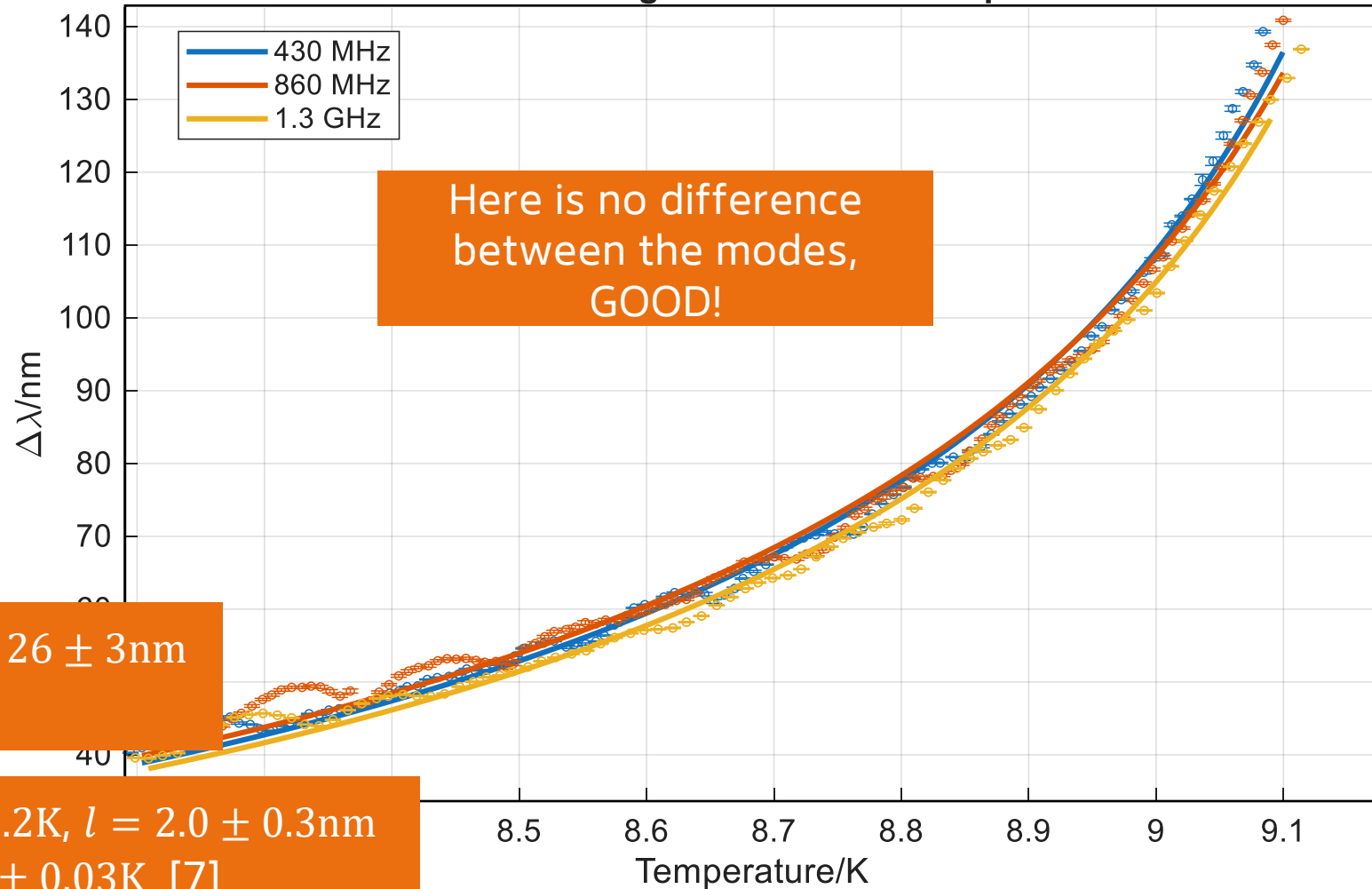

Conclusion

- UHH QPR is working well
 - Results from another QPR have been reproduced for a first time
 - R_s and $f(T)$ measurements deliver reasonable values
- Outlook
 - Technical improvements
 - Mid-T measurement
 - Threshold frequency?
 - General behavior at lower frequency?

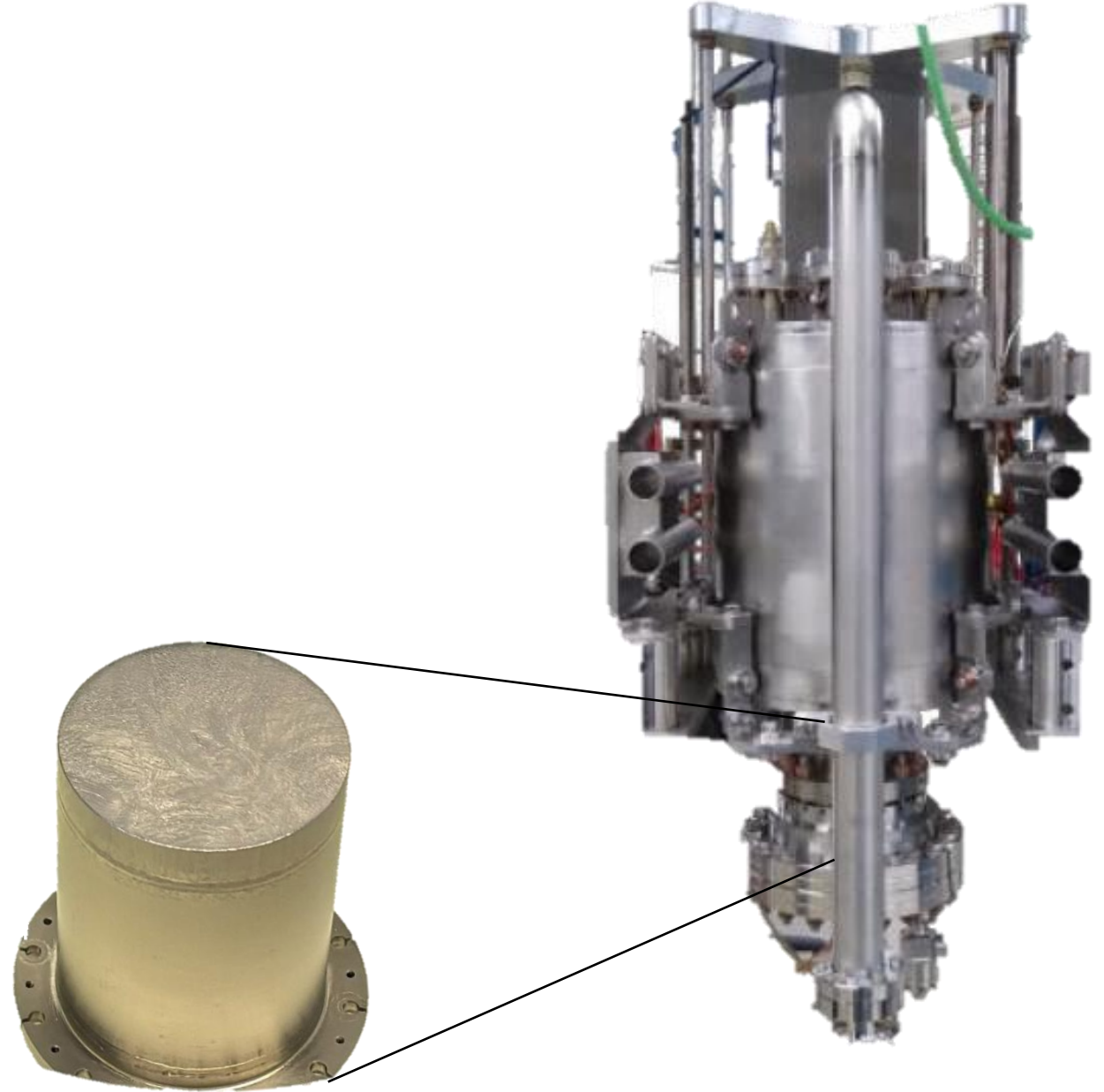

References

- [1] Villa, Ricardo Monroy. Development of a test resonator for investigations of the RF properties of superconducting materials. Universitaet Hamburg (Germany), 2023.
- [2] T. Junginger. Investigations of the surface resistance of superconducting materials. Ph.D. thesis, Ruprecht-Karls- Universität, Heidelberg, Germany, 2012.
- [3] Bate, C., K. Kasprzak, D. Reschke, u. a. „Correlation of Srf Performance to Oxygen Diffusion Length of Medium Temperature Heat Treated Cavities*“ . *Superconductor Science and Technology* 38, Nr. 2 (2025): 025003. <https://doi.org/10.1088/1361-6668/ad9fe8>.
- [4] Martinello, Martina, et al. Anti-Q-slope enhancement in high-frequency niobium cavities. No. FERMILAB-CONF-18-611-TD. Fermi National Accelerator Lab.(FNAL), Batavia, IL (United States), 2018.
- [5] Lebedeva, Anastasiya, Matúš Hladký, Marcel Polák, und František Herman. „Local Limit Disorder Characteristics of Superconducting Radio Frequency Cavities“ . *Physical Review Applied* 24, Nr. 4 (2025): 044007. <https://doi.org/10.1103/5hp2-3x8n>.
- [6] M. Becks et al. “Superconducting Cavities and their Applications – Recent Work at the University of Wuppertal“ . In: Proc. of the 4th Workshop on RF Superconductivity (SRF'89), KEK, Tsukuba, Japan. 1989, pp. 109–138. url: <http://accelconf.web.cern.ch/AccelConf/SRF89/papers/srf89b01.pdf>.
- [7] D. Fonnesu, D. Ford, E. Chyhyrynets, u. a. „Recipe Optimization and SRF Test of Cu-Compatible Nb₃Sn Films by DC Magnetron Sputtering from a Stoichiometric Target“ . *Scientific Reports* 16, Nr. 1 (2026): 3539. <https://doi.org/10.1038/s41598-025-33547-w>.
- [8] Gubin, A. I., K. S. Il'in, S. A. Vitusevich, M. Siegel, und N. Klein. „Dependence of Magnetic Penetration Depth on the Thickness of Superconducting Nb Thin Films“ . *Physical Review B* 72, Nr. 6 (2005): 064503. <https://doi.org/10.1103/PhysRevB.72.064503>

Backups

Fundamentals

- Superconducting cavities are 1000 times more efficient
- Characteristic curve $Q_0(E_{acc})$
 - $Q_0 = \frac{\omega U}{P_C} \propto \frac{1}{R_s}$... quality factor
 - $E_{acc} \propto B_{peak}$... acceleration
- Investigation of new treatments and materials

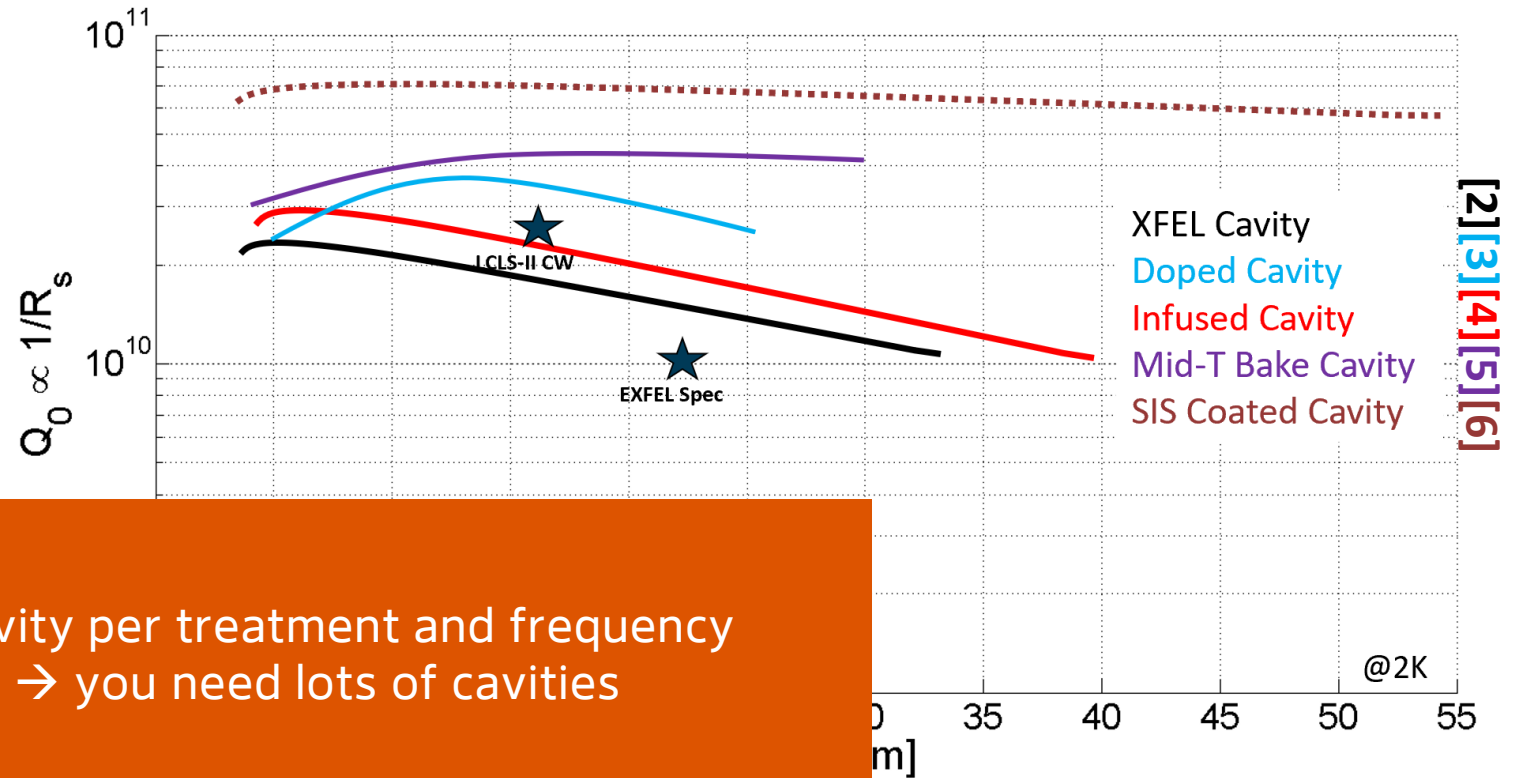

1 cavity per treatment and frequency
 → you need lots of cavities



High Q_0 = low losses

High E_{acc} = more acceleration

[1]

Nb - Temperatures @1300MHz

„parasitic heating?“

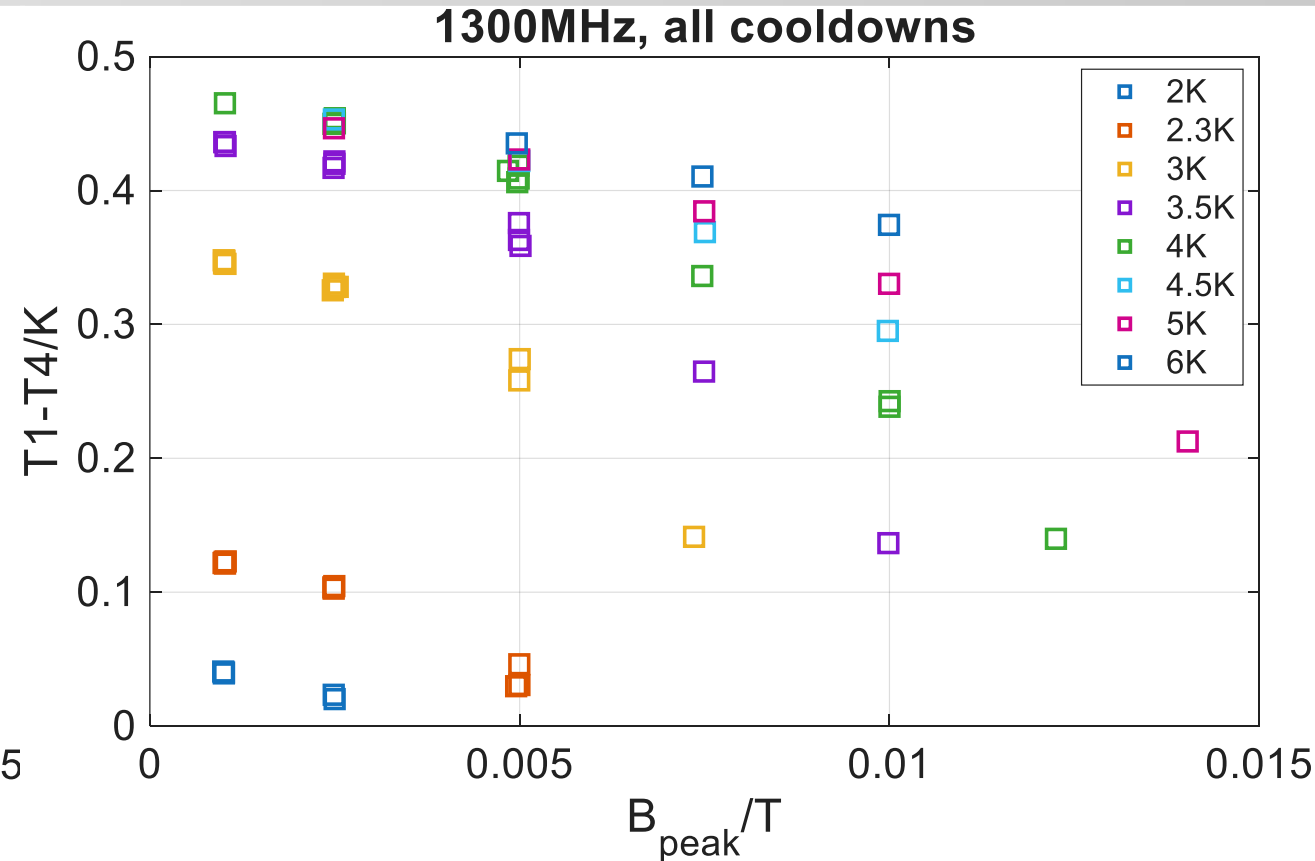
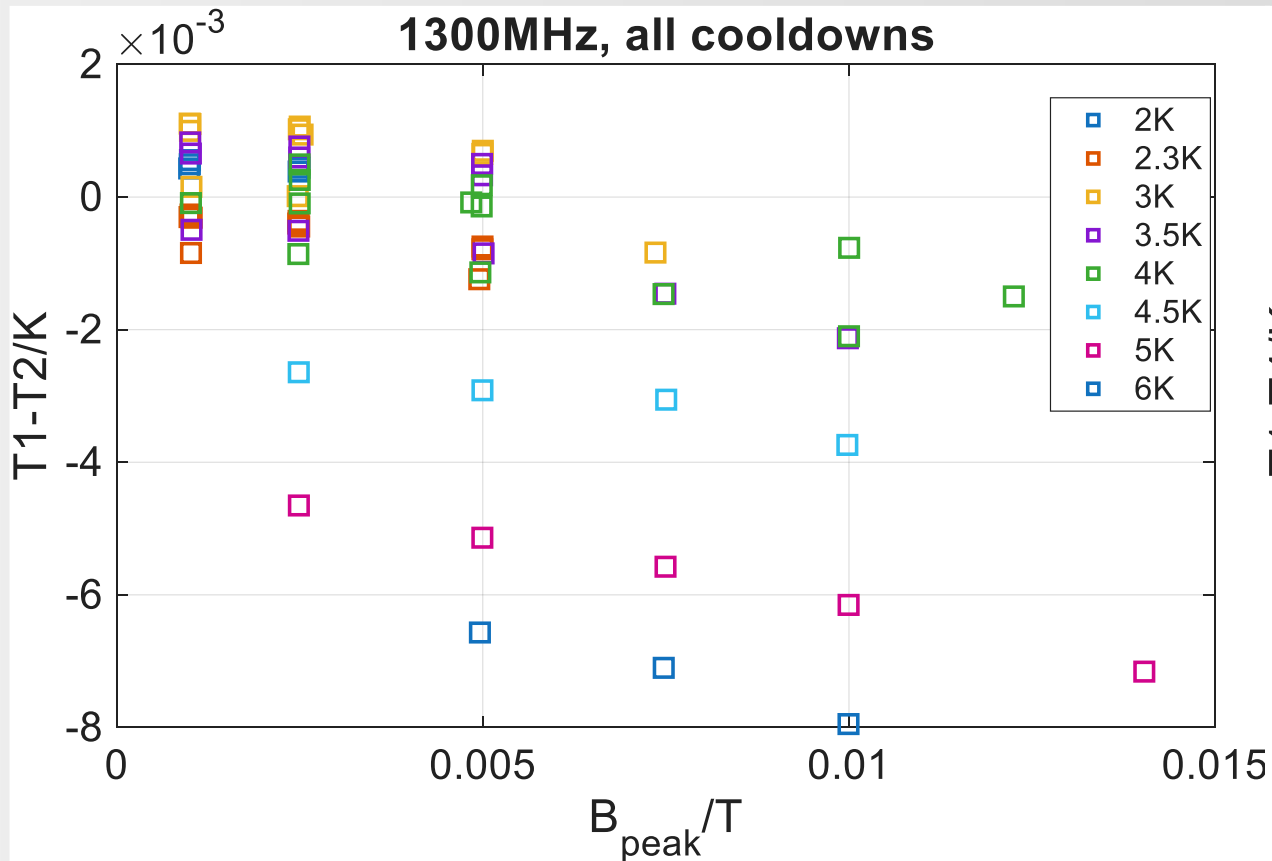

Nb - Temperatures @430MHz „normal behavior“

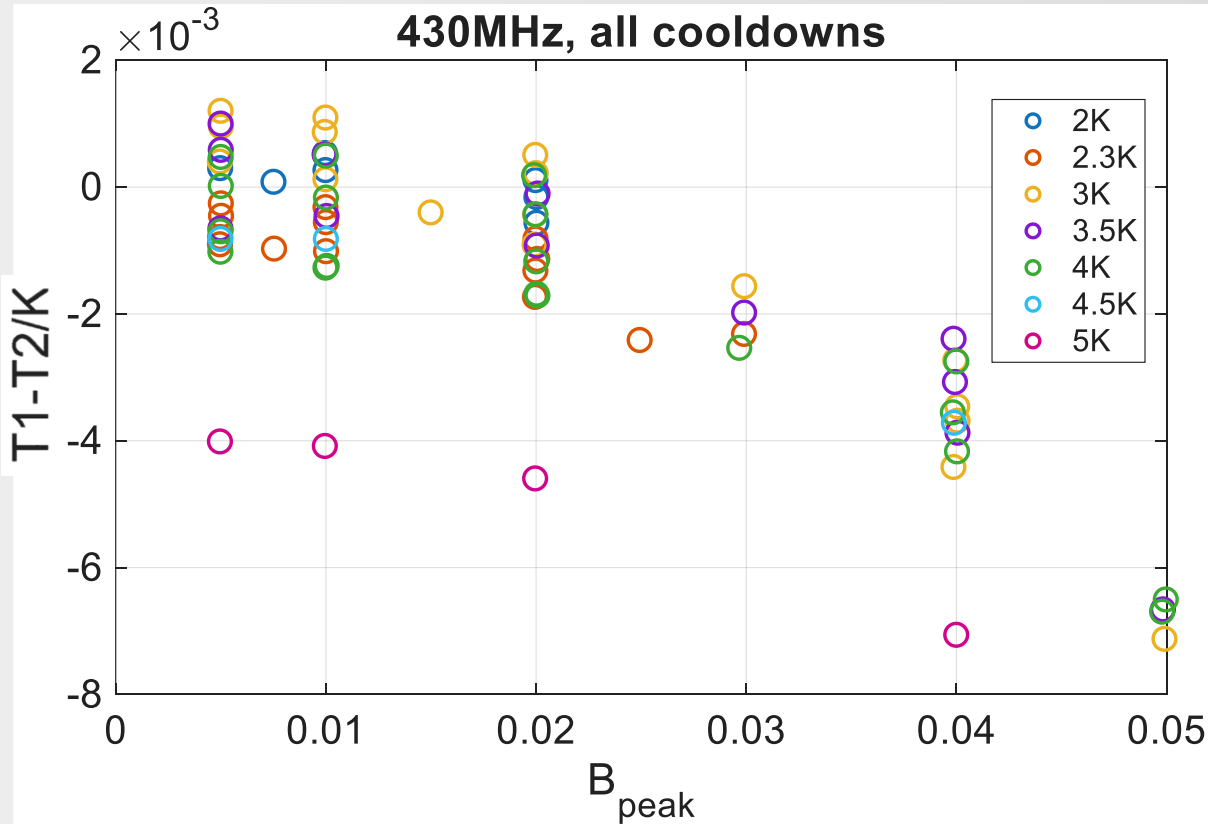

field, because one of the sensors is under a poleshoe
very small difference

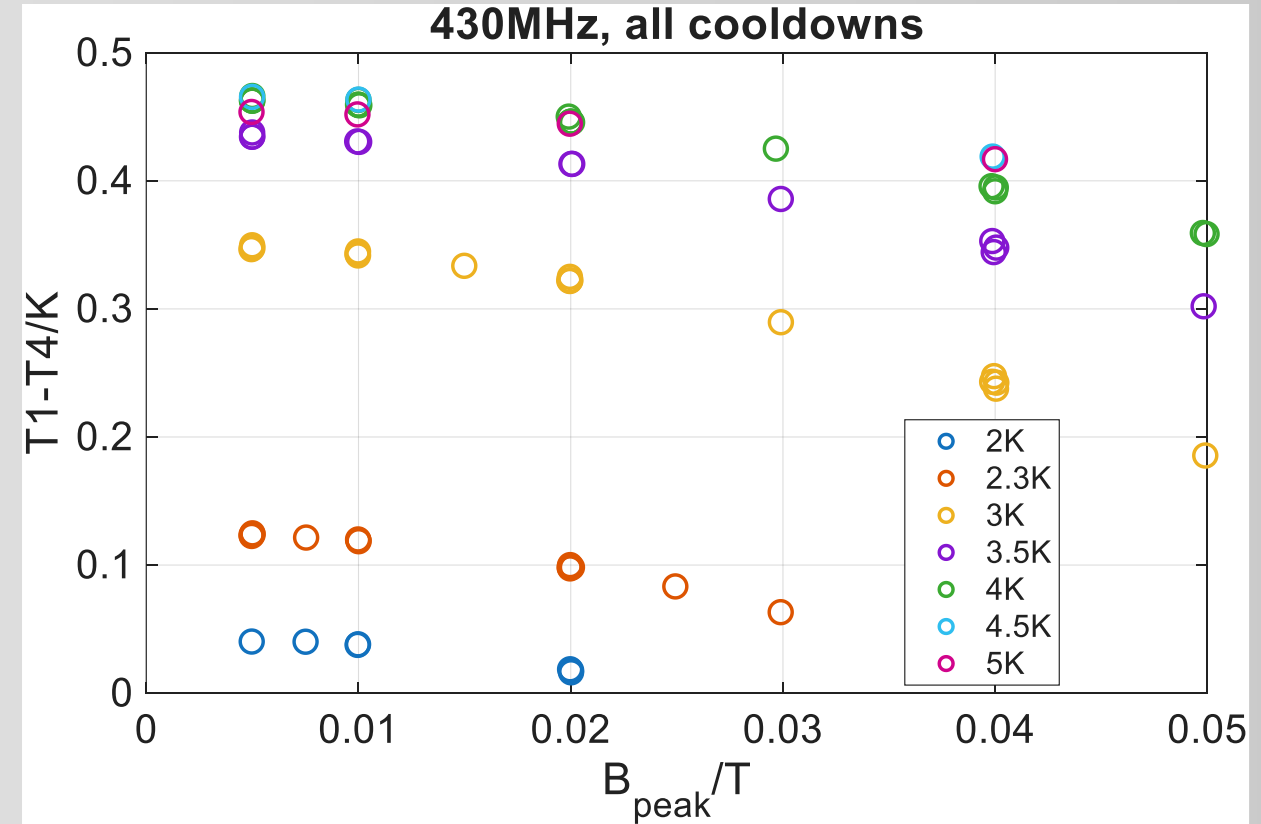

Difference changes only slightly

Why "Quadrupole"?

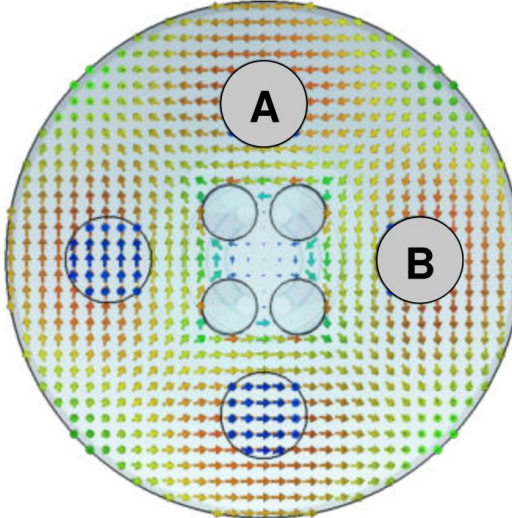
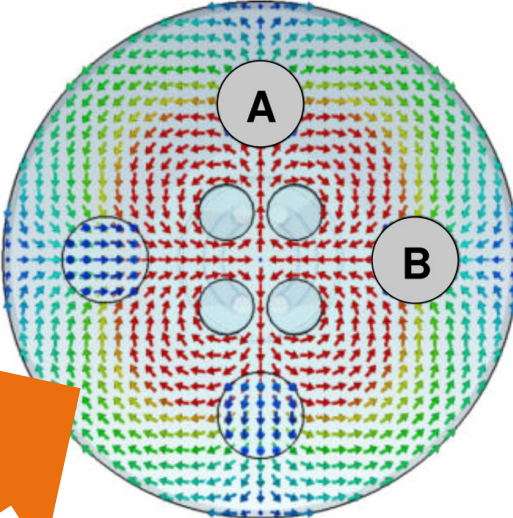
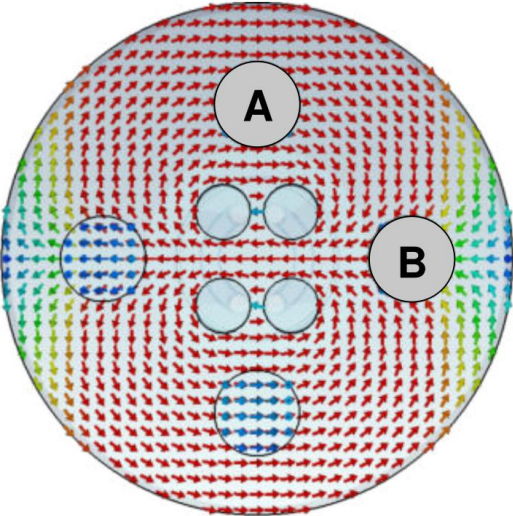
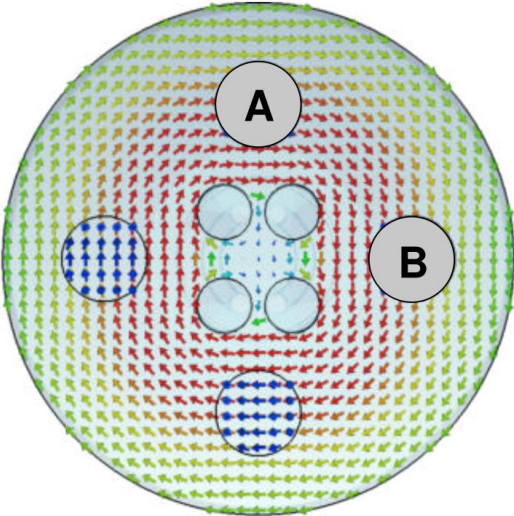
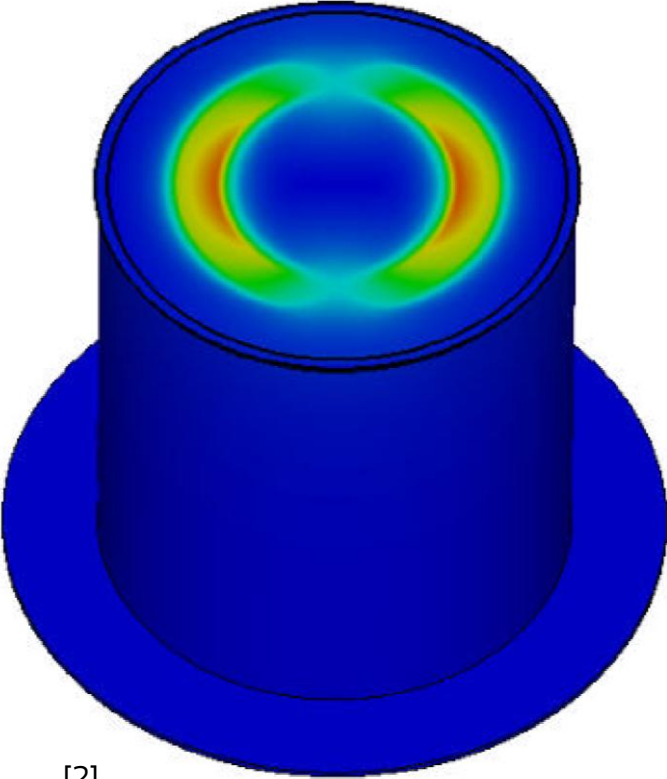

Research questions I will address

- How does a sample behave after mid-T treatment for different frequencies?
 - Anti-Q-slope for all frequencies?
- How does the local minimum in $f\nu T$ look like for different frequencies?
 - Relevant for theoretical modeling
- How does a sample behave after mid-T / low-T treatment for different frequencies?

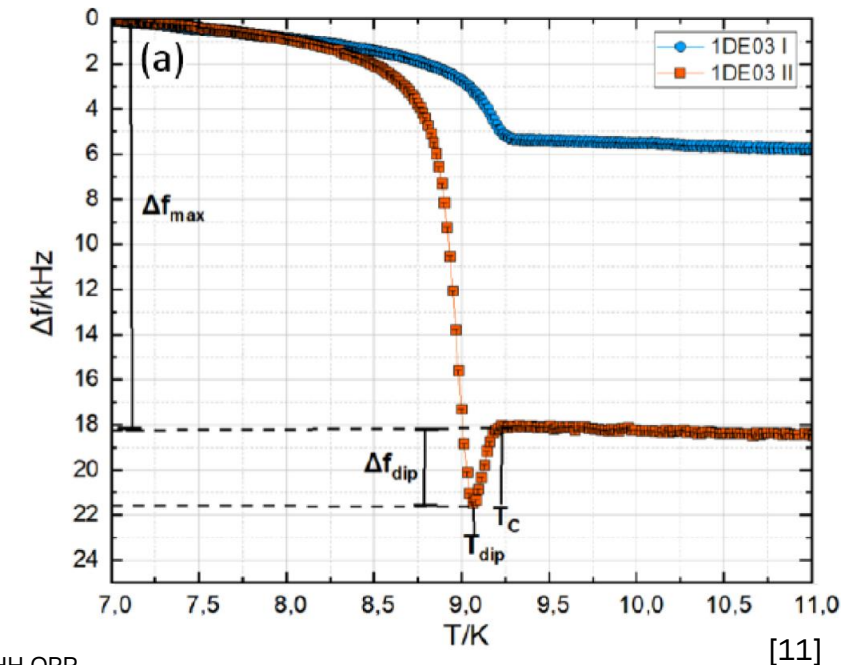
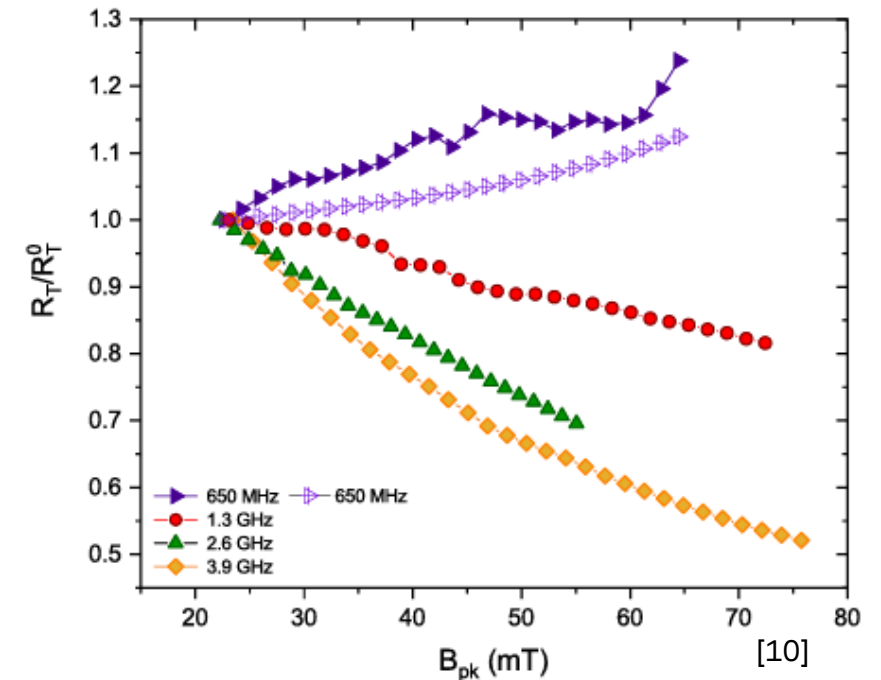

Nb R_s - Shift between modes is too high

- $R_{s,Q1} = 70 \dots 80 \text{ n}\Omega$ @430MHz, 2.3K
- $R_{s,Q2} = 165 \dots 175 \text{ n}\Omega$ @860MHz, 2.3K
- $R_{s,Q3} = 2000 \dots 2200 \text{ n}\Omega$ @1290MHz, 2.3K
- For Nb theory :
 - $R_{BCS} \sim \left(\frac{f}{1.5}\right)^2$
 - $R_{res} \sim f^{1.8}$
 - $\rightarrow R_{s,Q2} \approx 1.8 \cdot R_{s,Q1}$
 - $\rightarrow R_{s,Q3} \approx 4 \cdot R_{s,Q1}$
- Could come from parasitic heating
 - Less cut-off in coaxial gap for higher frequency

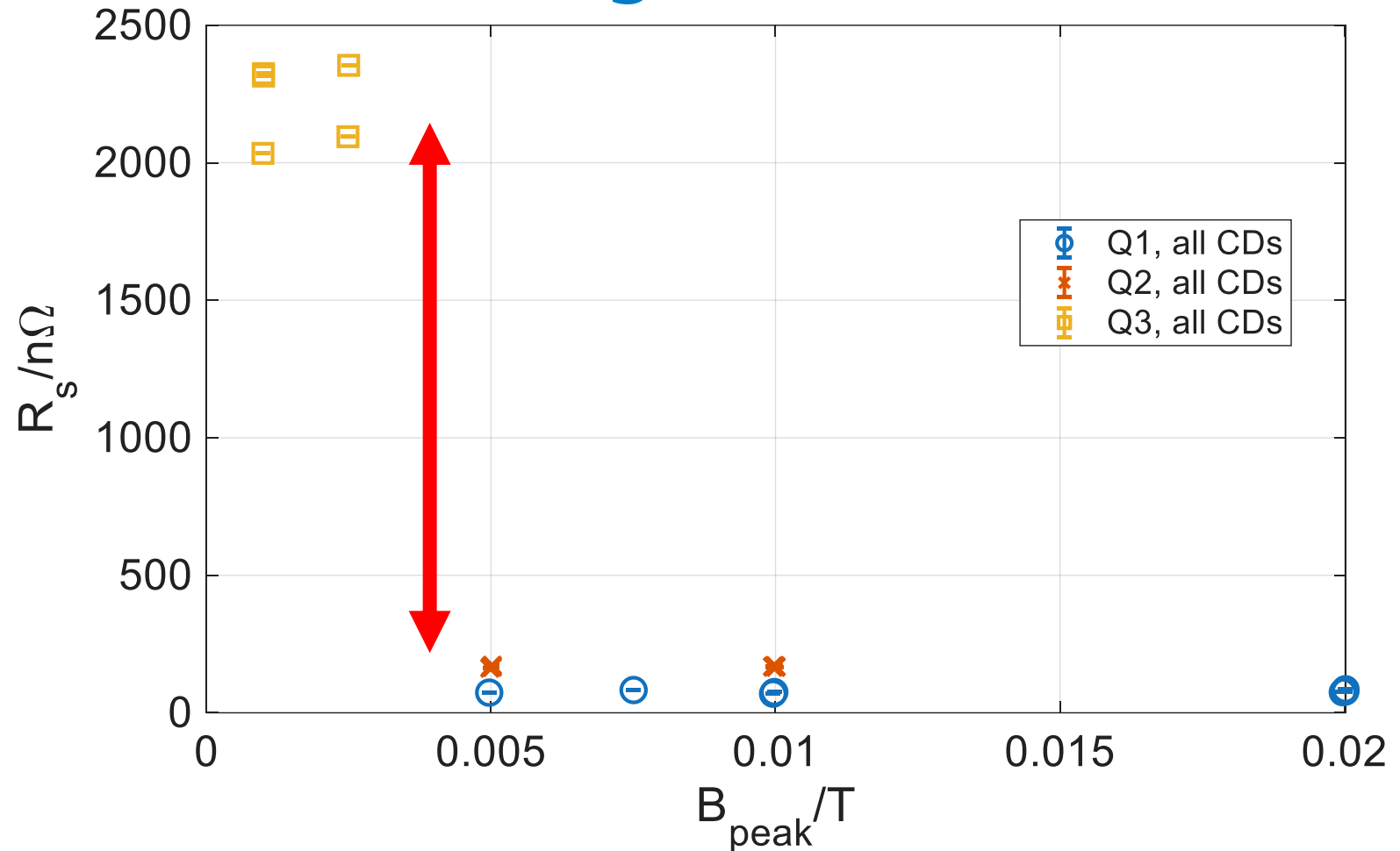

NBE06-baseline: All cooldowns @2.3K

RF traces

- Resulting traces when RF power is cut off
- Majority of energy U flows out through input antenna P_{ref}
- $U = \int_0^{\infty} P_{ref} dt$
- $B_{peak} = \sqrt{c_2 U}$
 - With c_2 geometrical constant from simulation
- $Q_{loaded} = 2\pi\tau_{ref}f$
 - With τ being the decay time

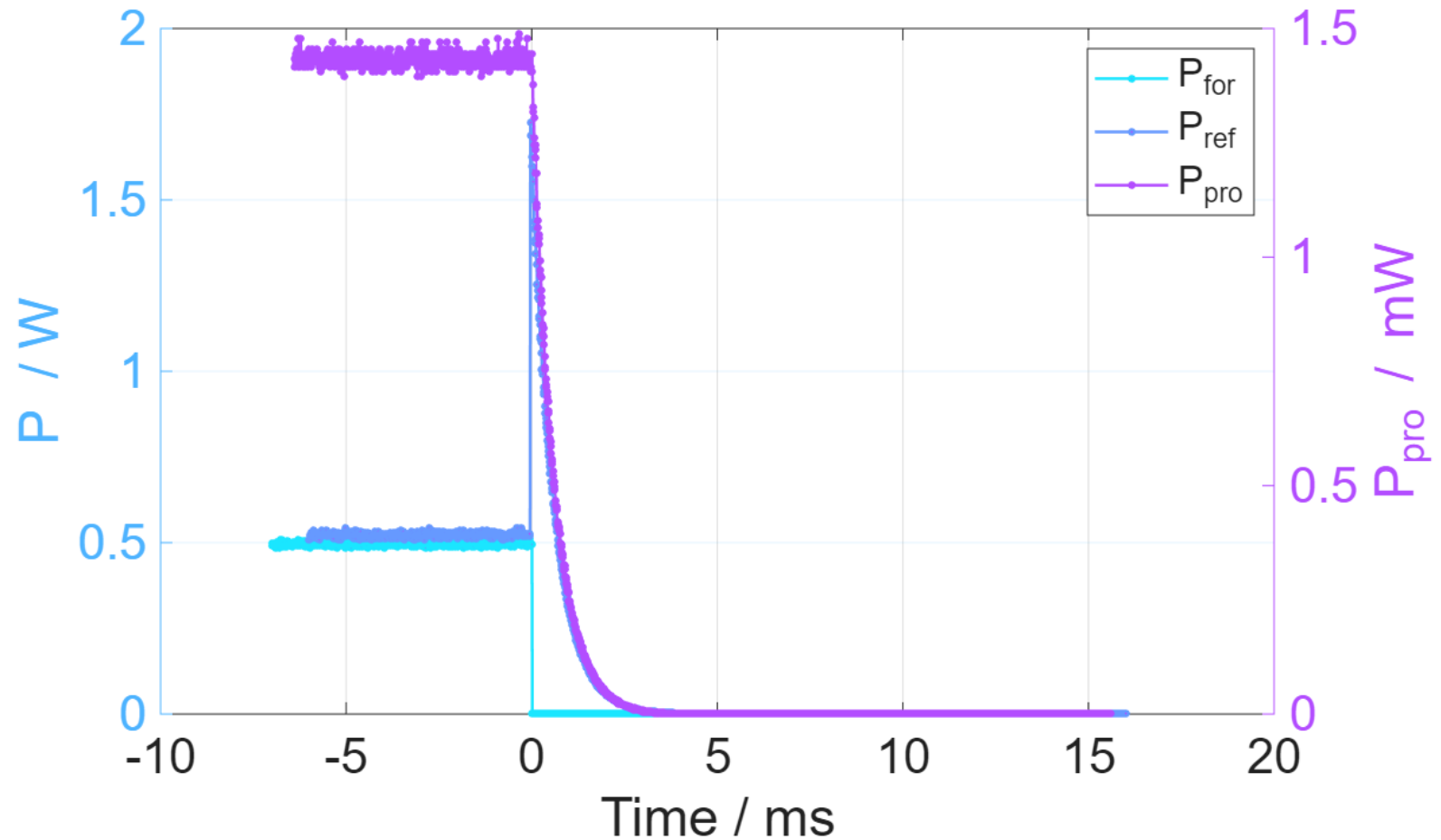

All Rs vs T of Nb3Sn

$$\text{Fit with: } R_s(T) = A \frac{f^2}{T} \exp\left(-\frac{\Delta(0)}{k_B T}\right) + R_{Res}$$

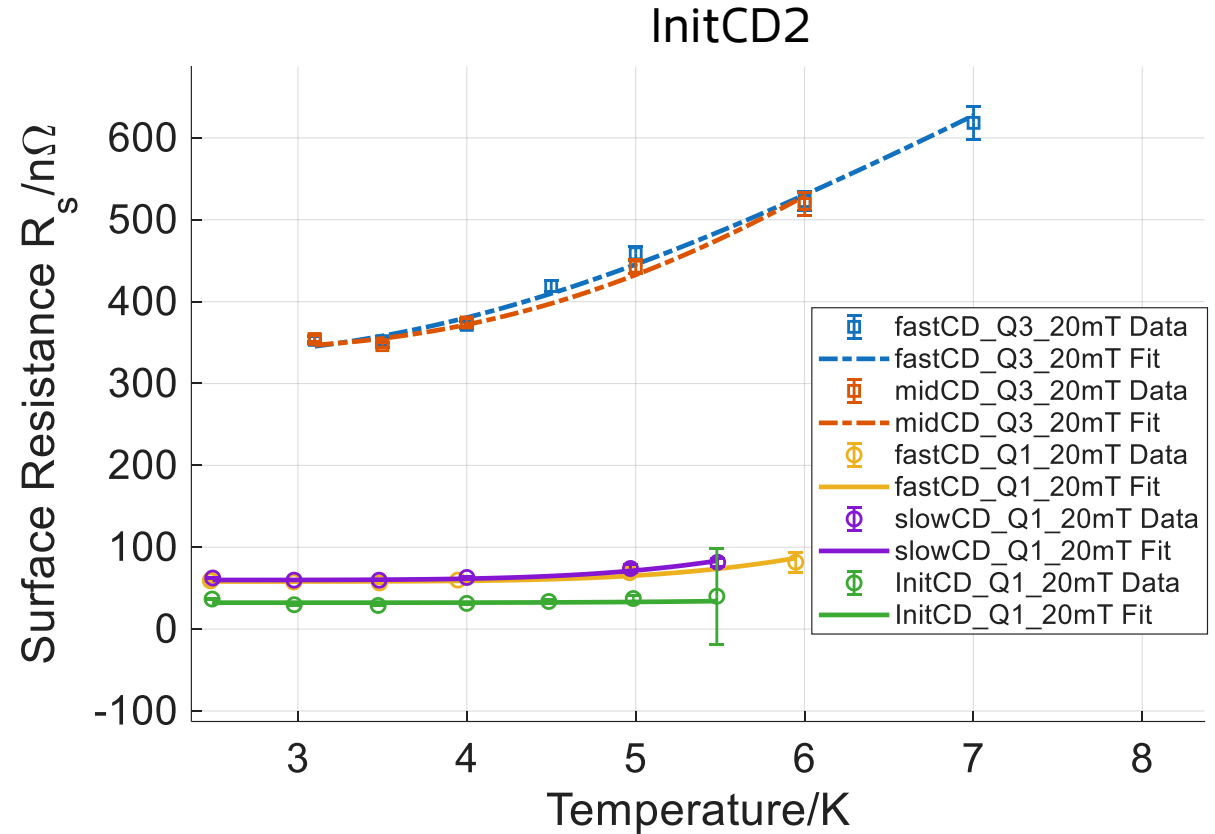
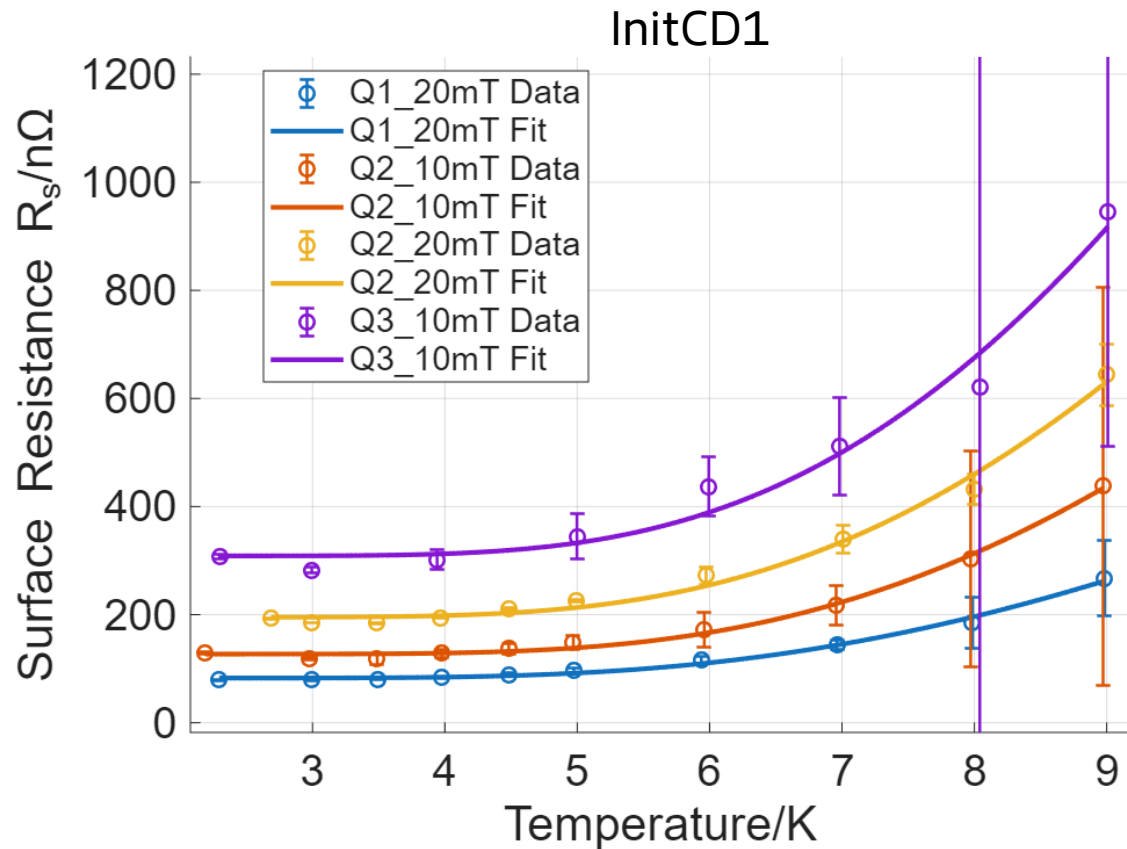

run	initCD1	initCD2	Slow	fast
R_{res}	$79 \pm 2n\Omega$	$32 \pm 6n\Omega$	$60 \pm 2n\Omega$	$58 \pm 2n\Omega$
Energy gap Δ	—	—	$4 \pm 8meV$	$3 \pm 5meV$

R_{BCS} Nb3Sn

- R_{BCS} is small and equal within the uncertainty
- The sensitivity to cooldowns lies in R_{res} \rightarrow flux trapping
- R_S should be minimal at lowest temperature, but is not always
- Probably some leftover heat in the system from earlier test

